



(12) **UK Patent** (19) **GB** (11) **2 347 952** (13) **B**

(45) Date of publication: **08.10.2003**

(54) Title of the invention: **Apparatus for coupling a tubular member to a pre-existing structure**

(51) Int Cl⁷: **E21B 43/10 33/14**

(21) Application No: **0004285.3**

(22) Date of Filing: **23.02.2000**

(30) Priority Data:
(31) **60121841** (32) **26.02.1999** (33) **US**
(31) **60154047** (32) **16.09.1999** (33) **US**

(60) Parent of Application No(s)
0310797.6, 0310795.0, 0310770.3, 0310785.1,
0310759.6, 0310801.6, 0310799.2, 0310772.9,
0310757.0, 0310833.9, 0310836.2 under
Section 15(4) of the Patents Act 1977

(43) Date A Publication: **20.09.2000**

(52) UK CL (Edition V):
E1F FJT FLA

(56) Documents Cited:
GB 2348657 A **GB 2347950 A**
GB 2344606 A **GB 2243191 A**
GB 1111536 A **GB 0961750 A**
GB 0557823 A **EP 0881354 A**
WO 1999/035368 A **WO 1999/006670 A**
WO 1998/000626 A **US 6070671 A**

(58) Field of Search:
As for published application 2347952 A viz:
UK CL (Edition R) **E1F FJT FLA**
INT CL⁷ **E21B**
Other: **Online: WPI,EPODOC,JAPIO**
updated as appropriate

Additional Fields
UK CL (Edition S) **F1P**

(72) Inventor(s):
Robert Lance Cook
David Paul Brisco
Lev Ring
Michael L Bullock

(73) Proprietor(s):
Shell Internationale Research
Maatschappij B.V.
(Incorporated in the Netherlands)
Department IP/43 Carel Van Bylandtlaan
30, 2596 HR The Hague, Netherlands

(74) Agent and/or Address for Service:
Haseltine Lake & Co
Imperial House, 15-19 Kingsway,
LONDON, WC2B 6UD, United Kingdom

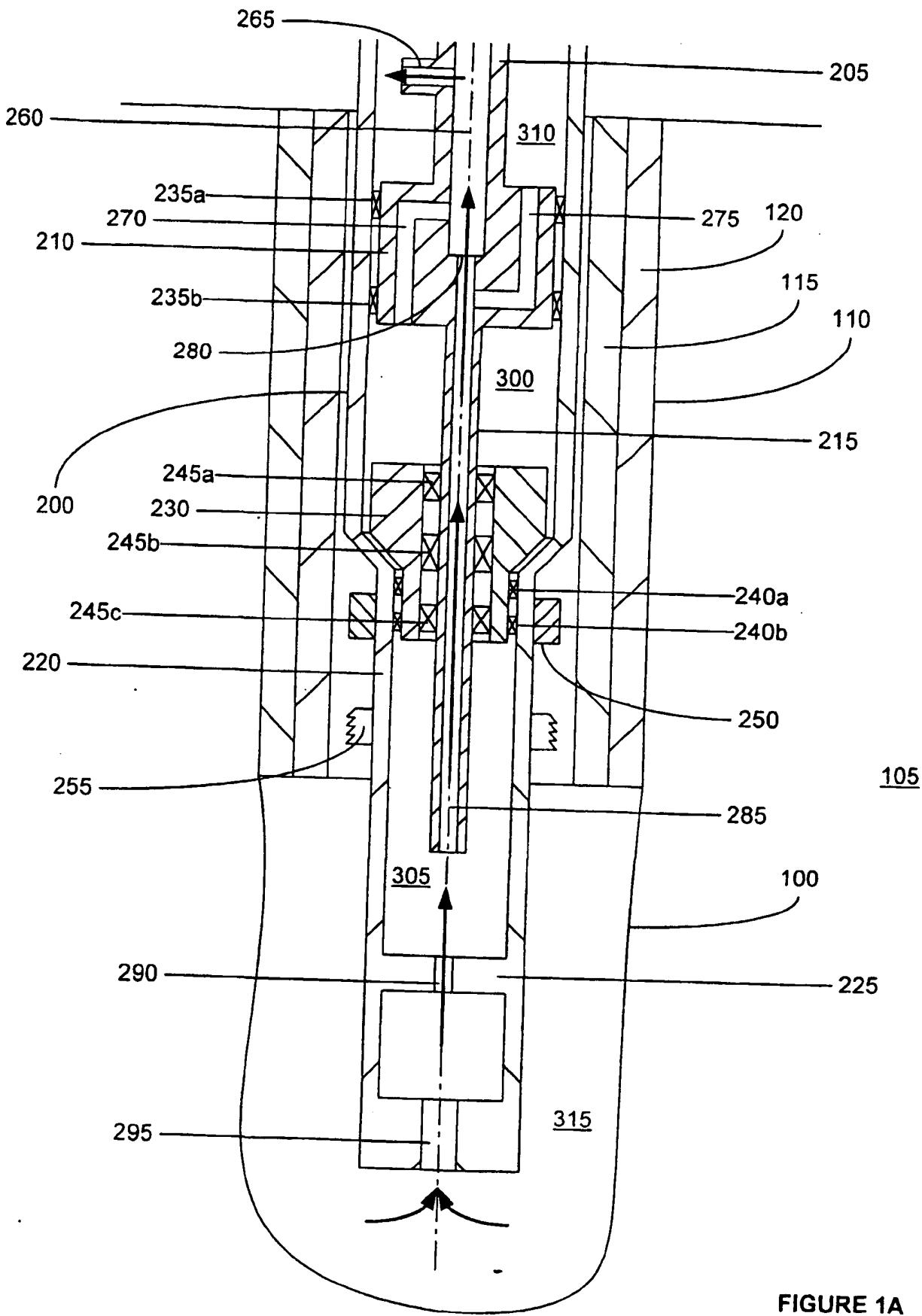

FIGURE 1A

279

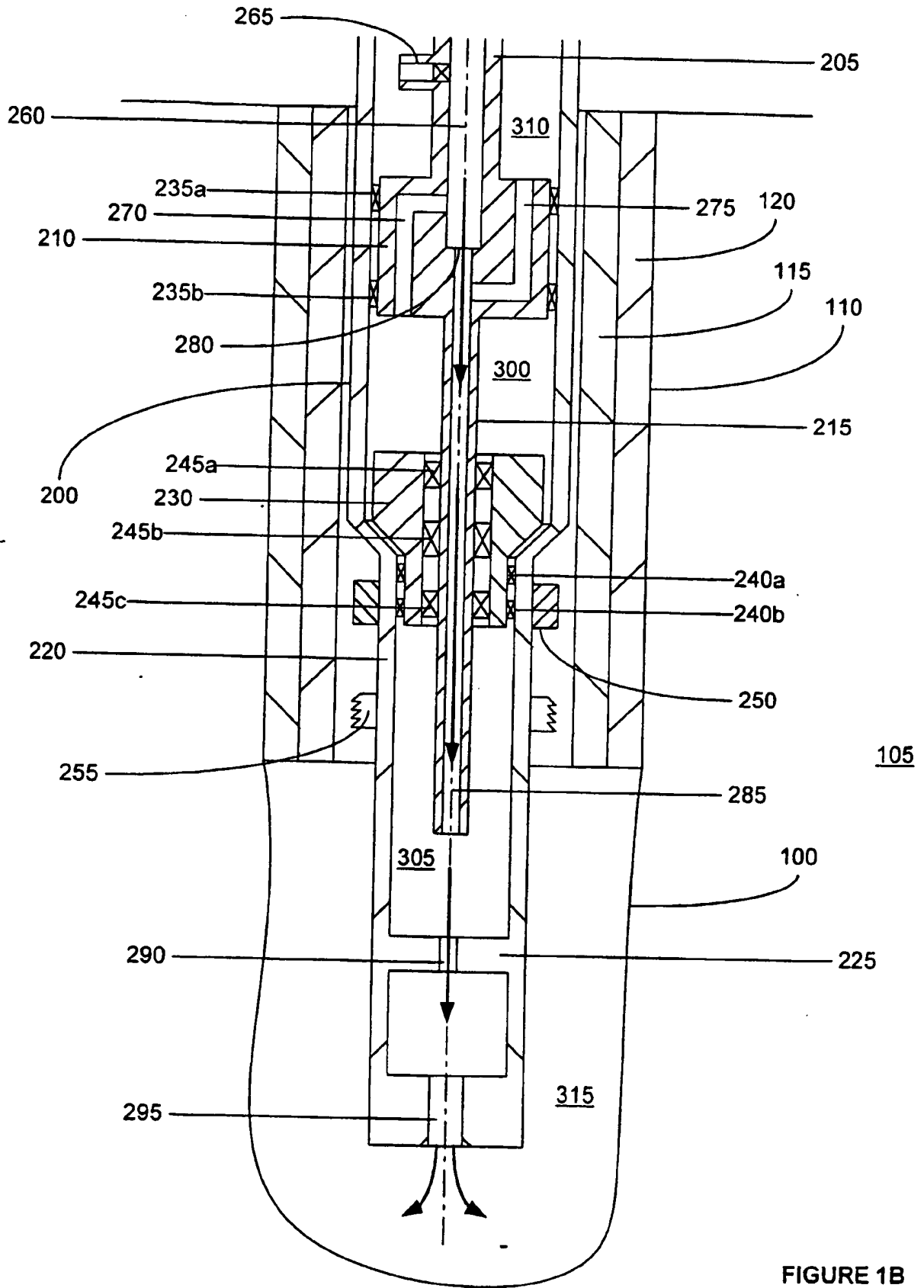

FIGURE 1B

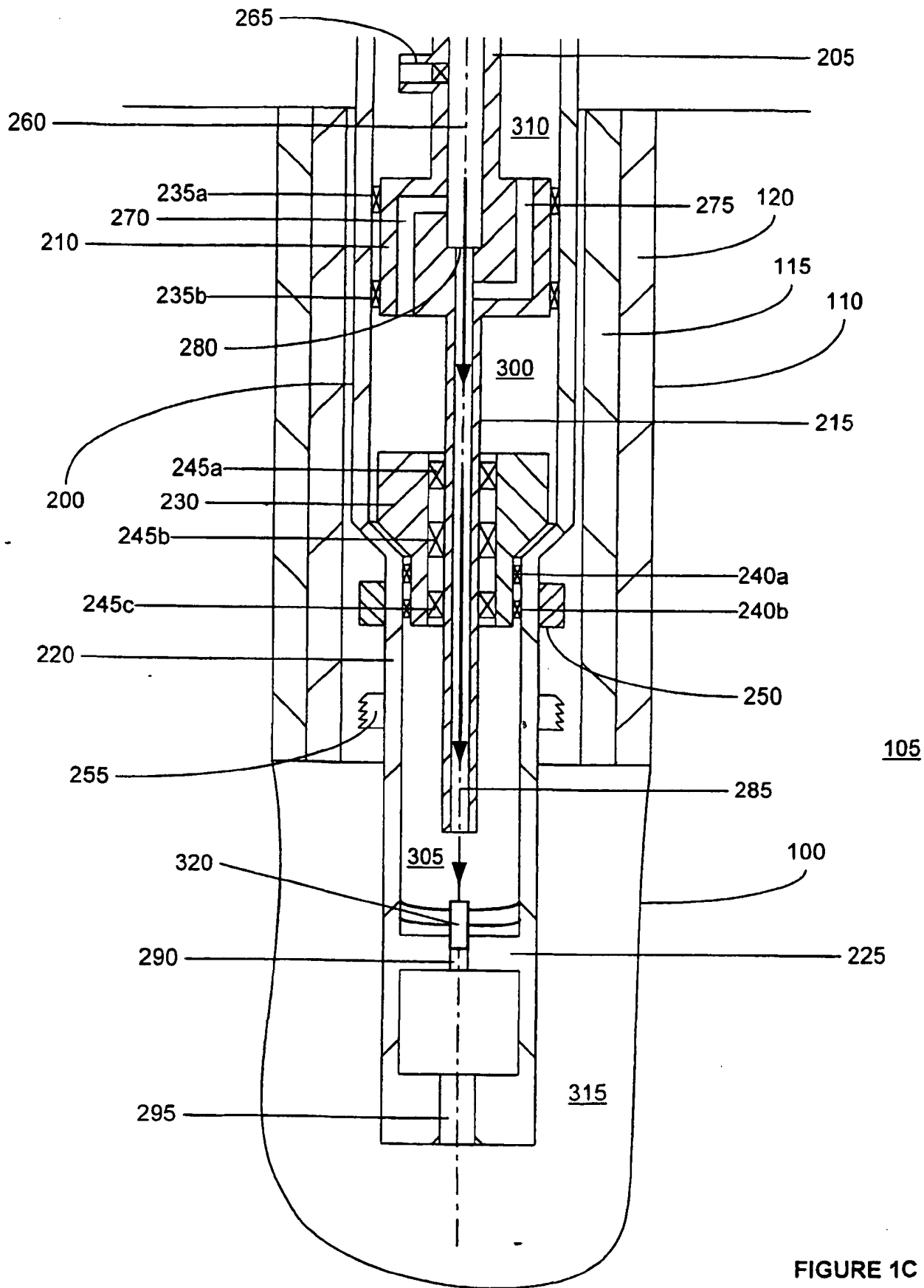

FIGURE 1C

4/79

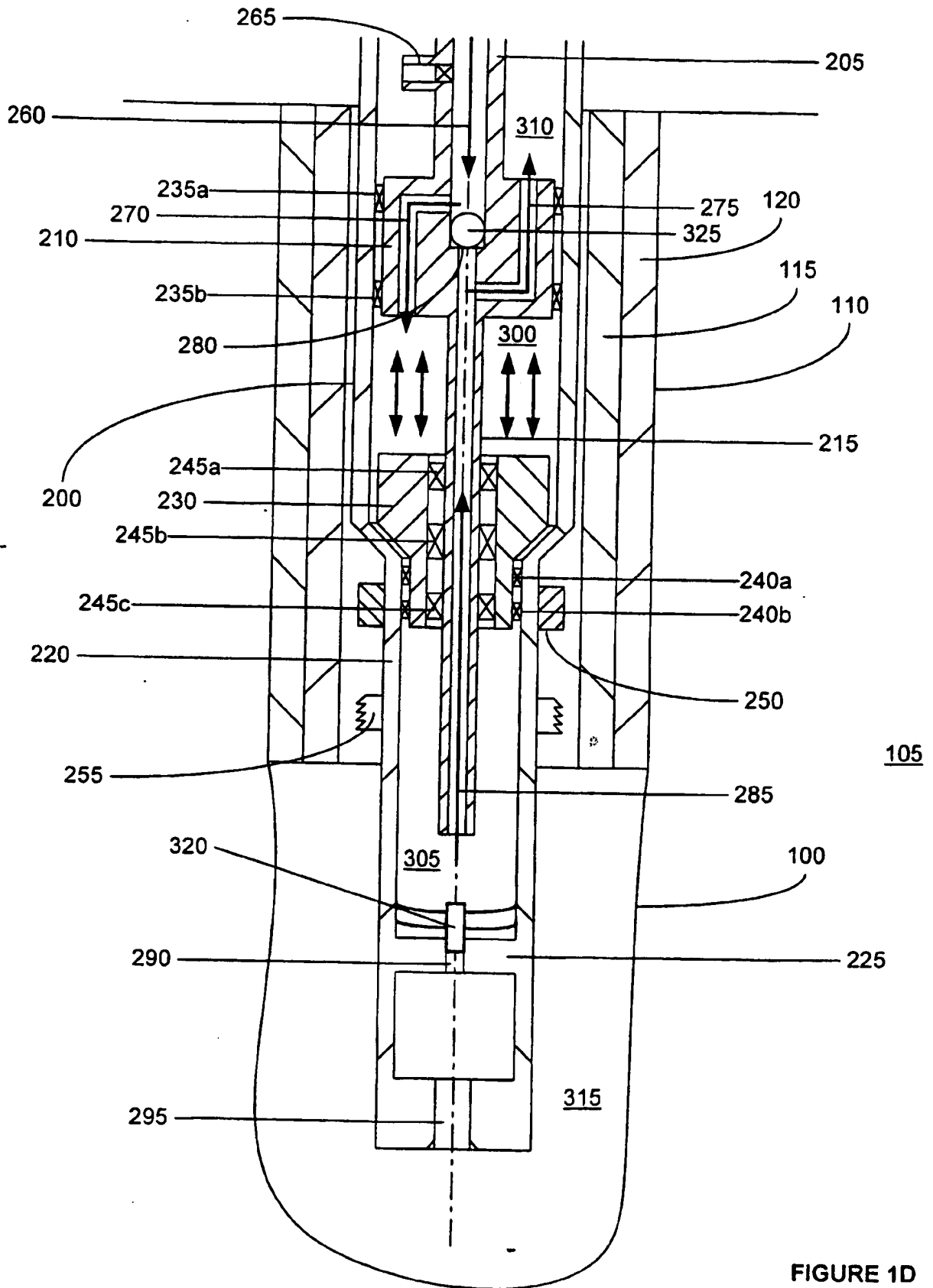

FIGURE 1D

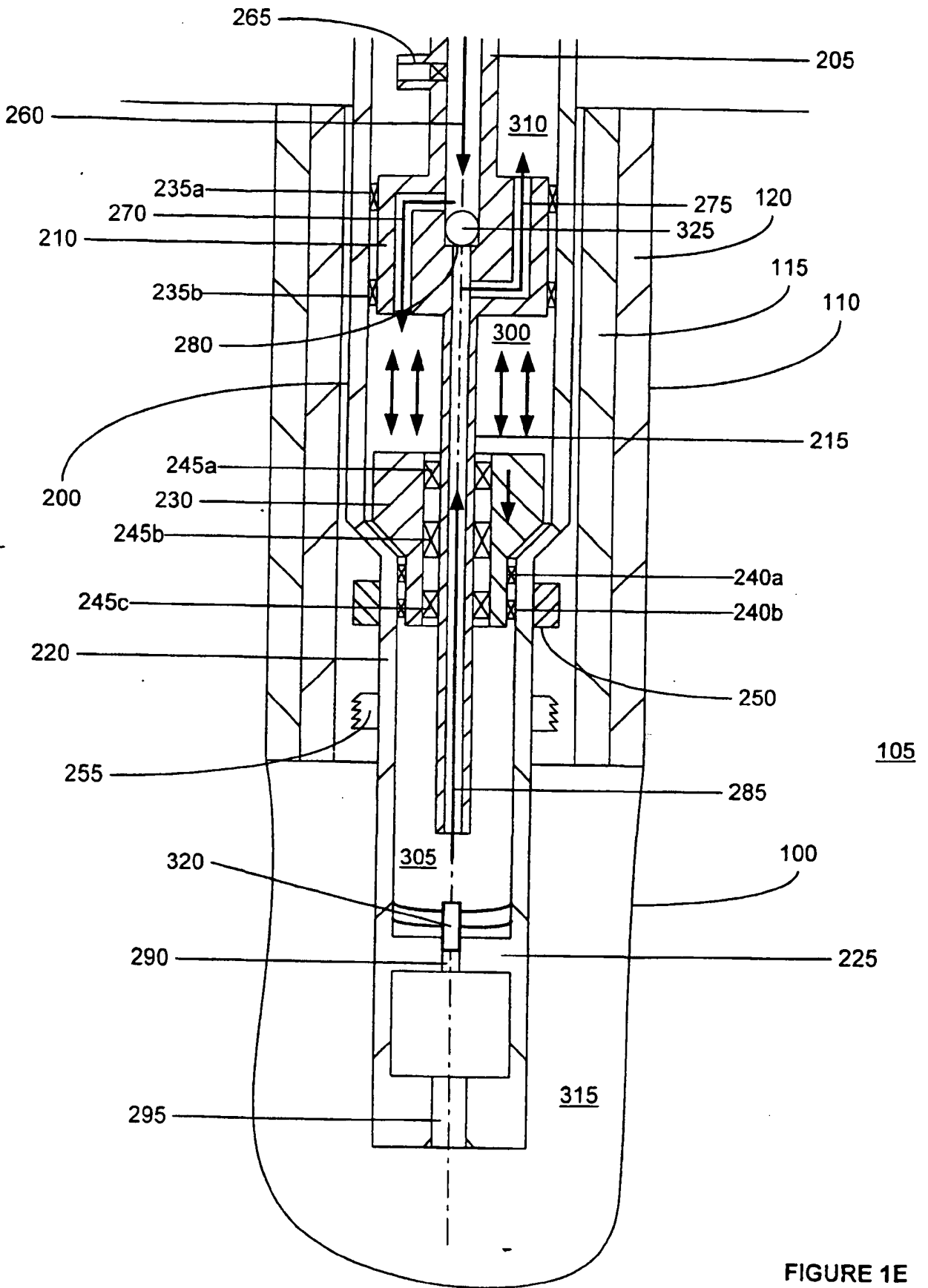

FIGURE 1E

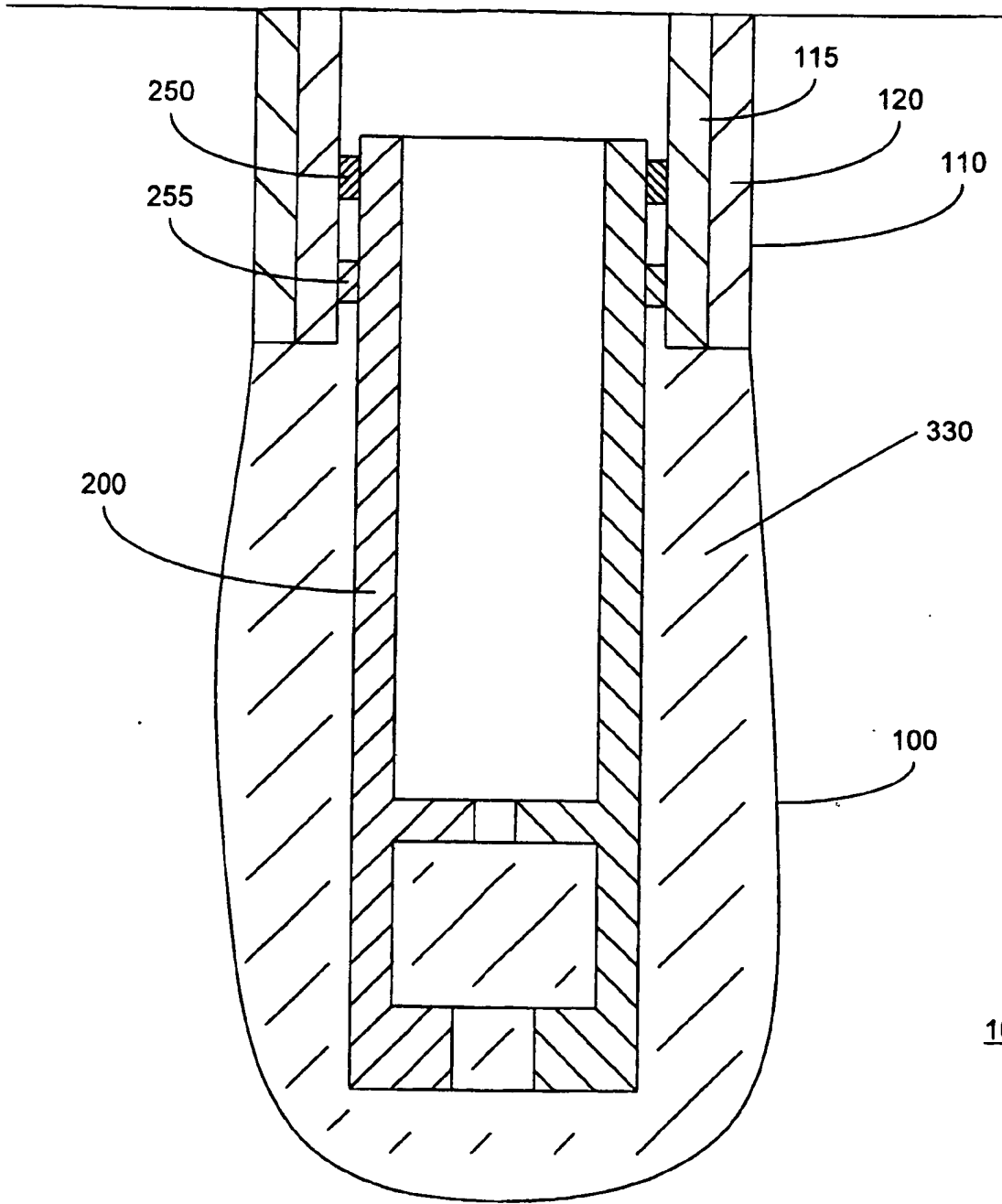

FIGURE 1F

7/79

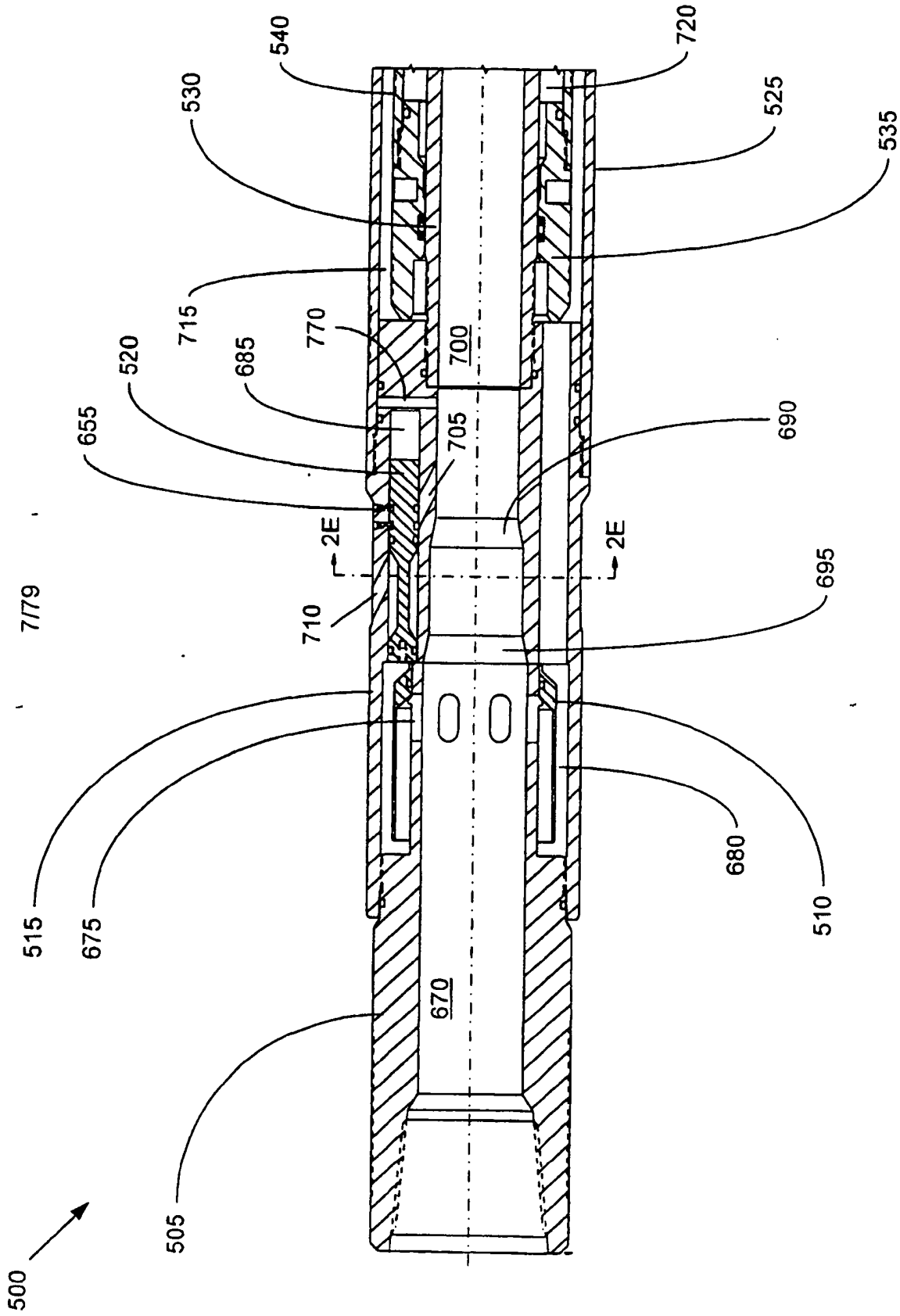

FIGURE 2A

8/79

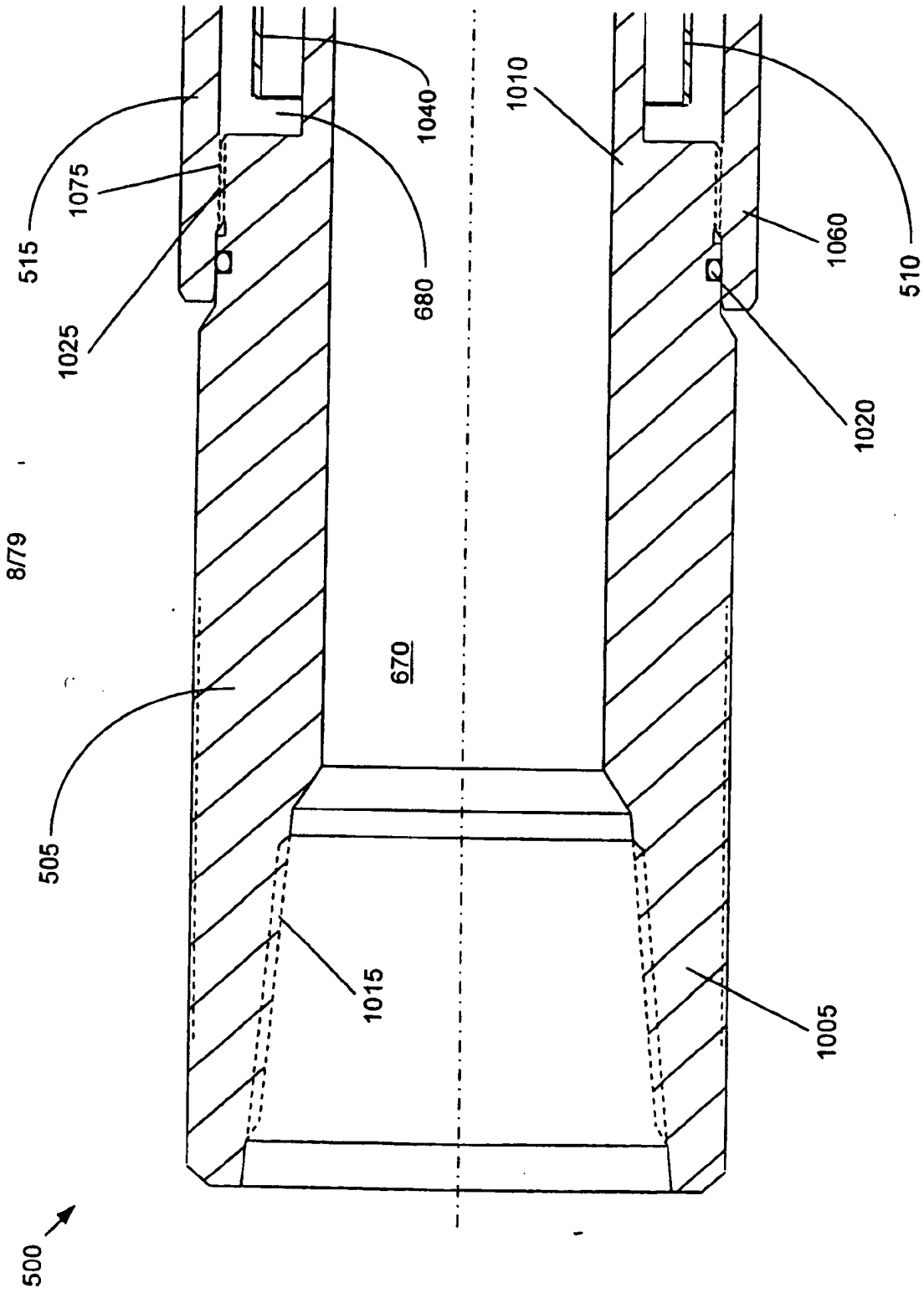

FIGURE 2B

9/19

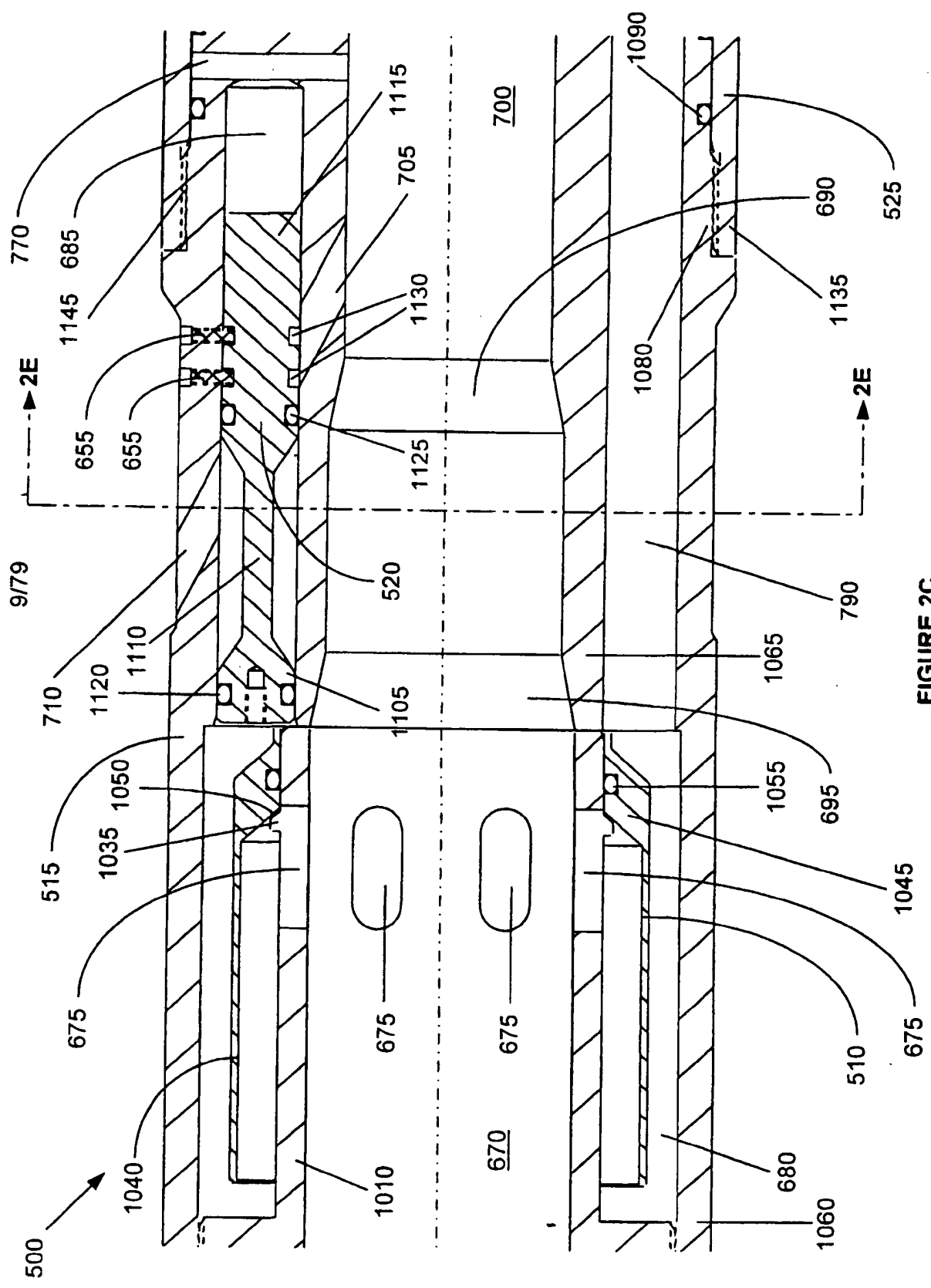

FIGURE 2C

1d79

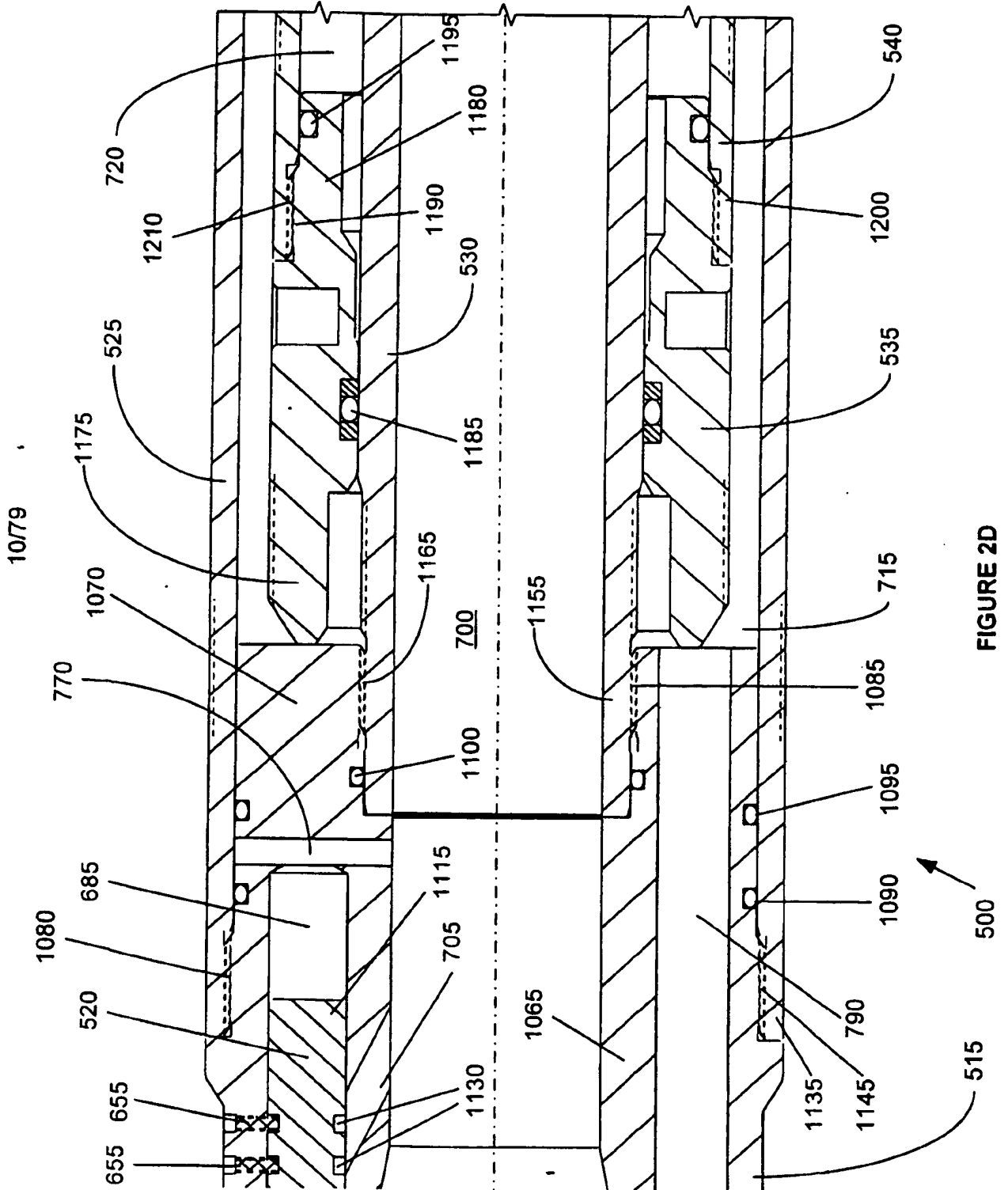

FIGURE 2D

500

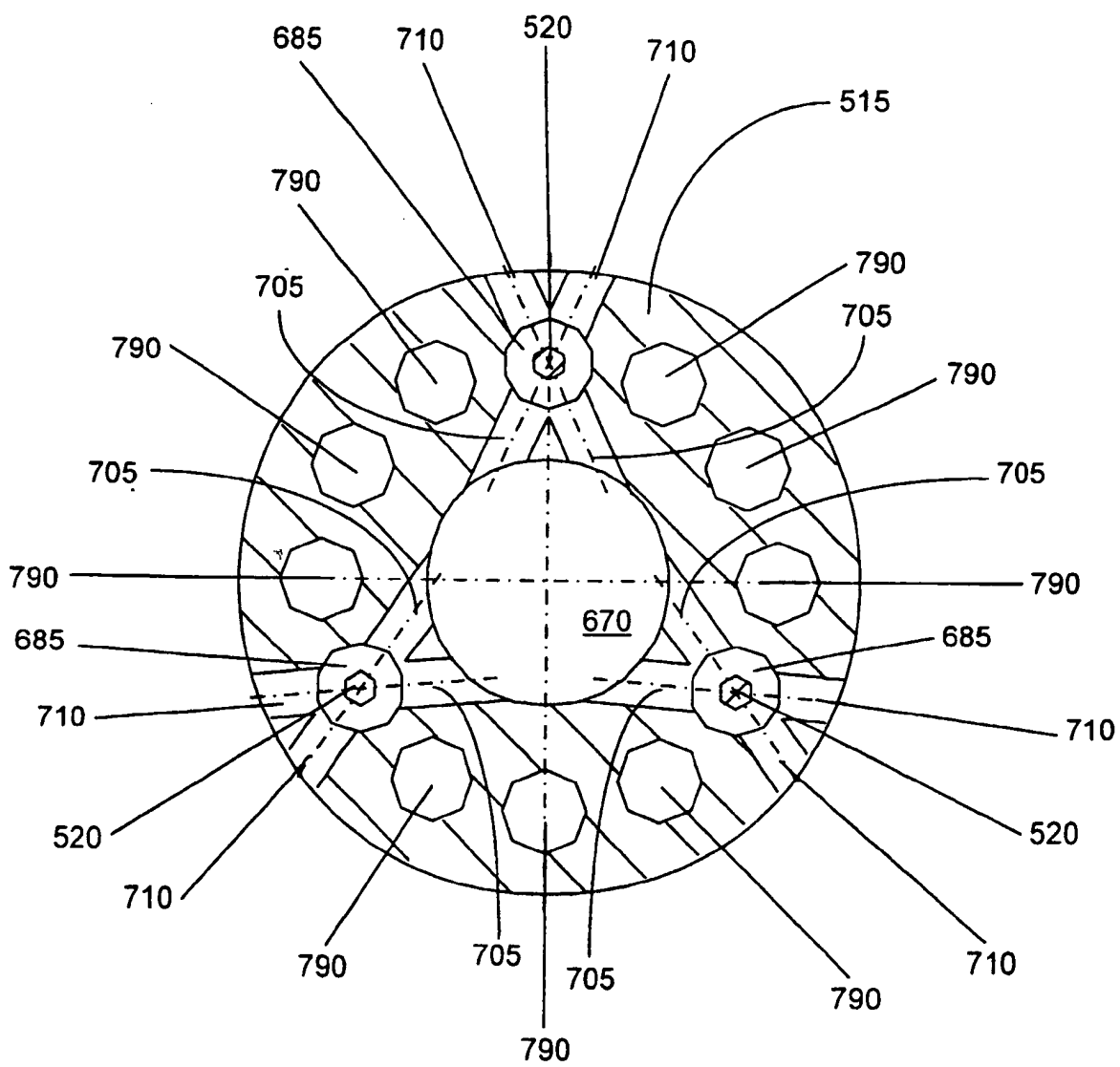

FIGURE 2E

12(79

12/79

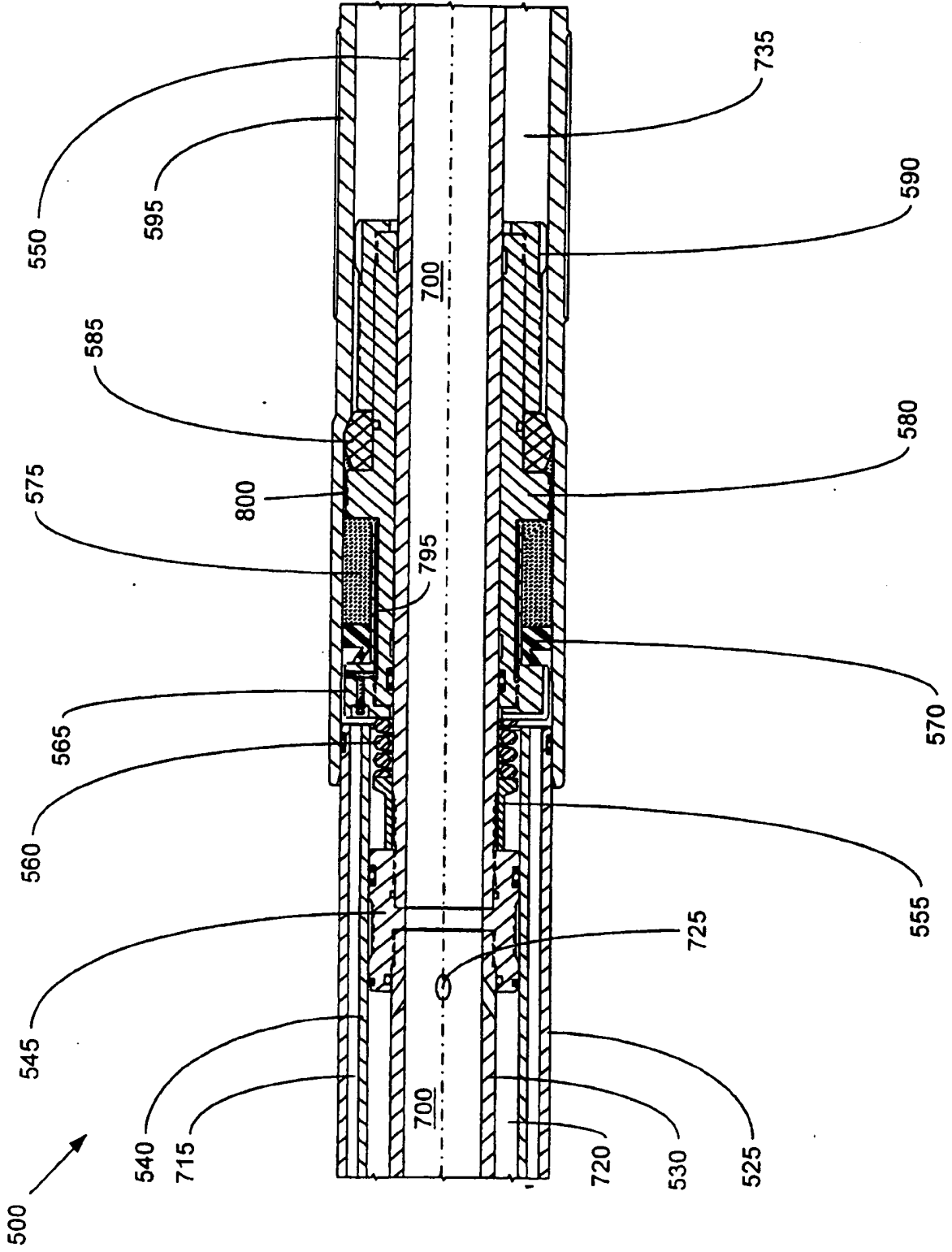

FIGURE 2F

13/79

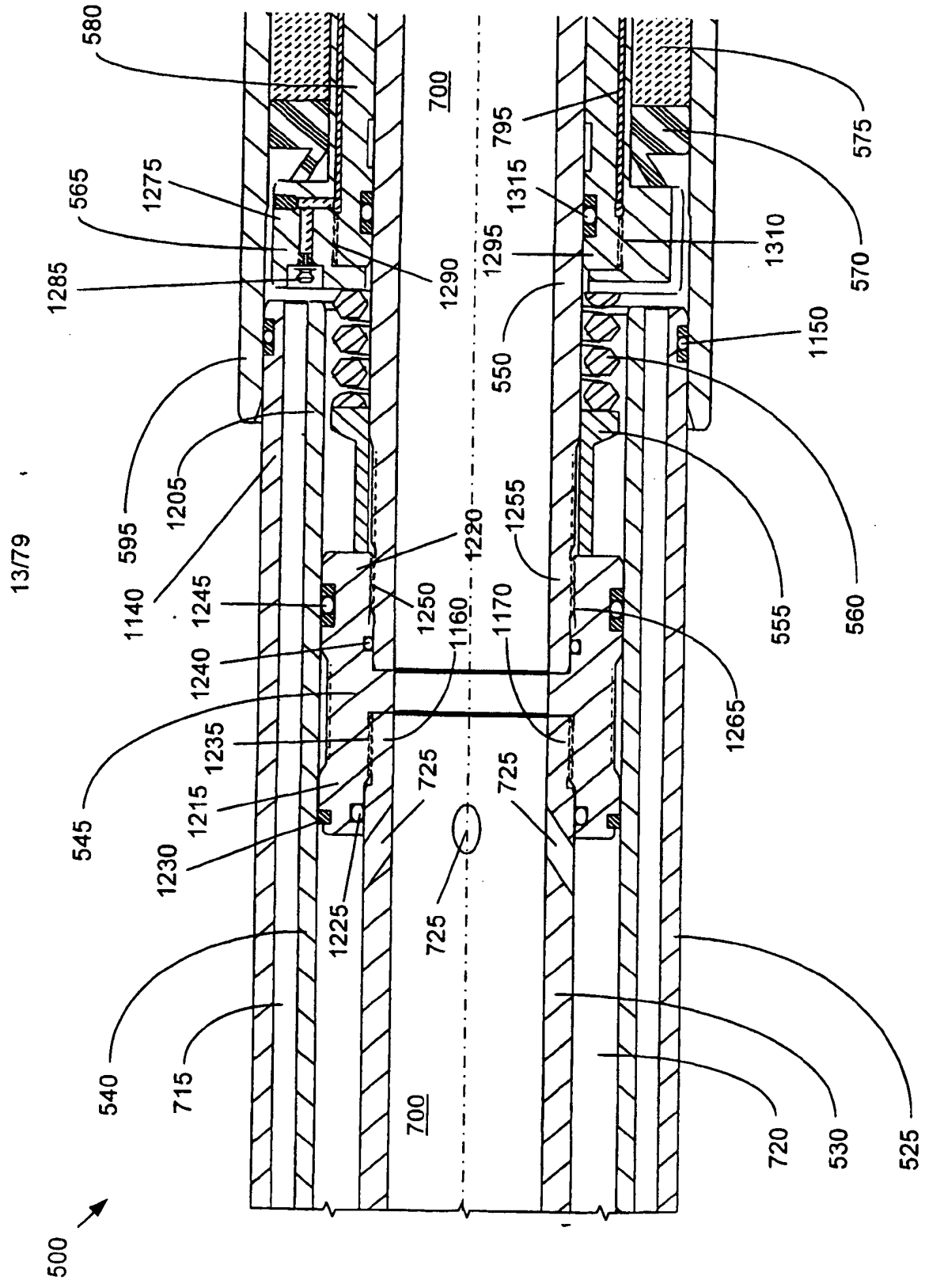

FIGURE 2G

14(79

14/79

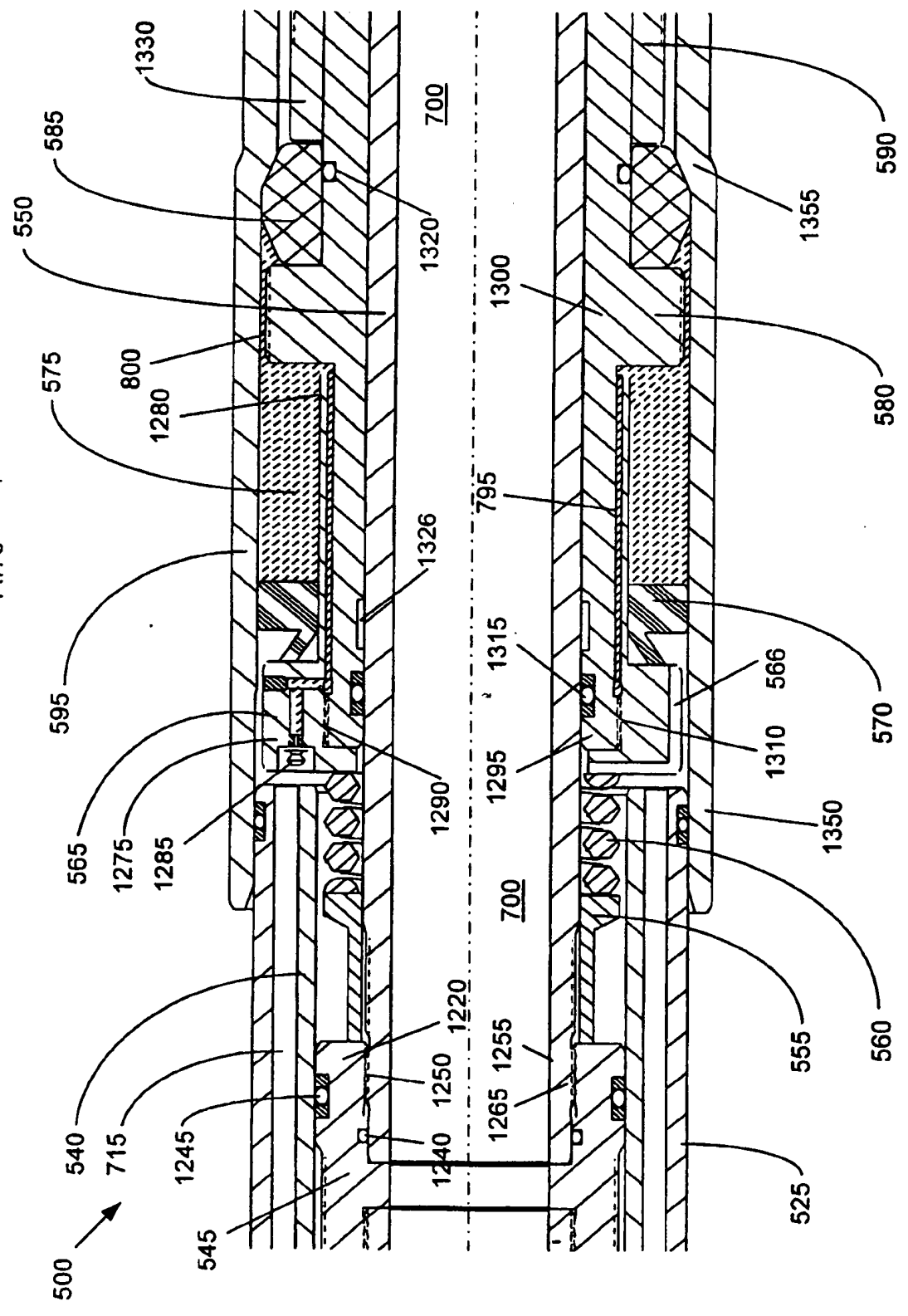

FIGURE 2H

3

15/79

15/79

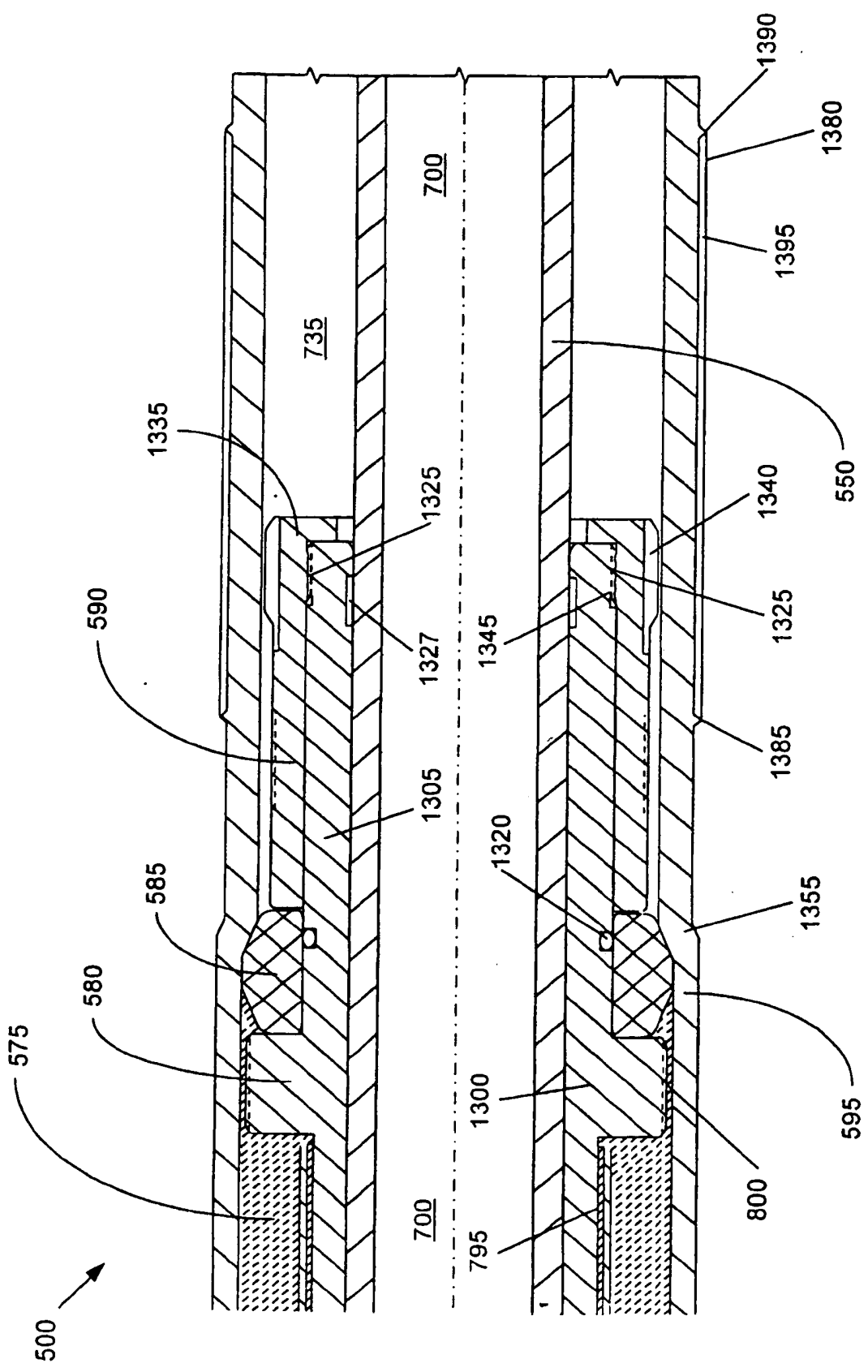

FIGURE 21

16/79

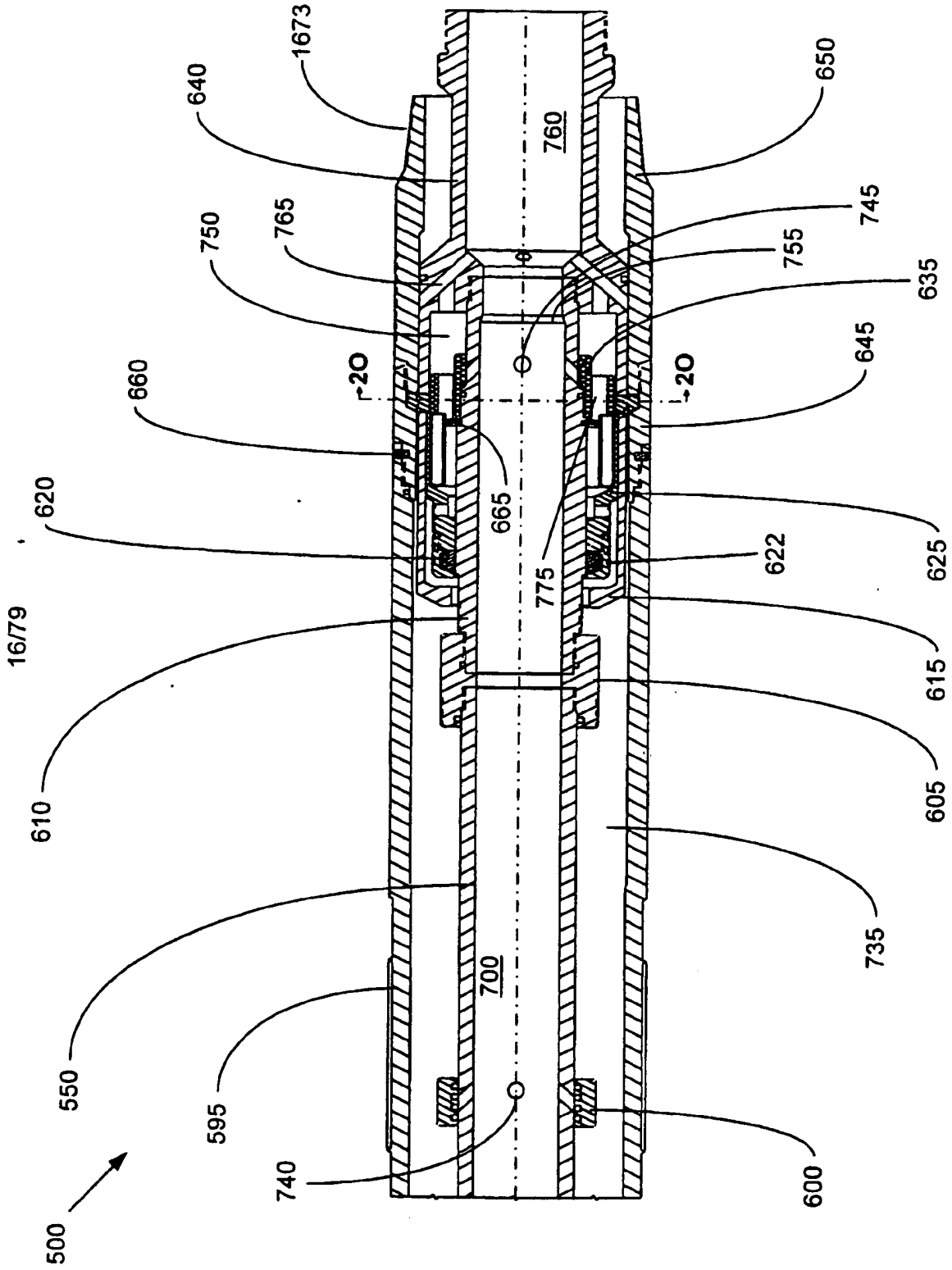

FIGURE 2J

17

17(79)

17779

500

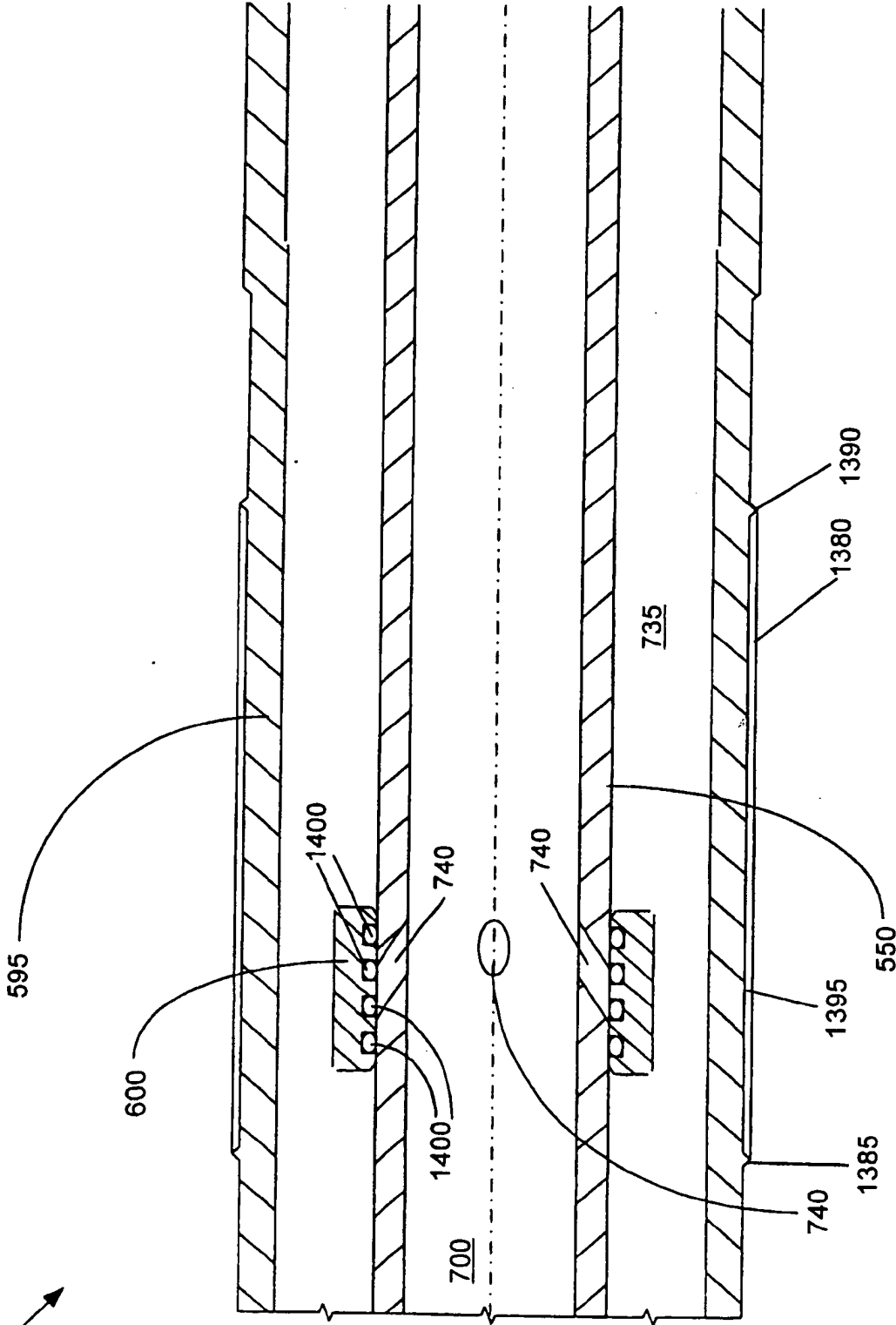

FIGURE 2K

18/79

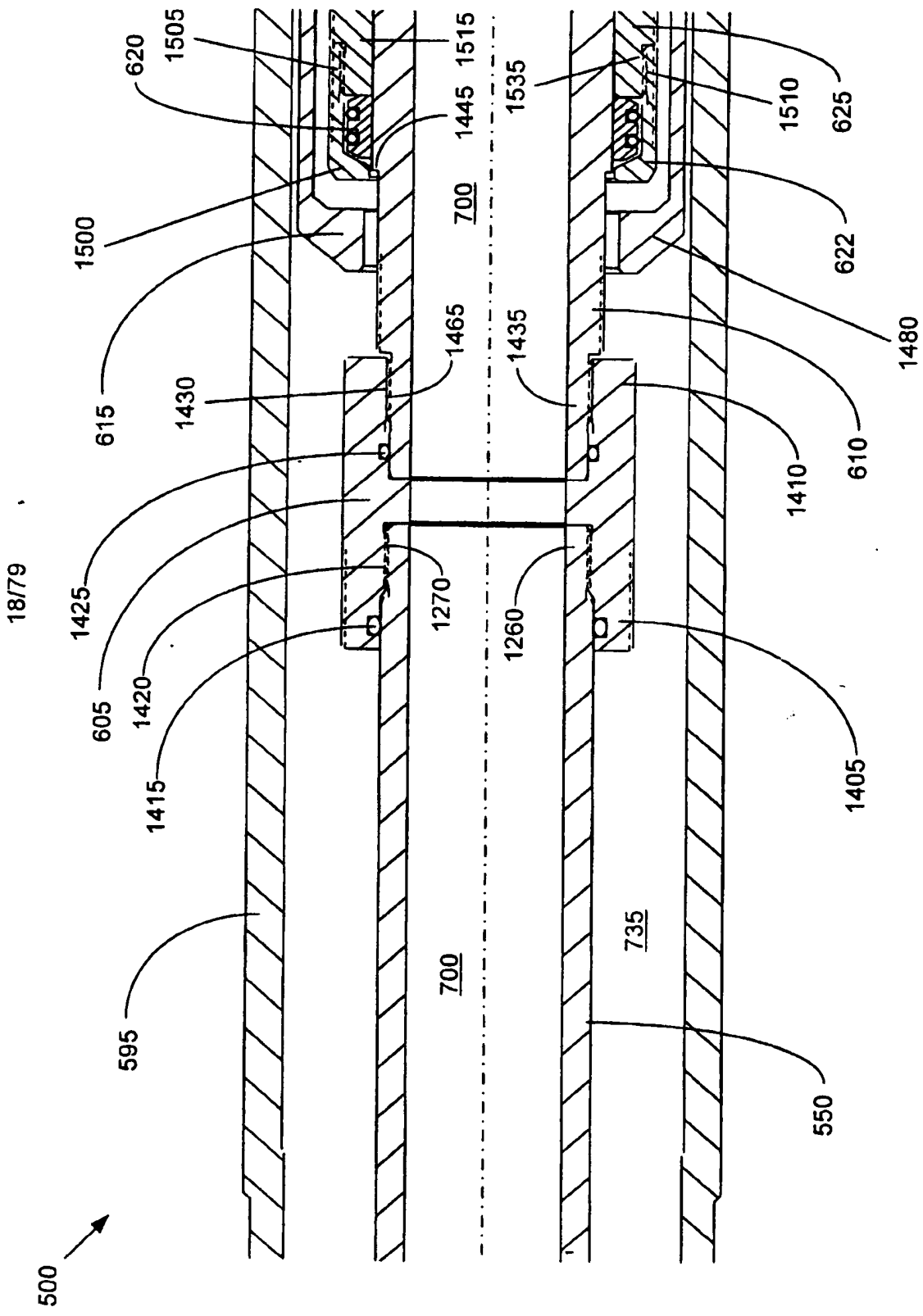

FIGURE 2L

19/79

19/79

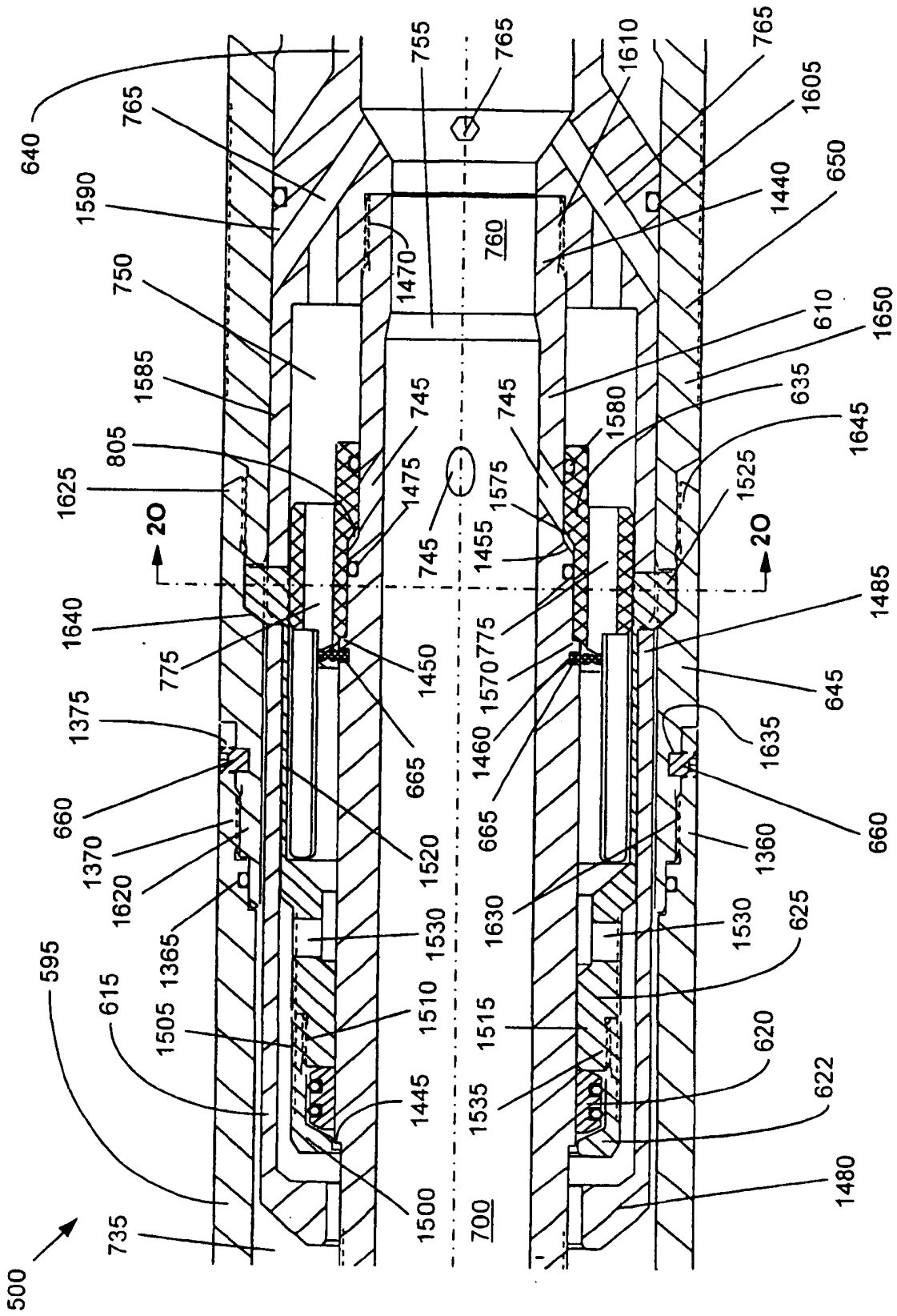

FIGURE 2M

20/79

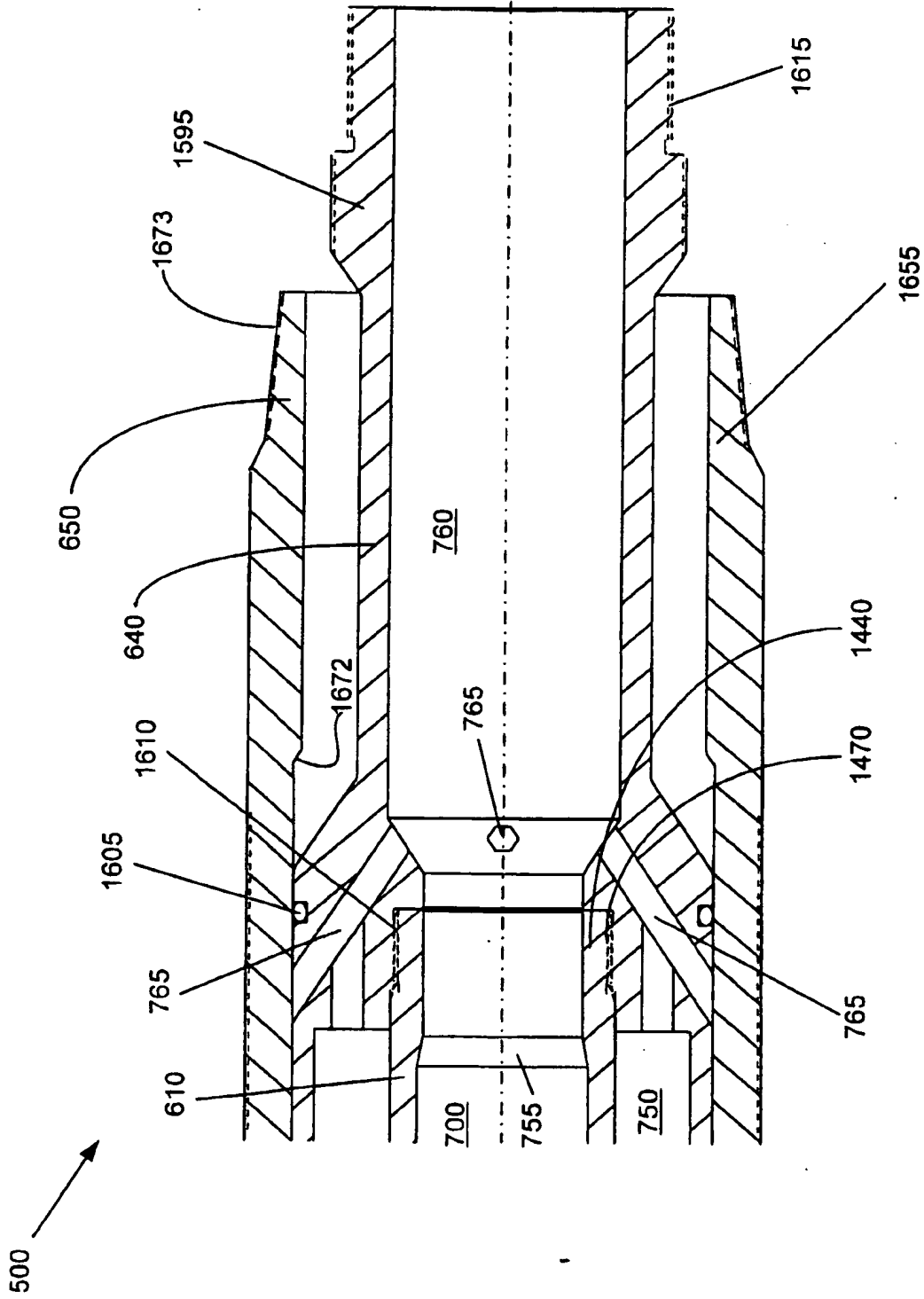

FIGURE 2N

1 2 3 4 5 6 7 8 9 10 11 12 13 14 15 16 17 18 19 20

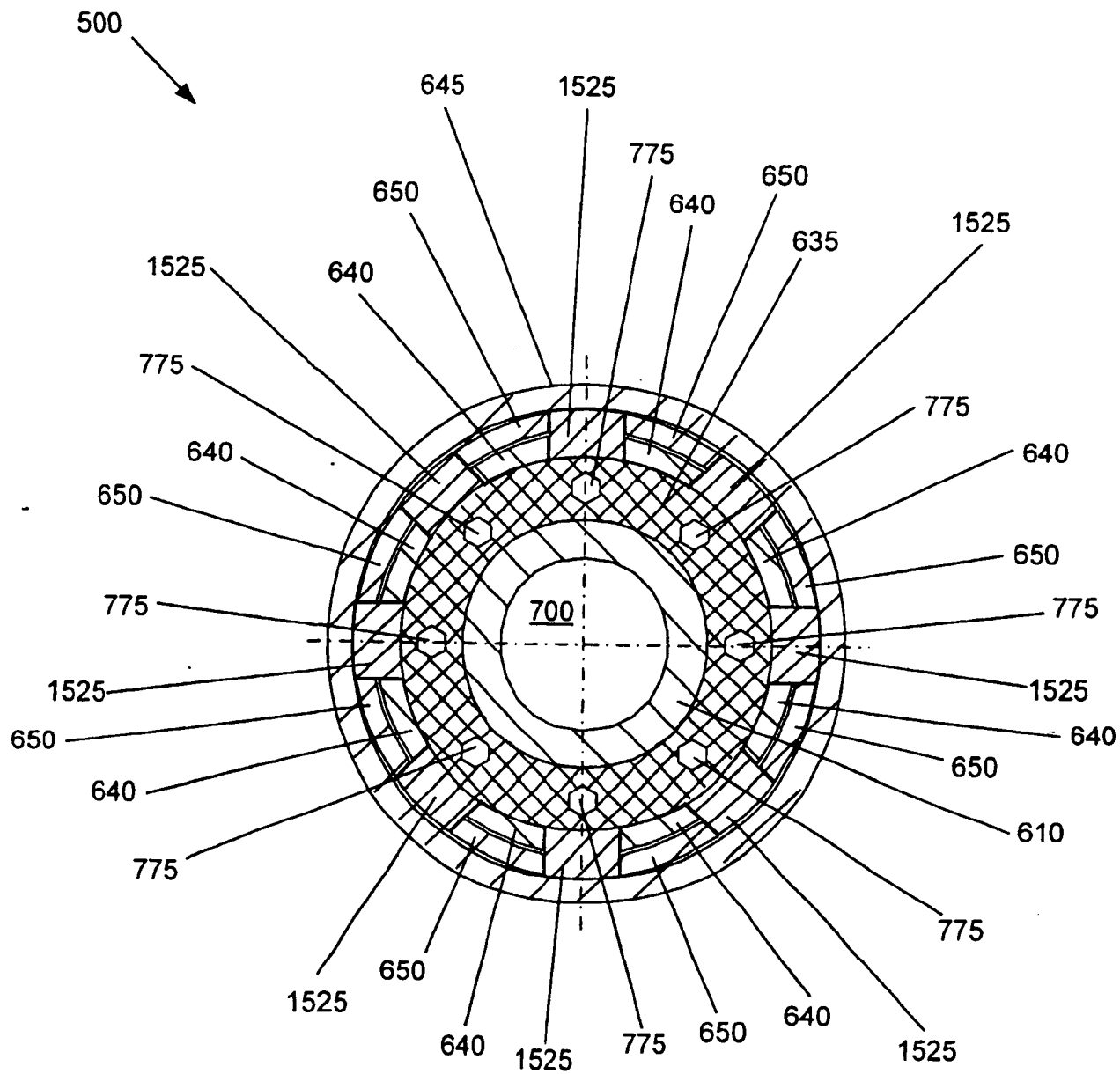

FIGURE 20

22(79

22/79

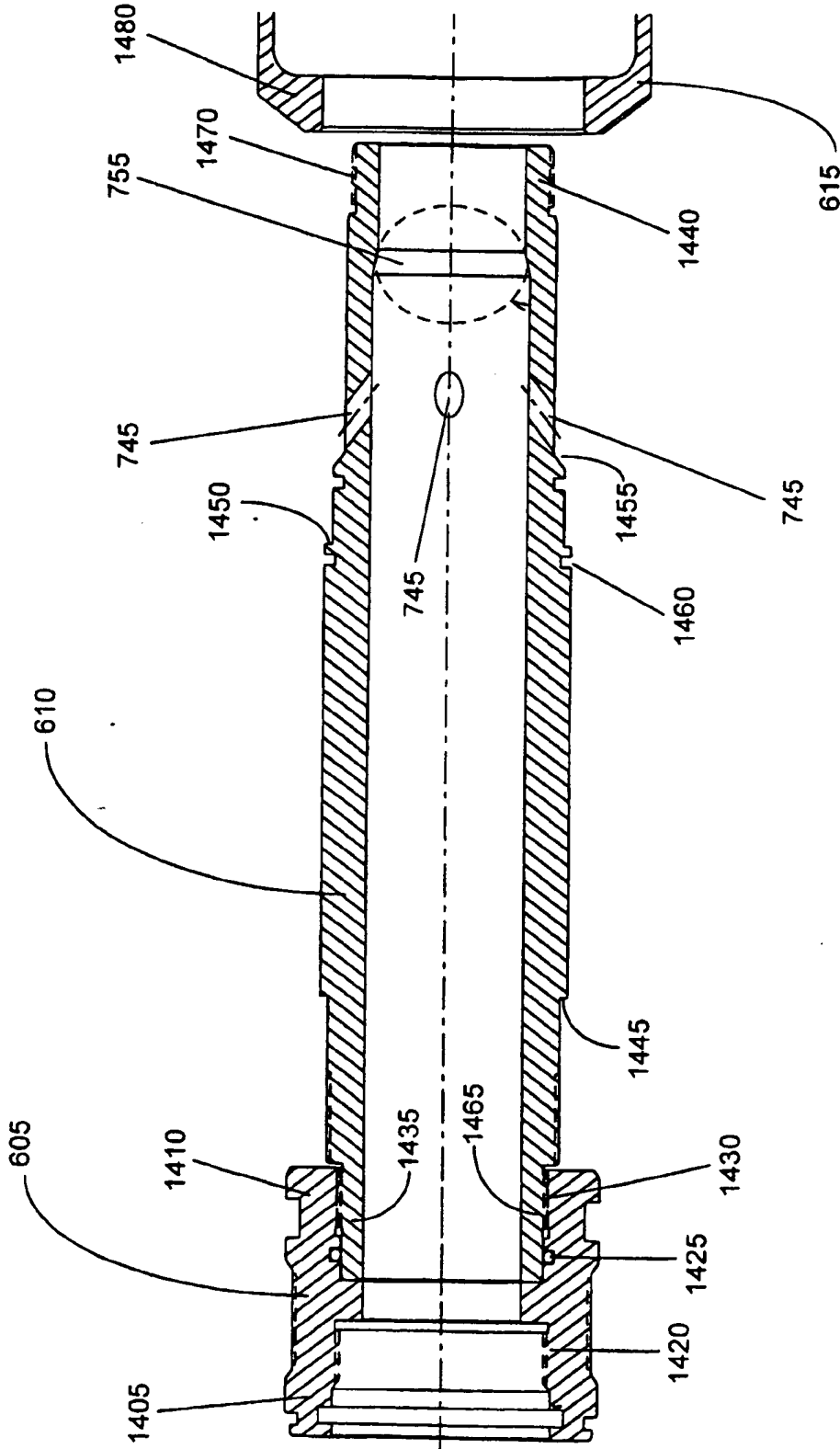

FIGURE 3A

23/79

23/79

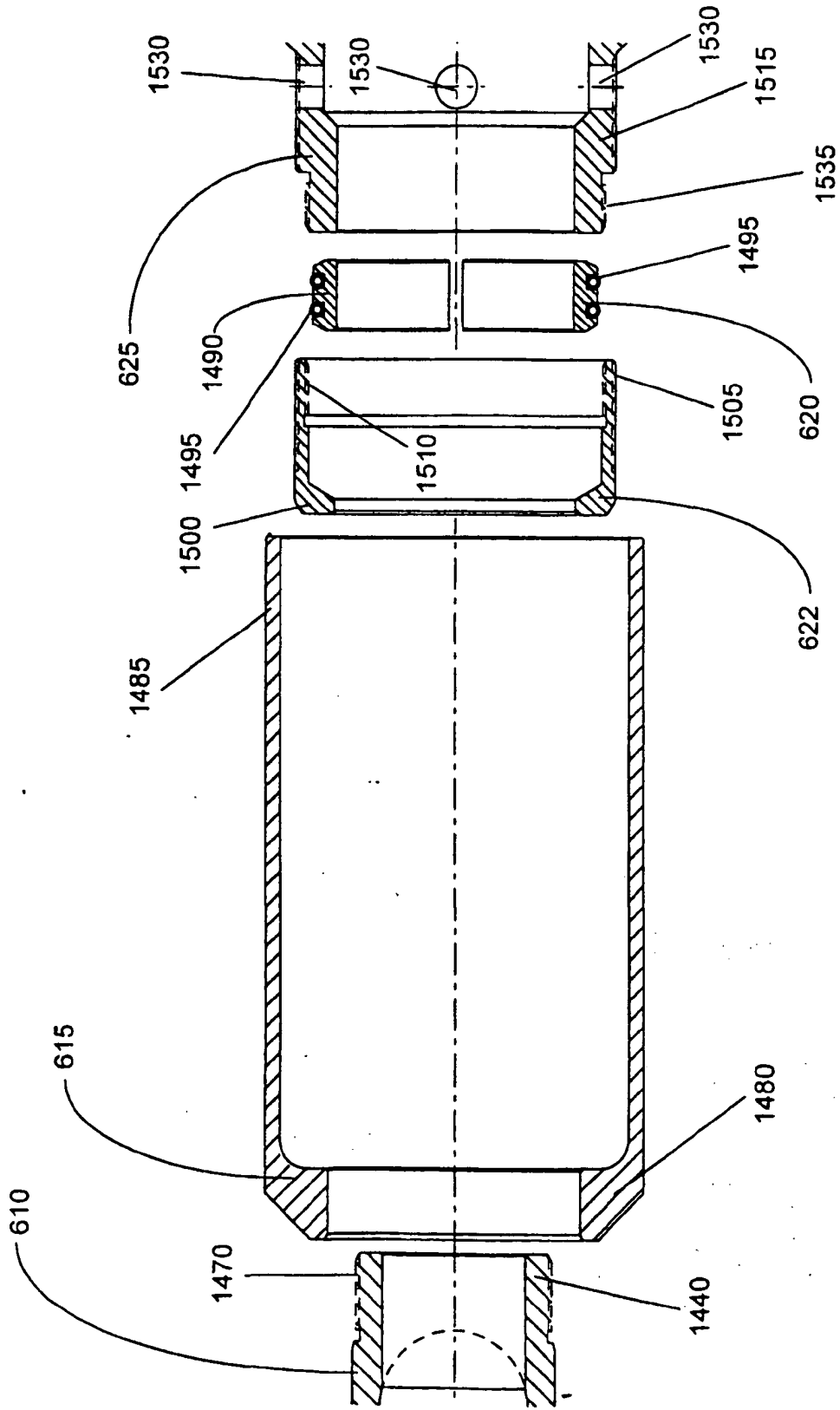

FIGURE 3B

24/79

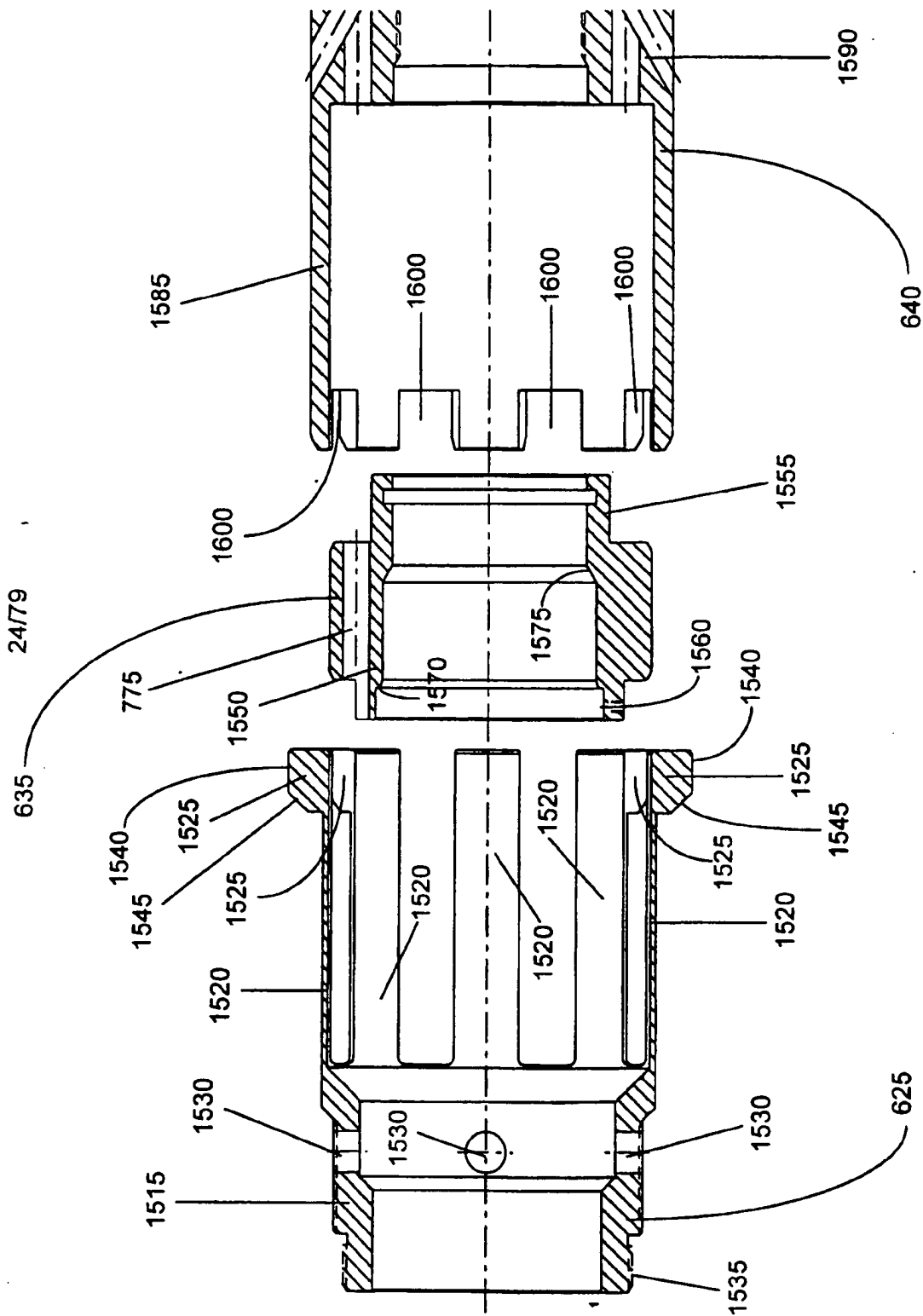

FIGURE 3C

25/79

25/79

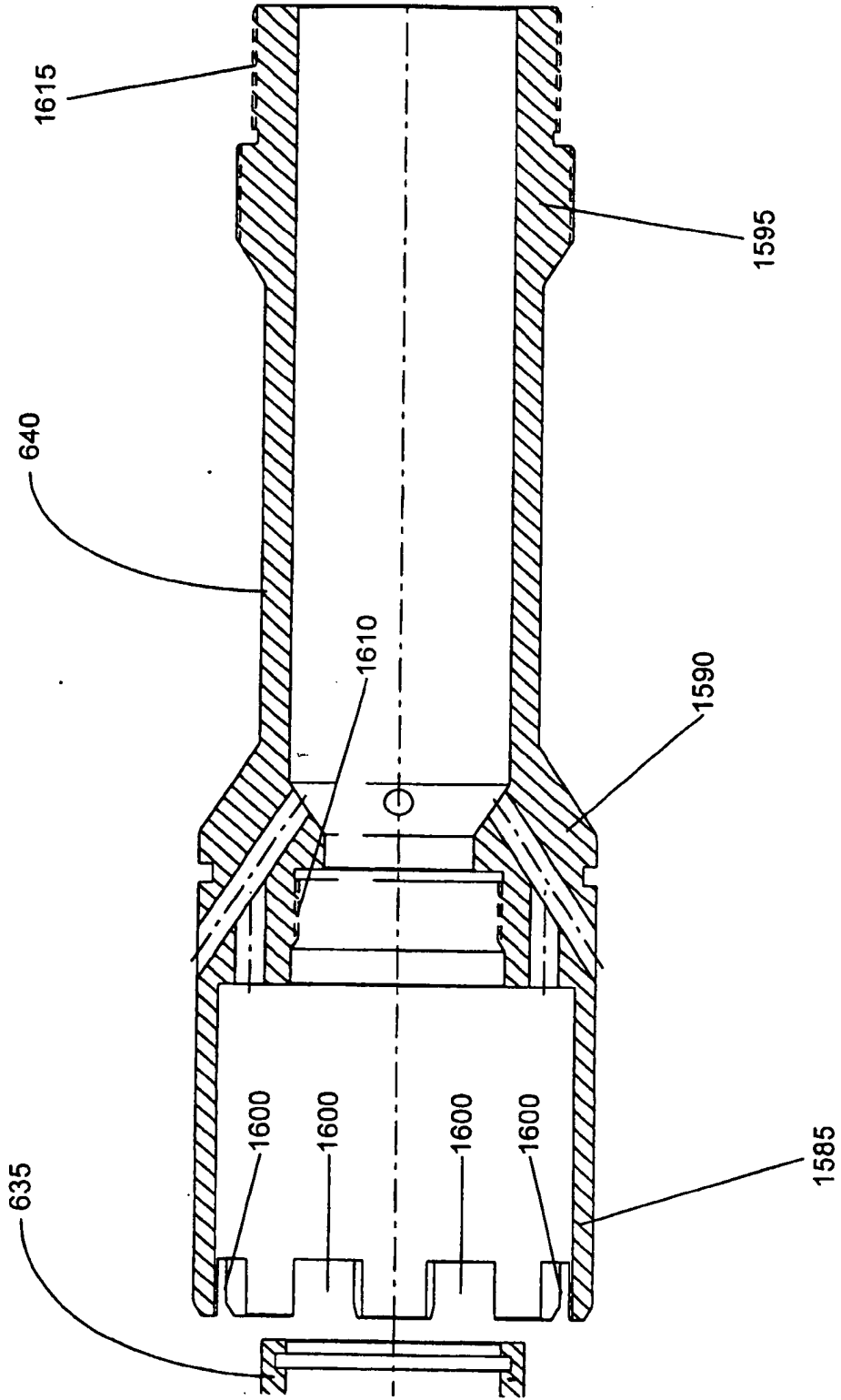

FIGURE 3D

2679

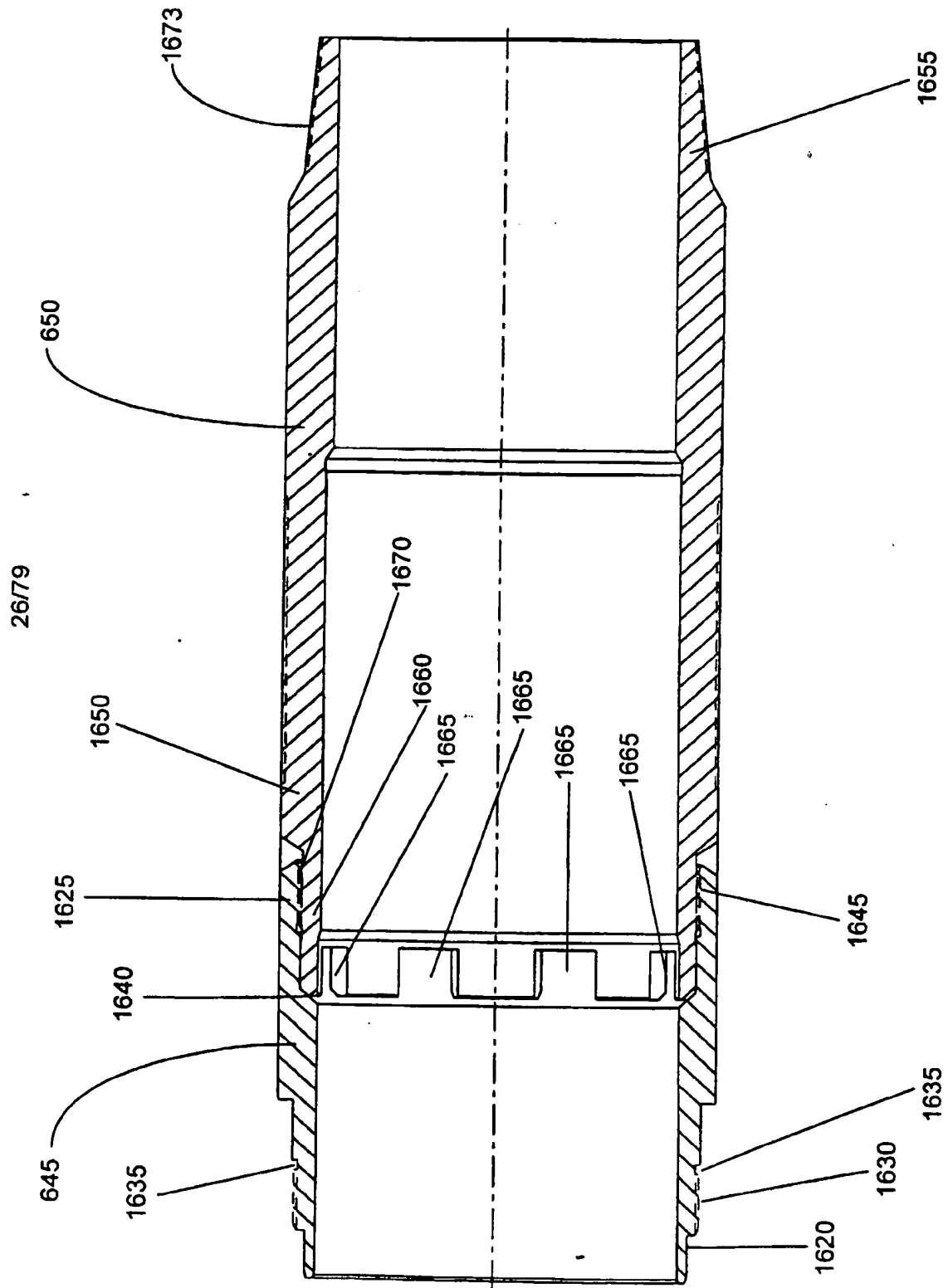
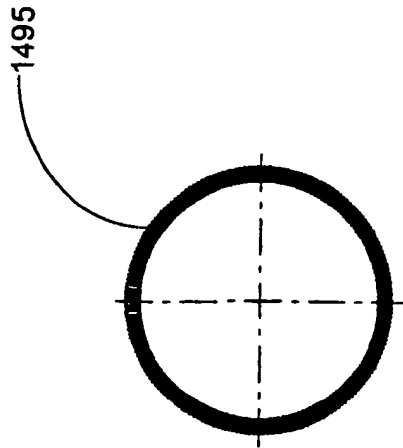

FIGURE 3E

27/99

2779



1495

FIGURE 3F

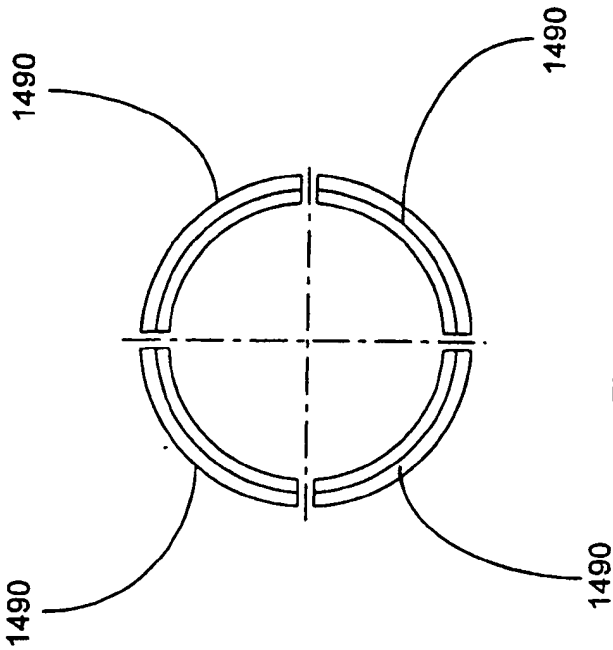

1490

1490

1490

1490

FIGURE 3G

28(79

28/79

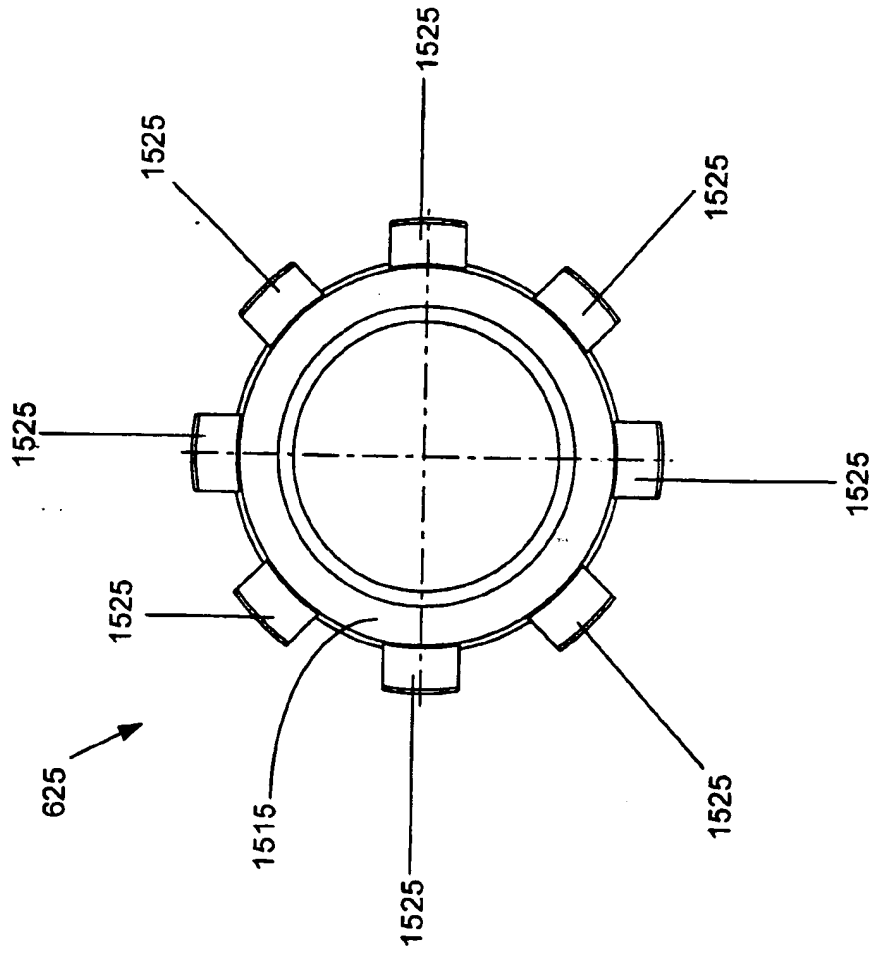

FIGURE 3H

29/19

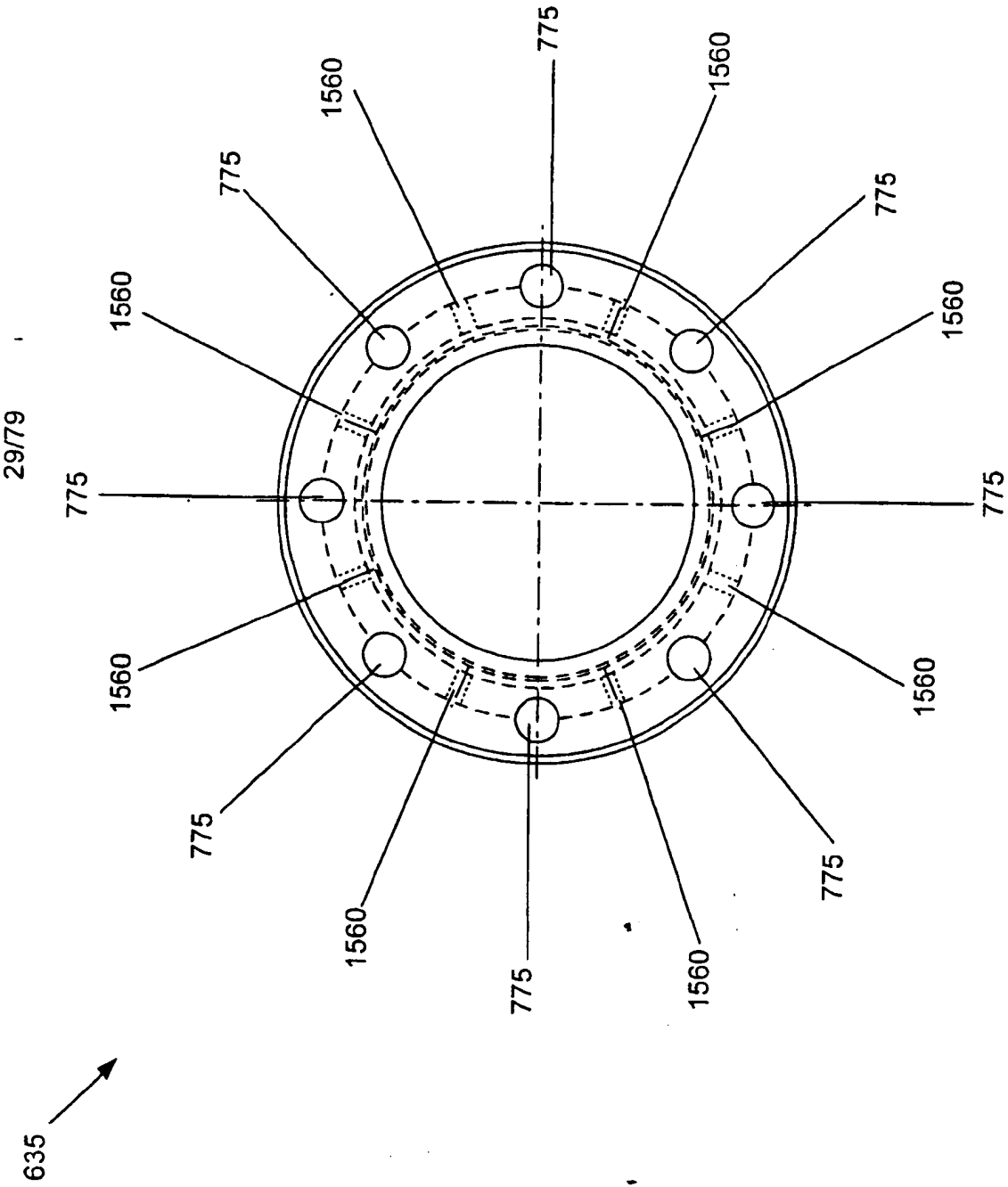

FIGURE 3I

30179

3079

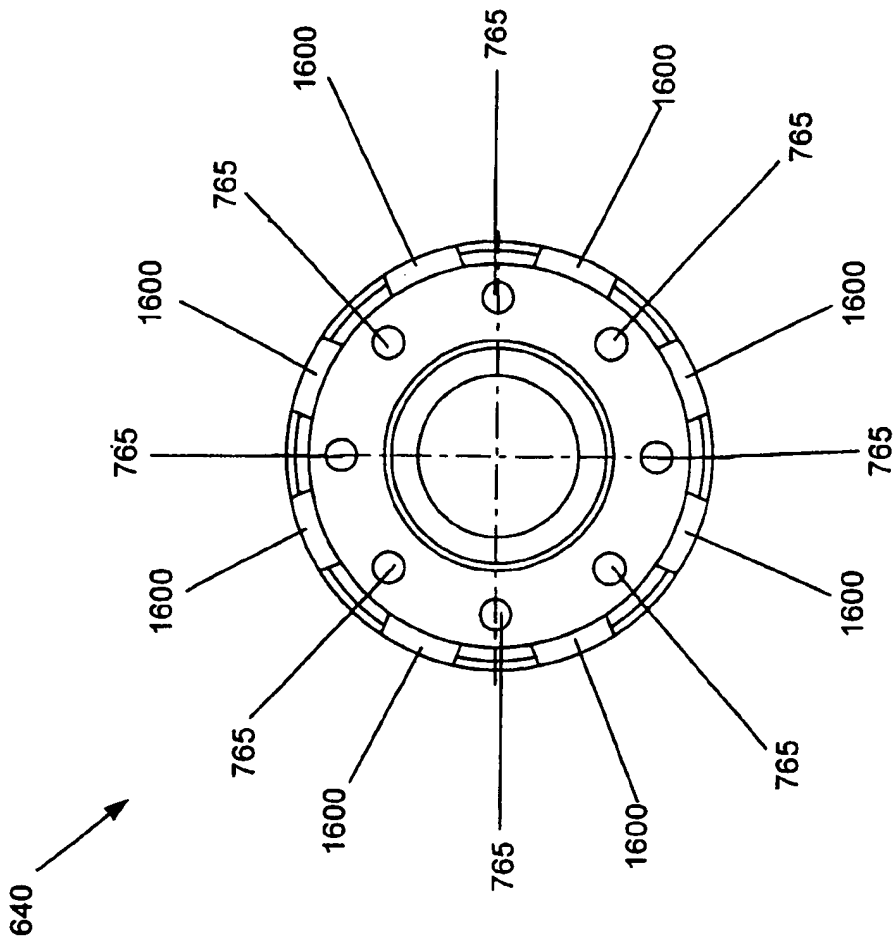

FIGURE 3J

3179

3179

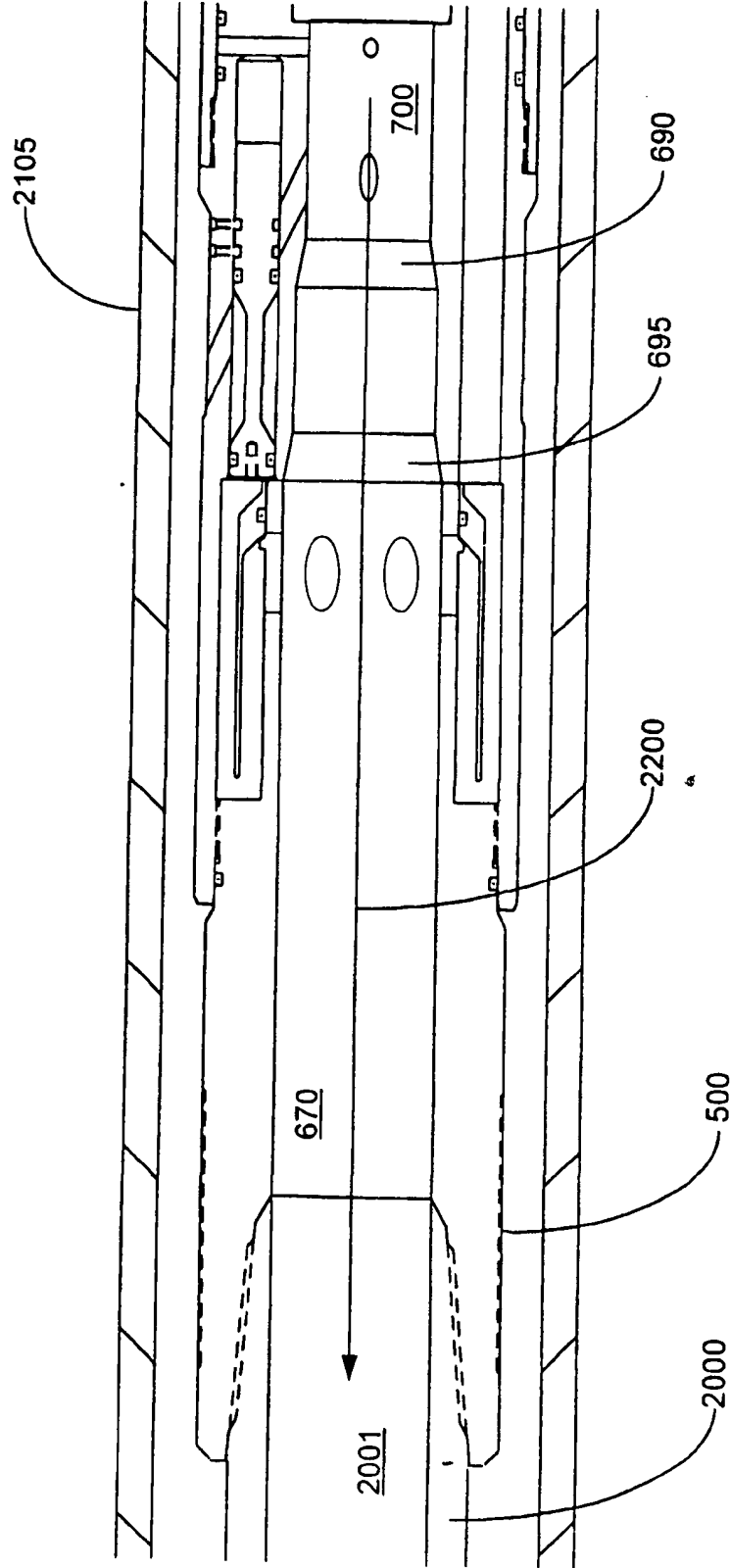

FIGURE 4A

32179

32179

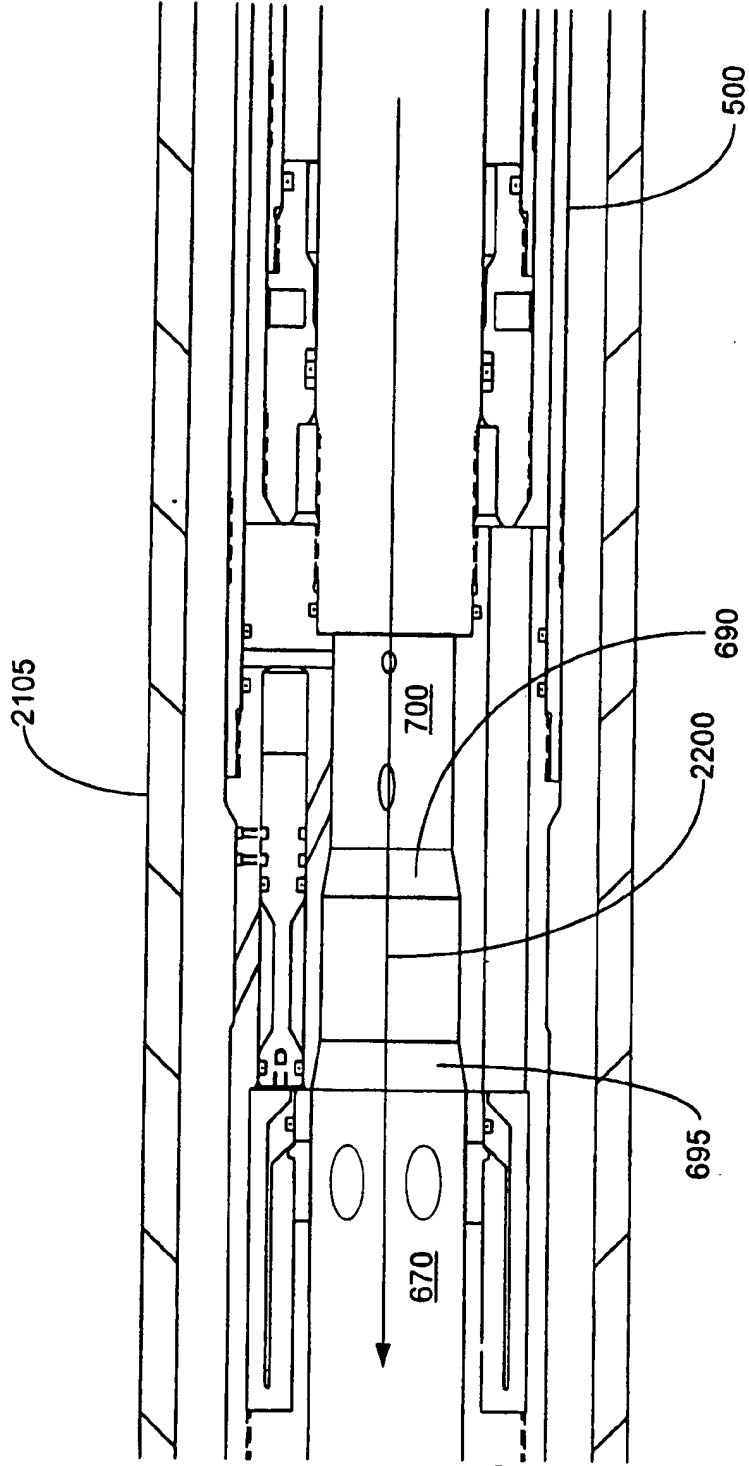

FIGURE 4B

33(79

3379

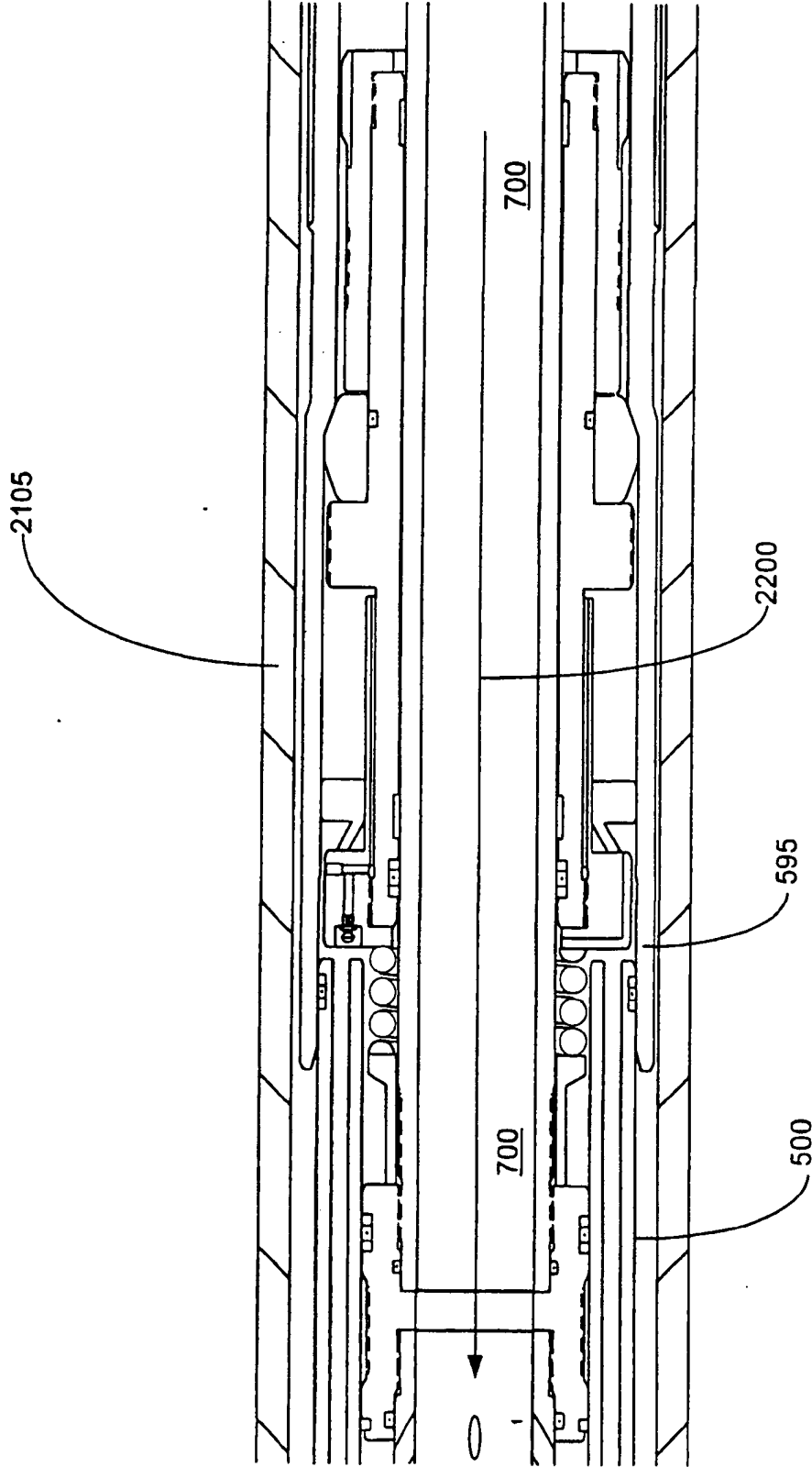

FIGURE 4C

34/79

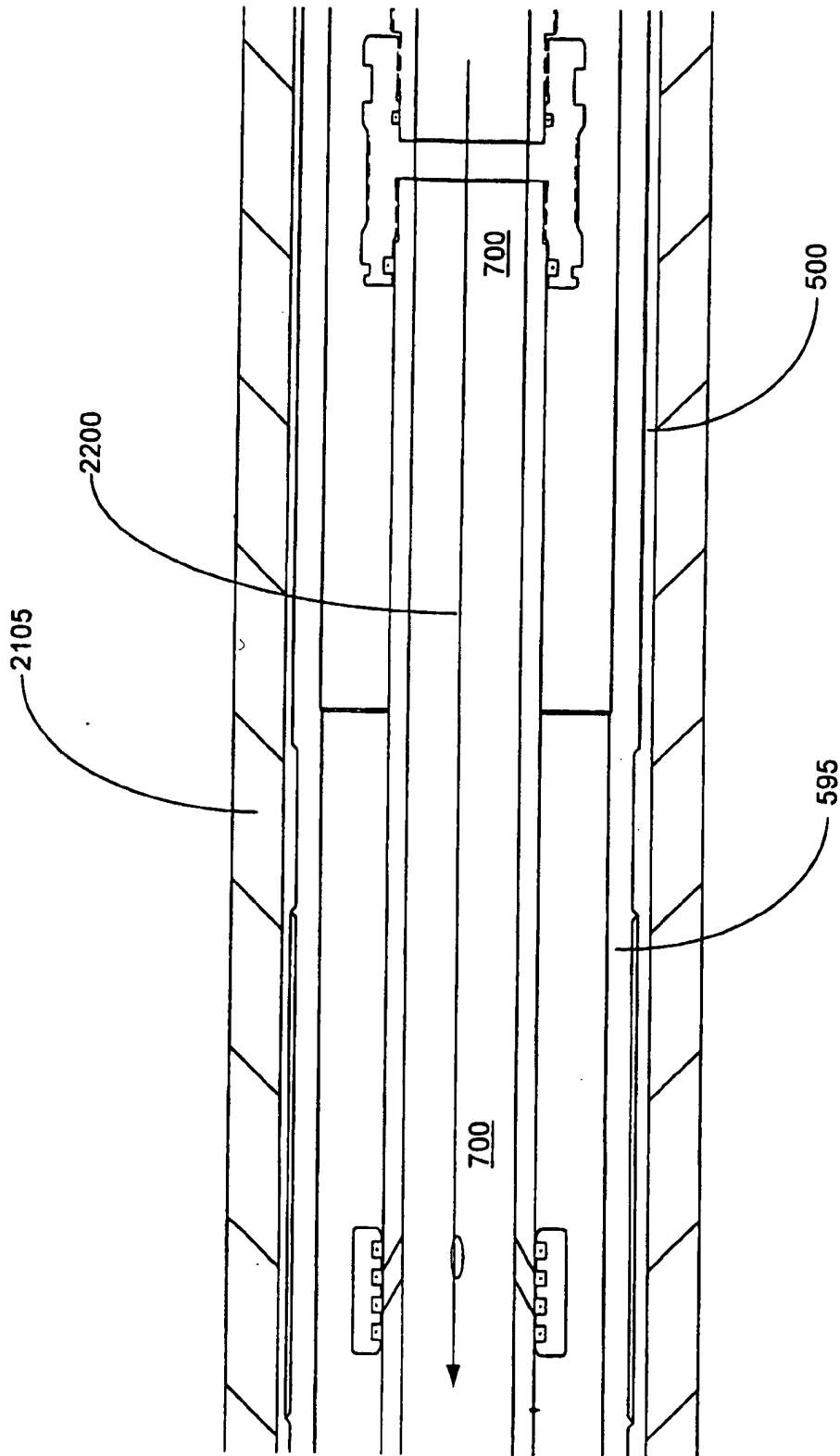

FIGURE 4D

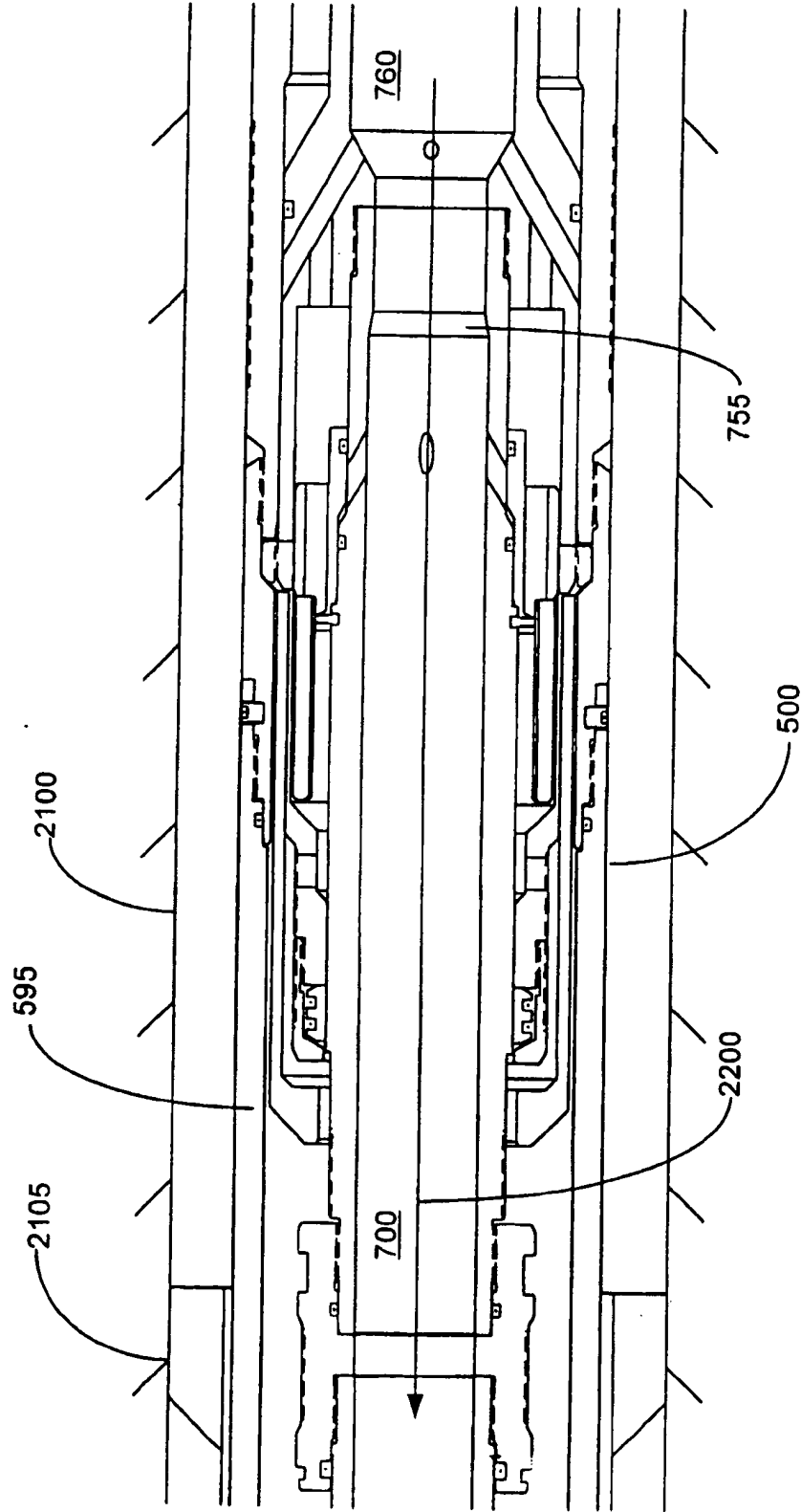

FIGURE 4E

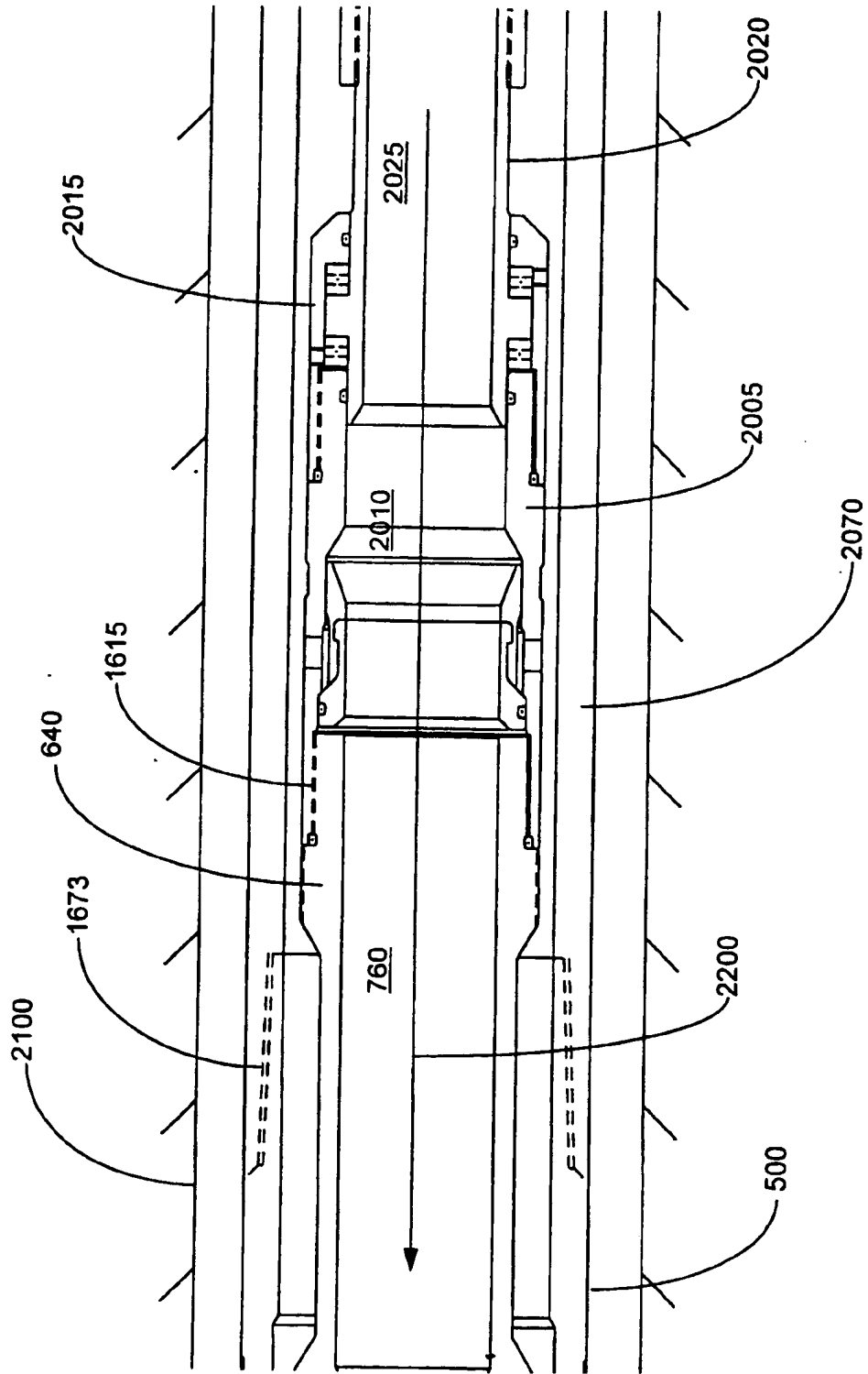

FIGURE 4F

3779

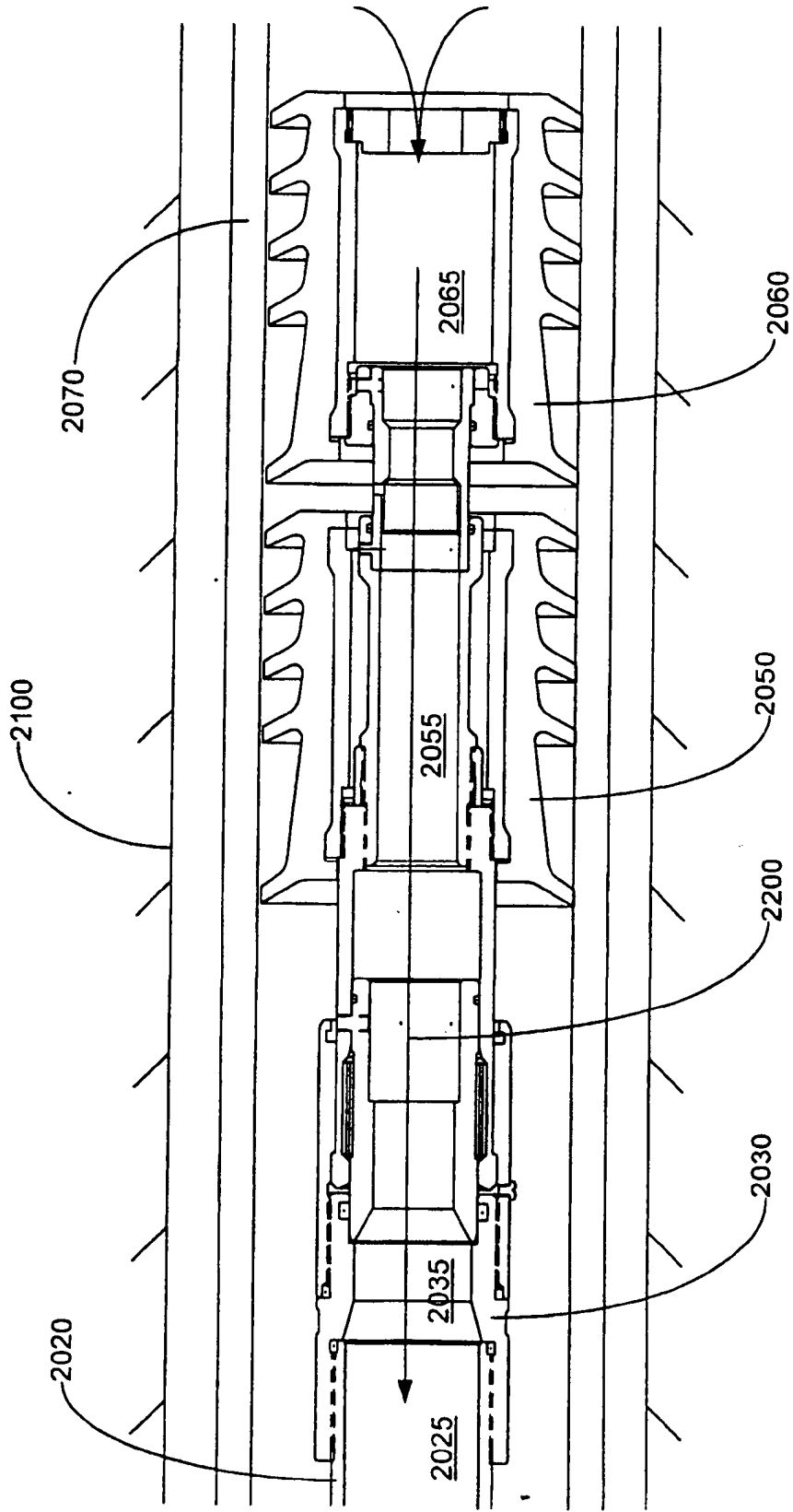

FIGURE 4G

38/79

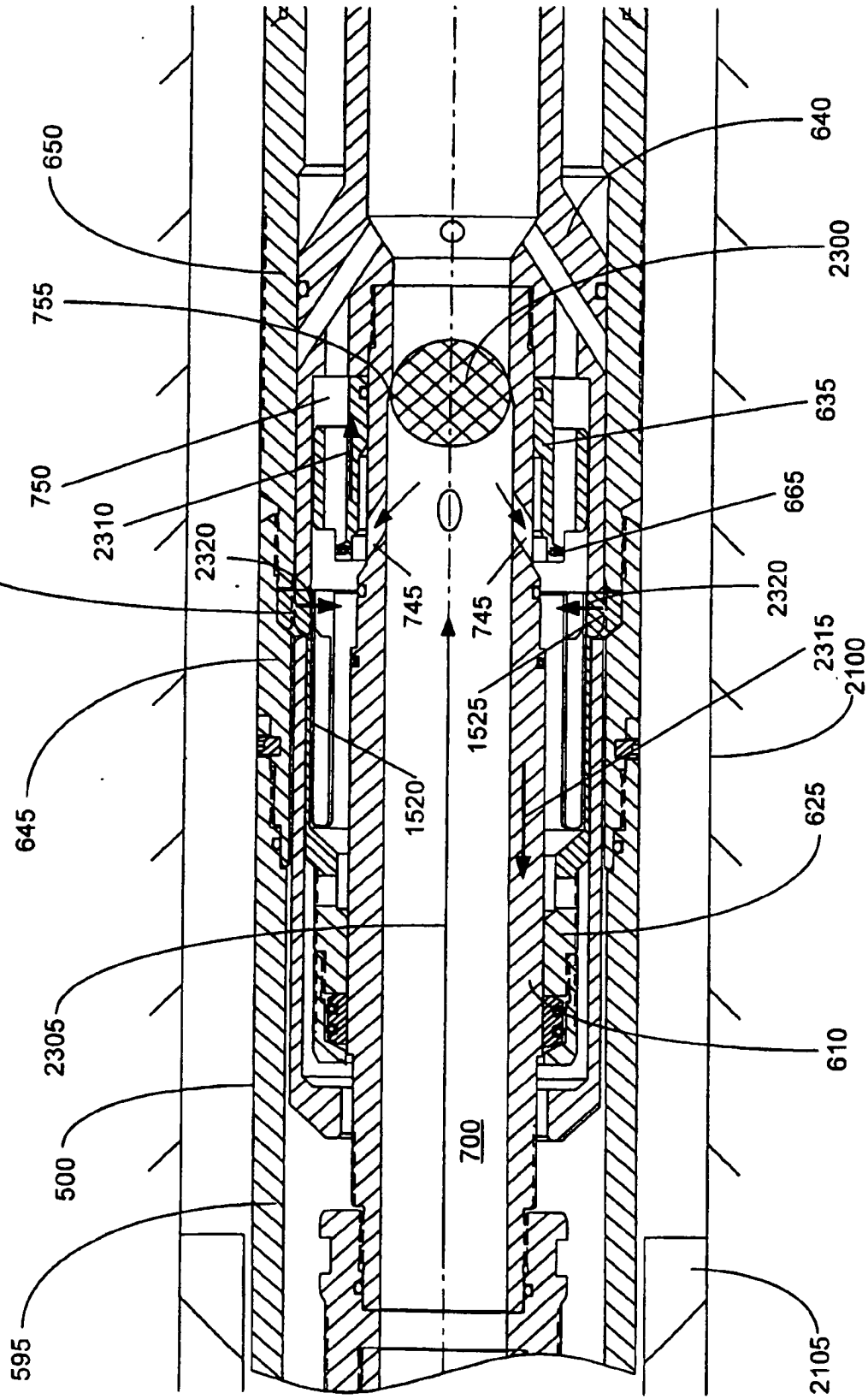

FIGURE 5A

39/79

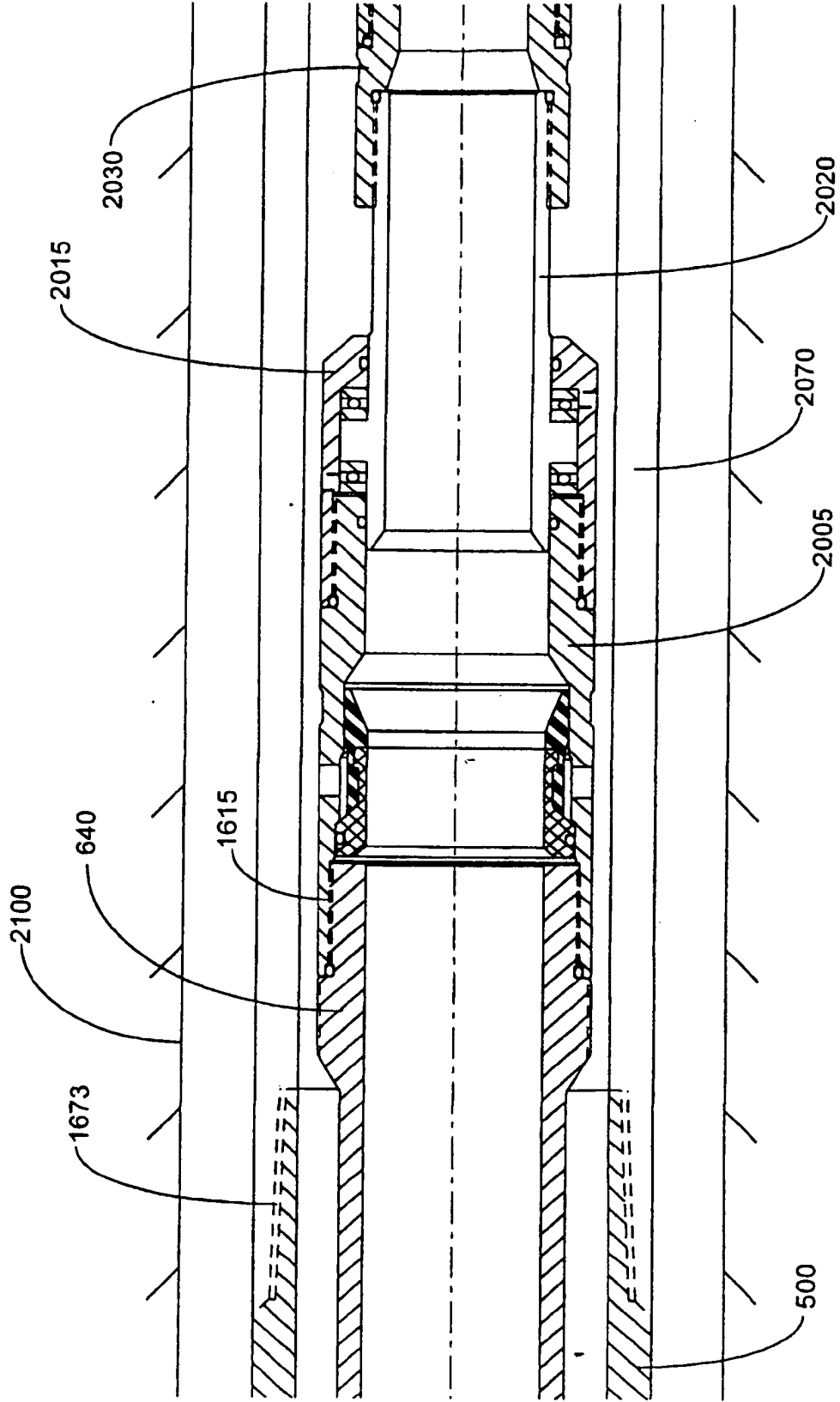
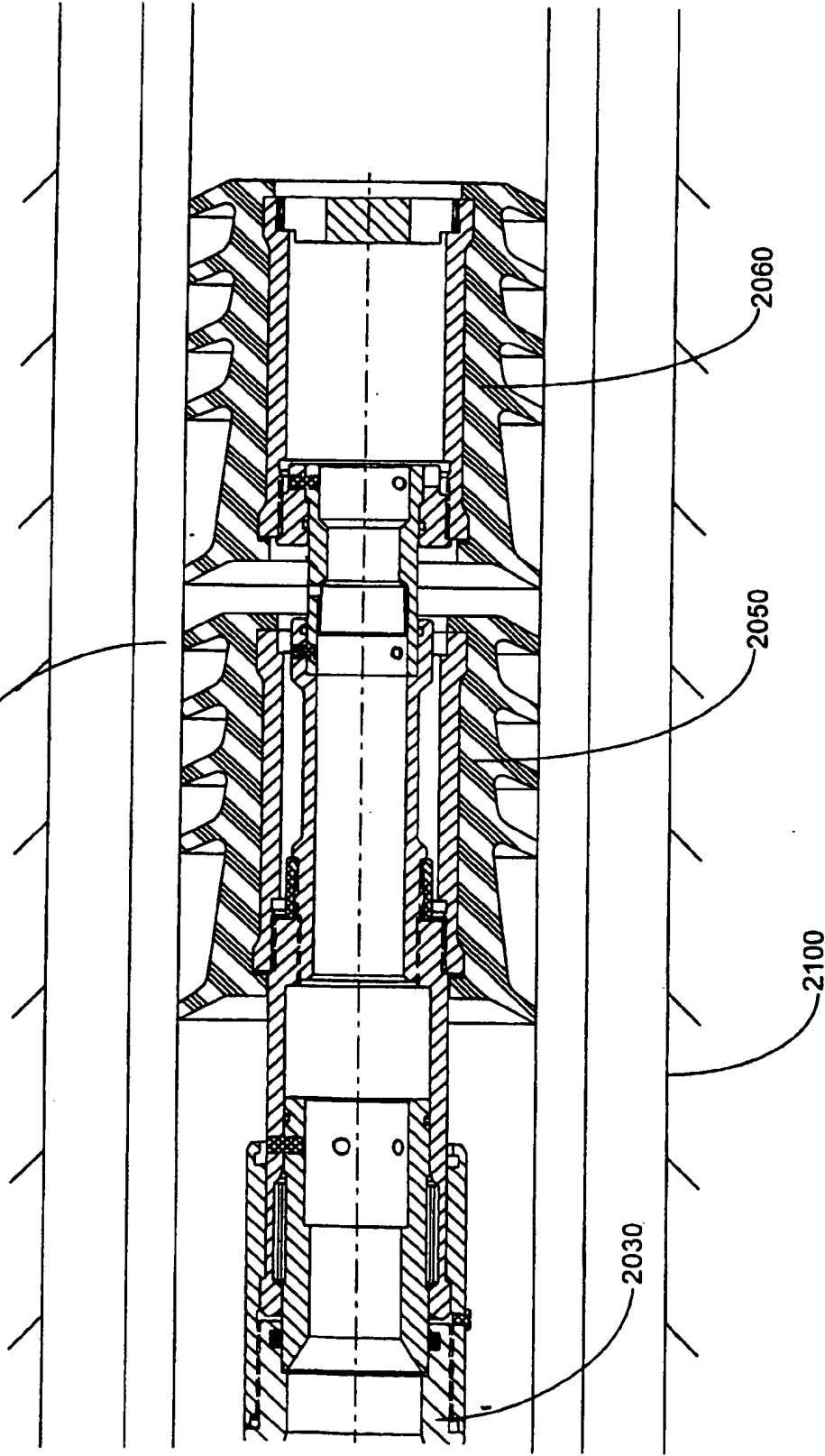

FIGURE 5B

40/79

2070



2060

2050

2100

2030

FIGURE 5C

41/79

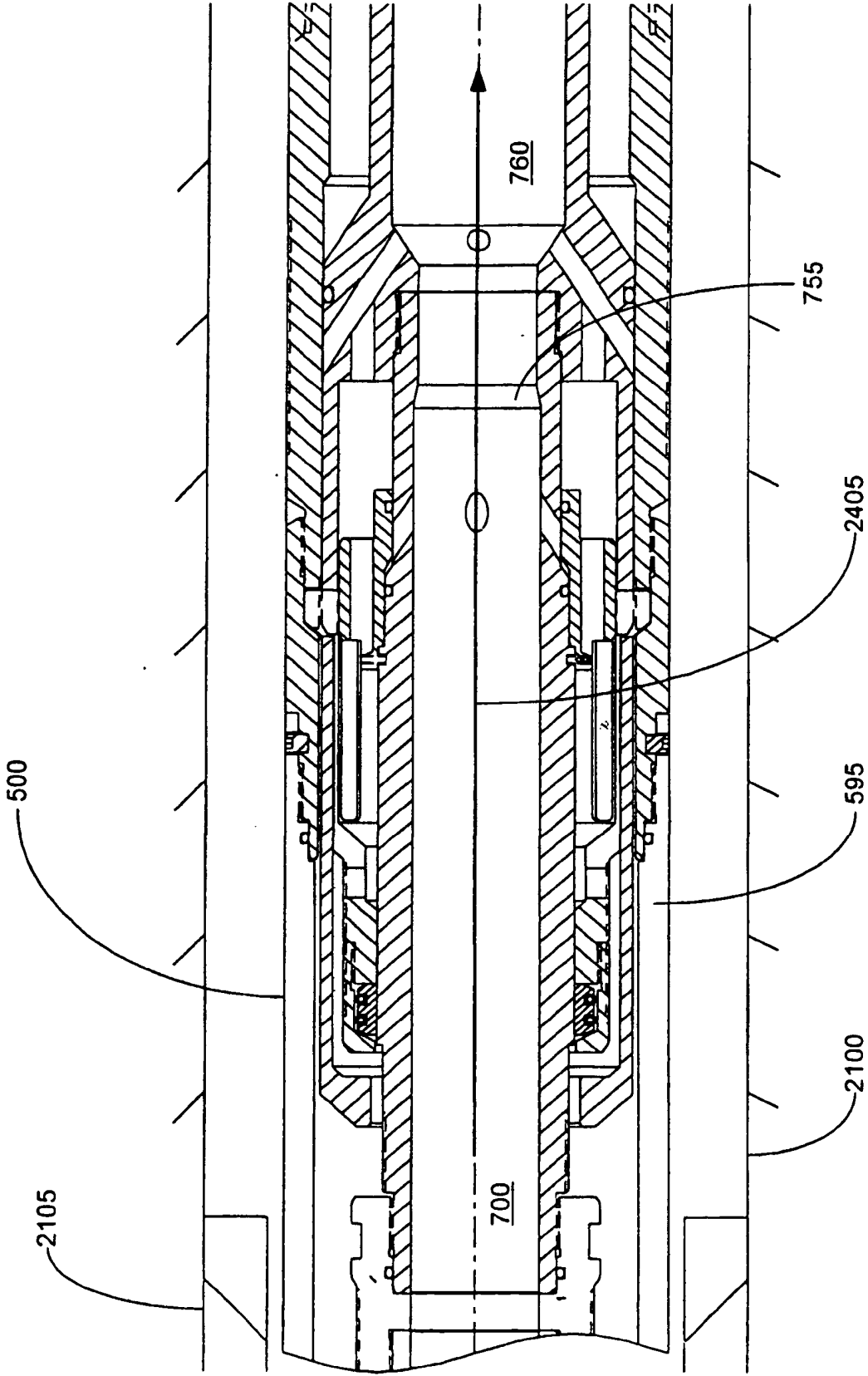

FIGURE 6A

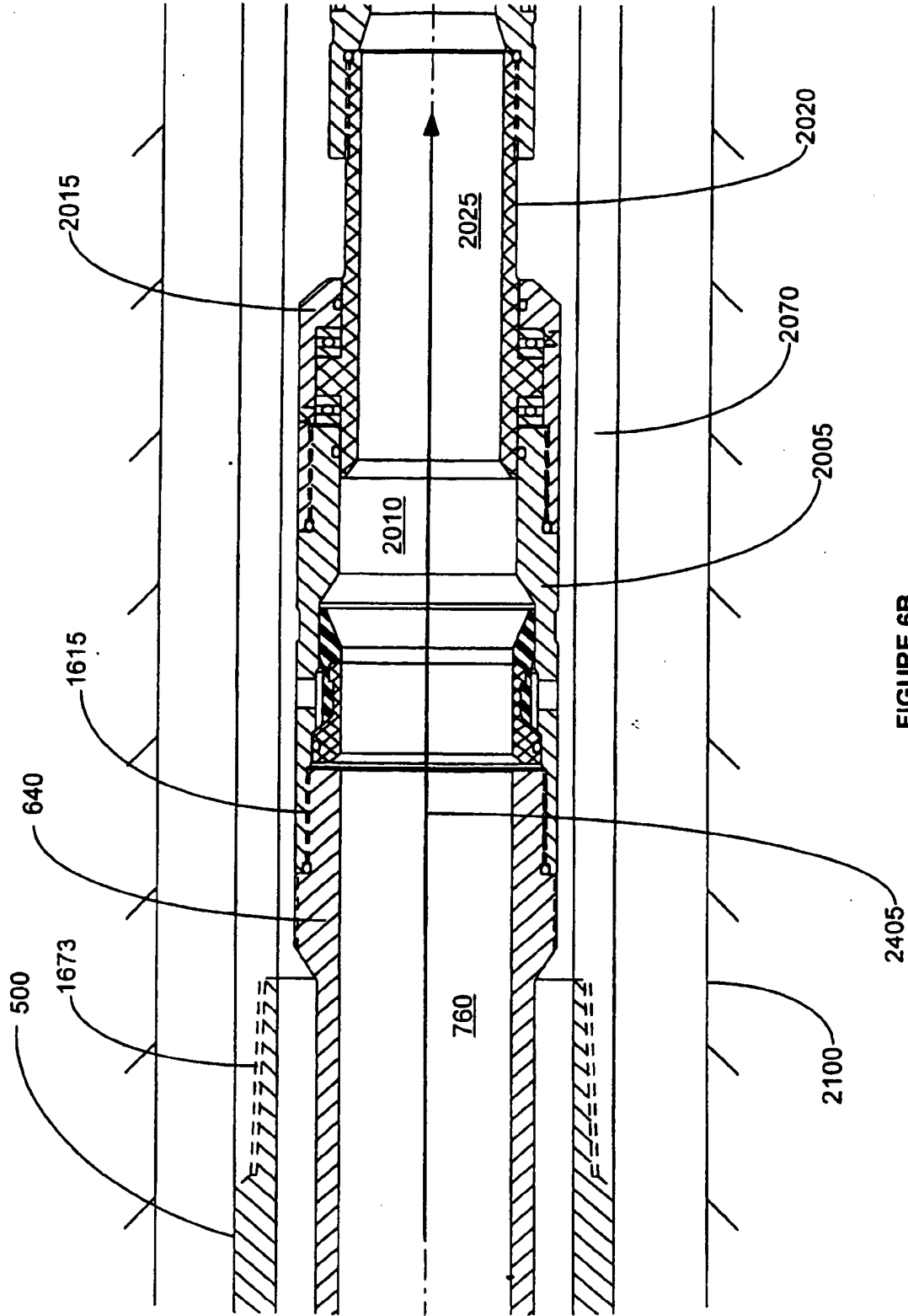

FIGURE 6B

43/79

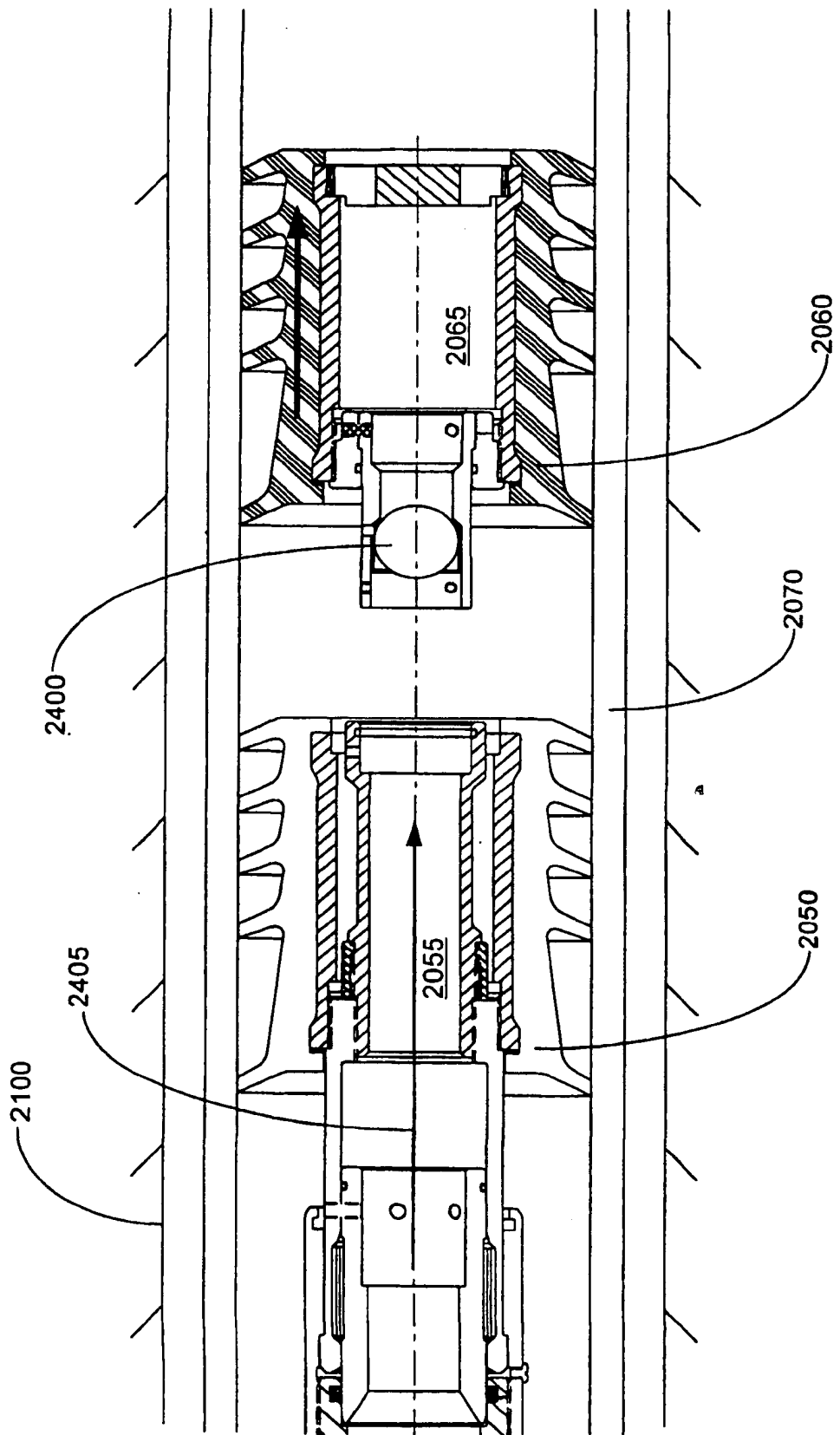

FIGURE 6C

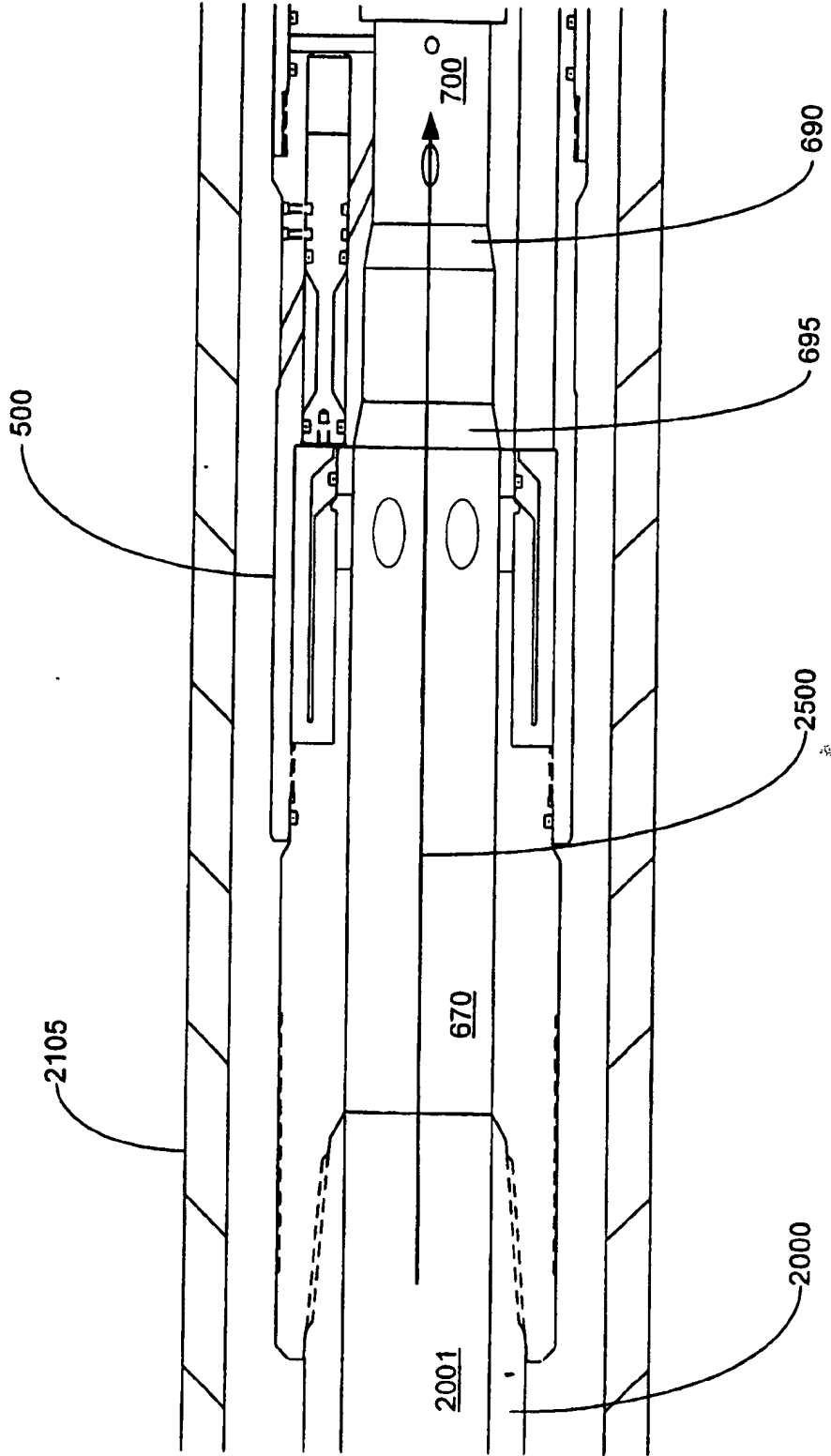

FIGURE 7A

45/79

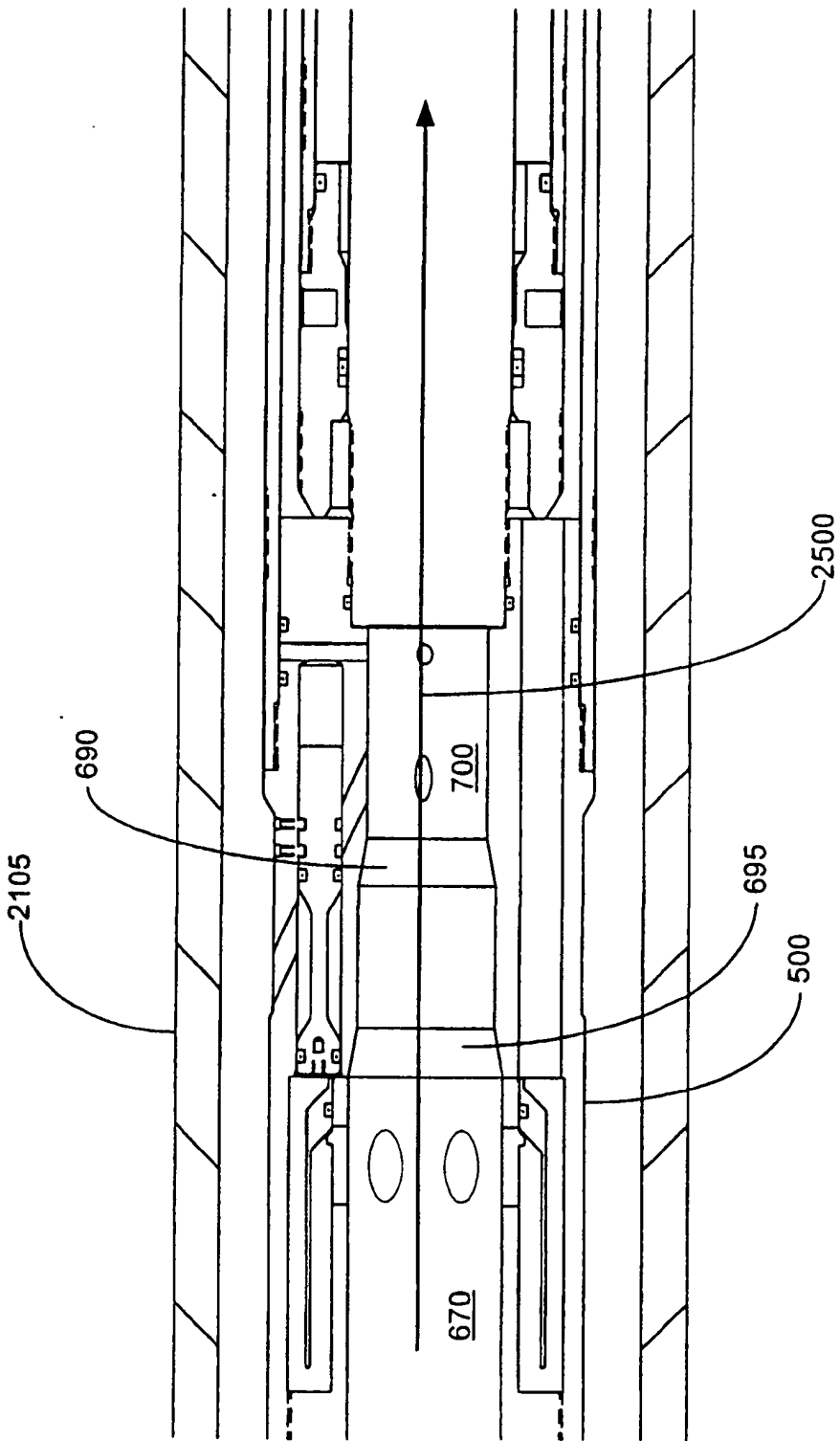

FIGURE 7B

4679

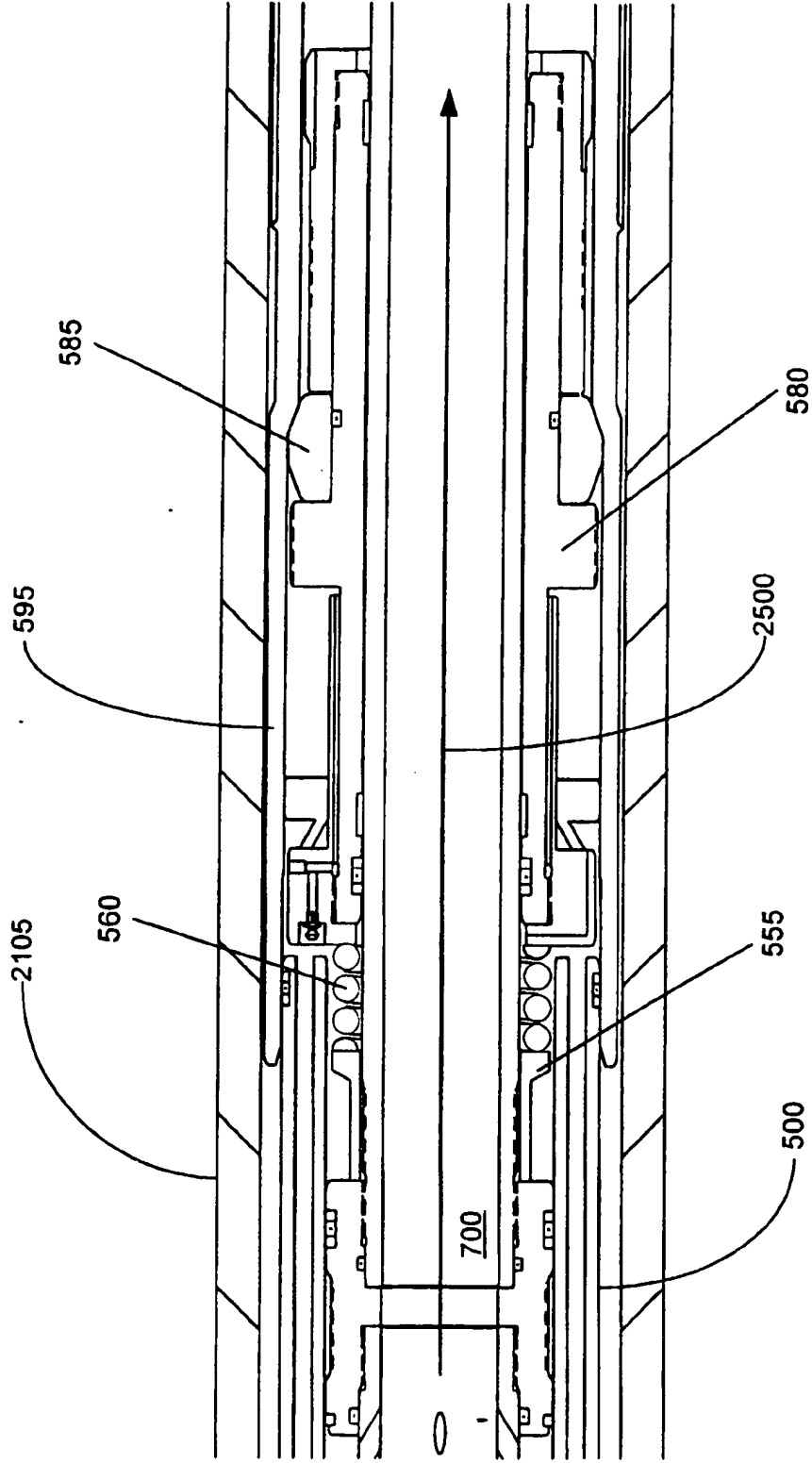

FIGURE 7C

4779

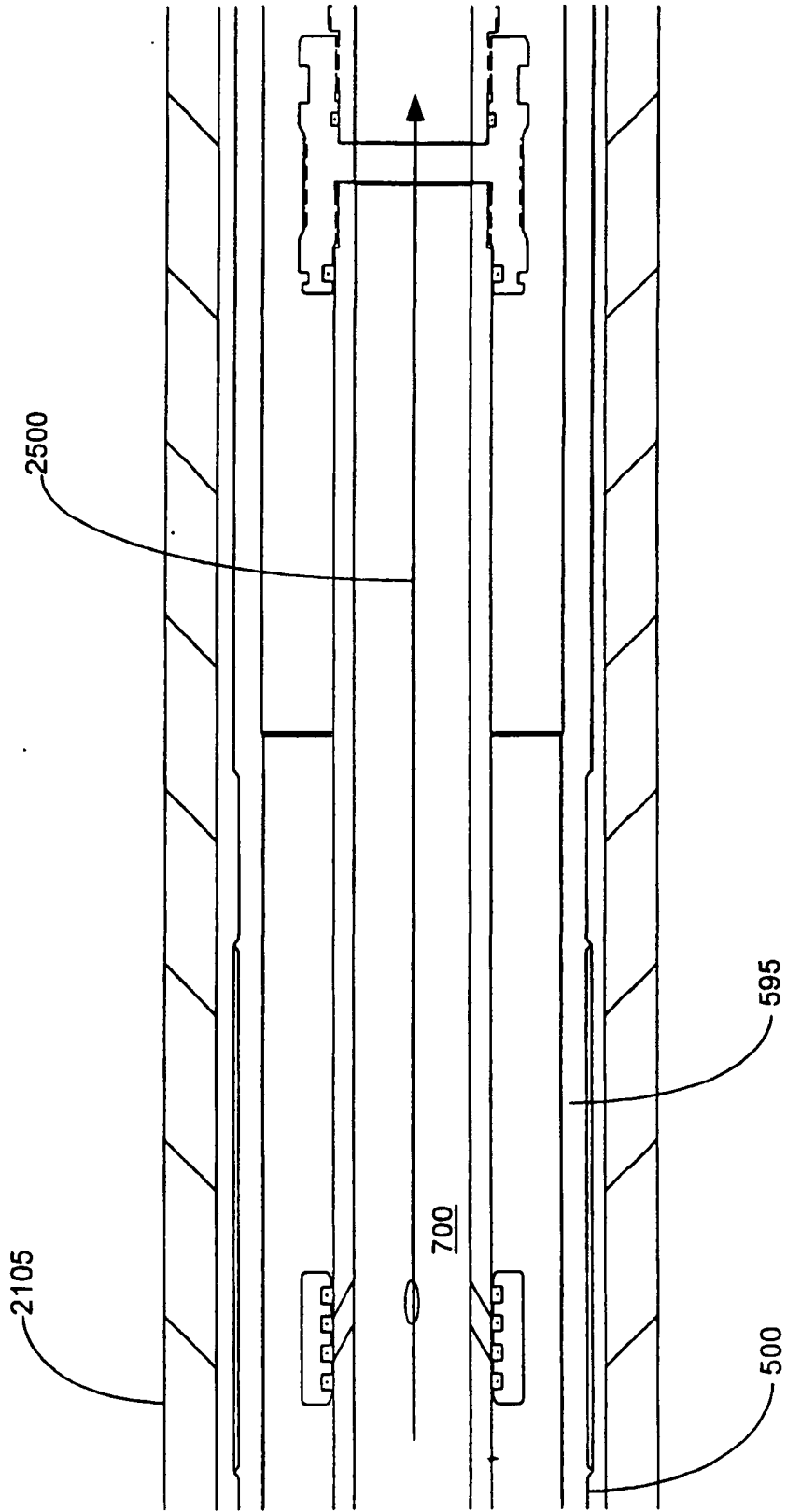

FIGURE 7D

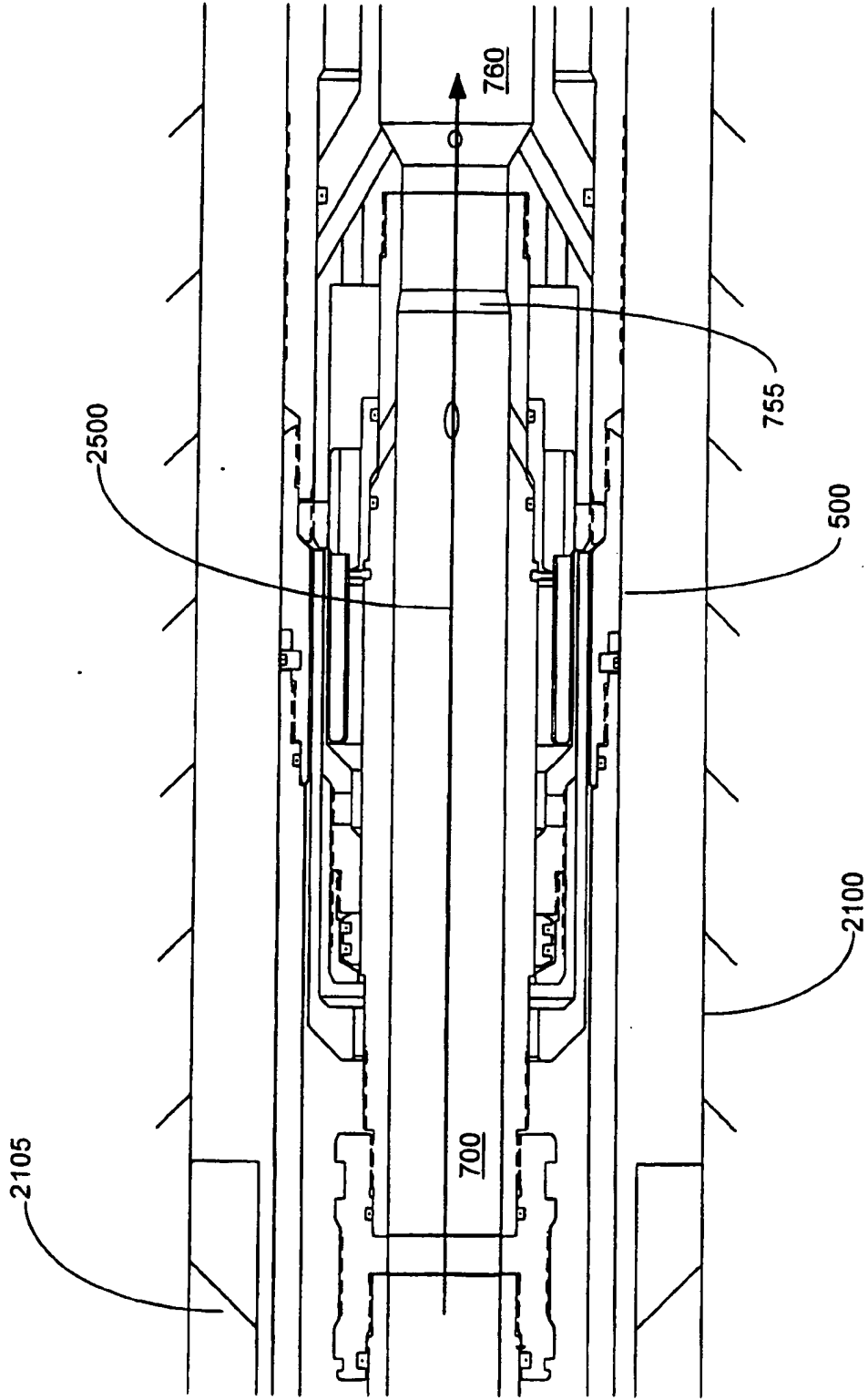

FIGURE 7E

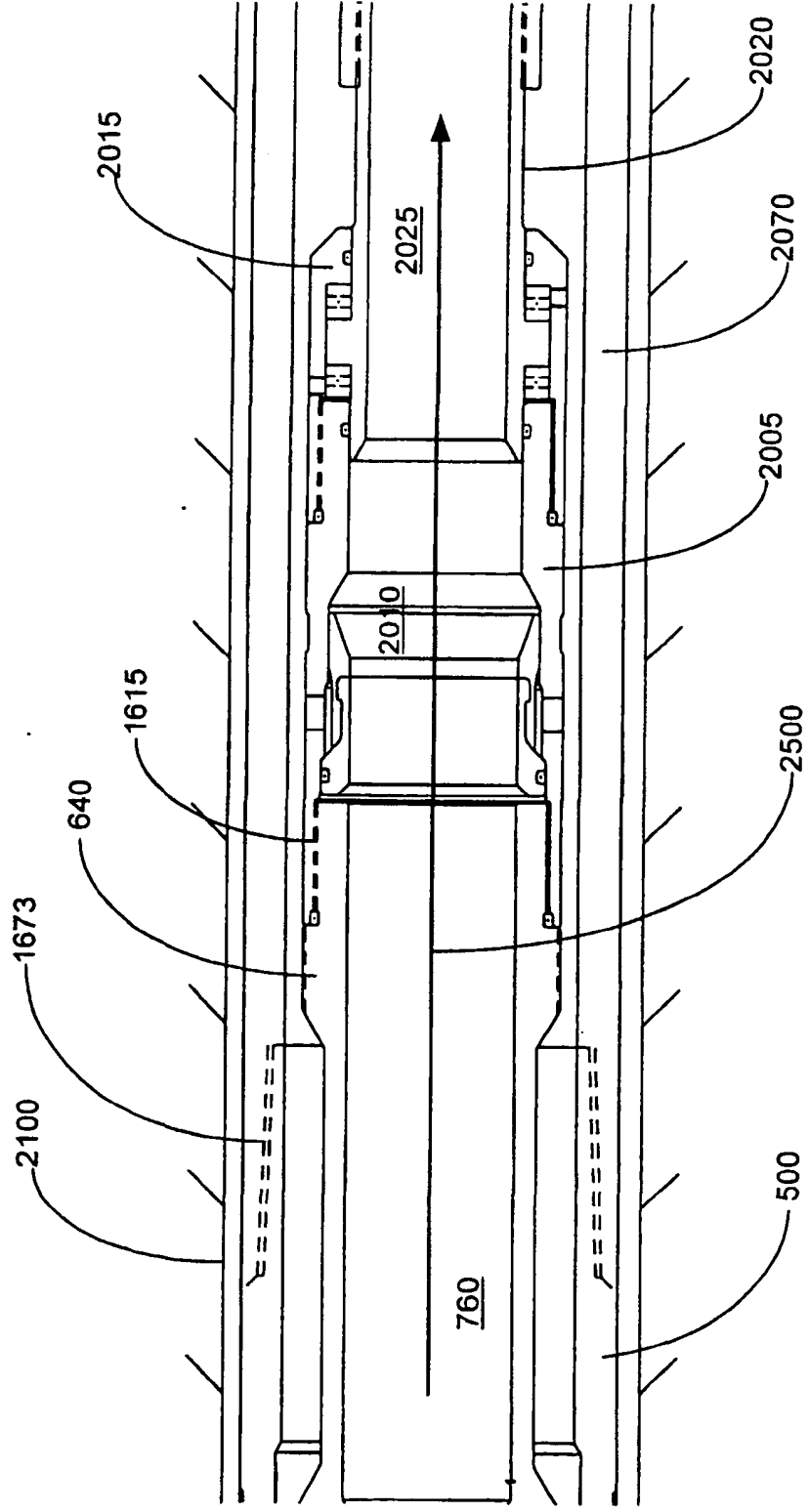

FIGURE 7F

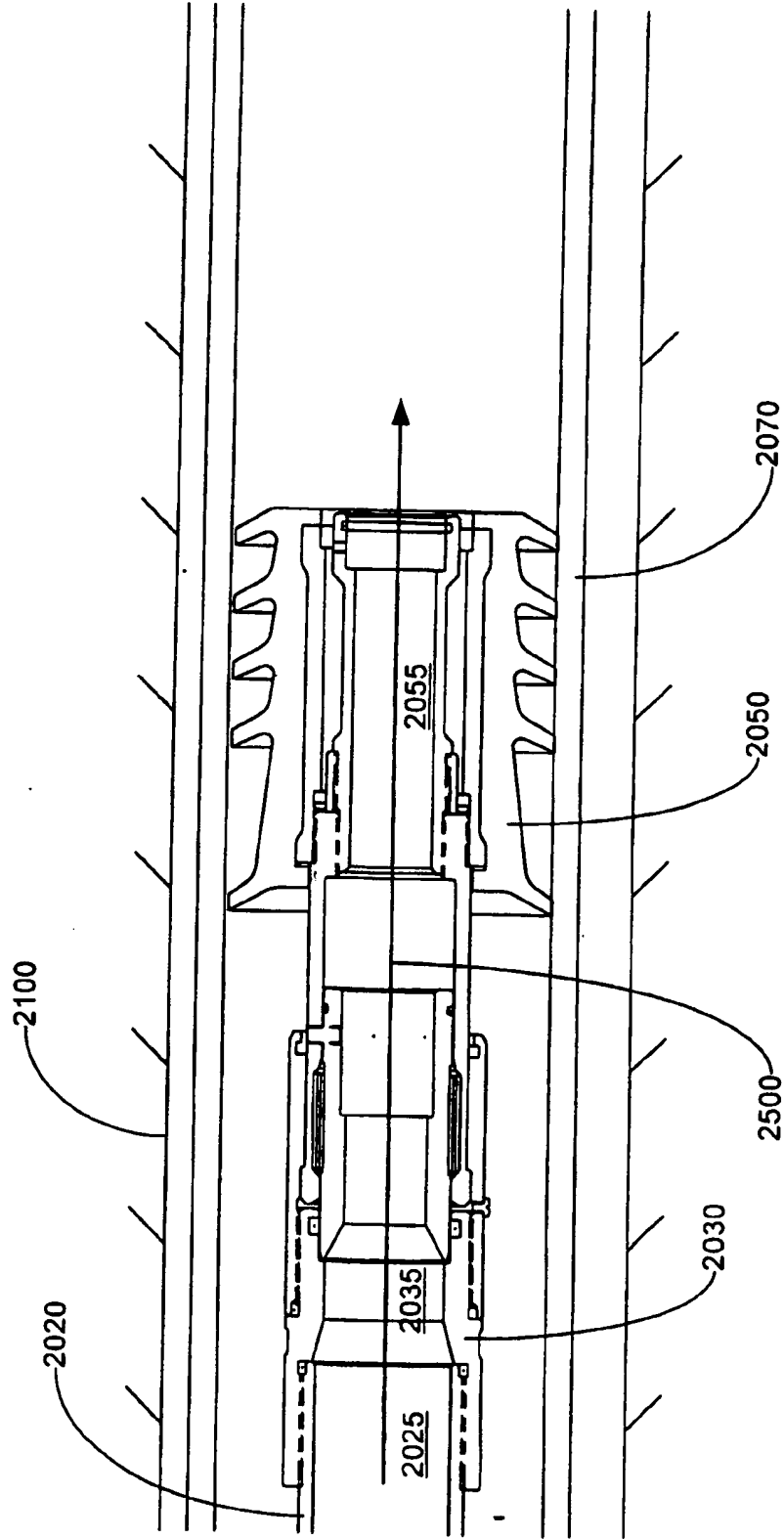

FIGURE 7G

51/79

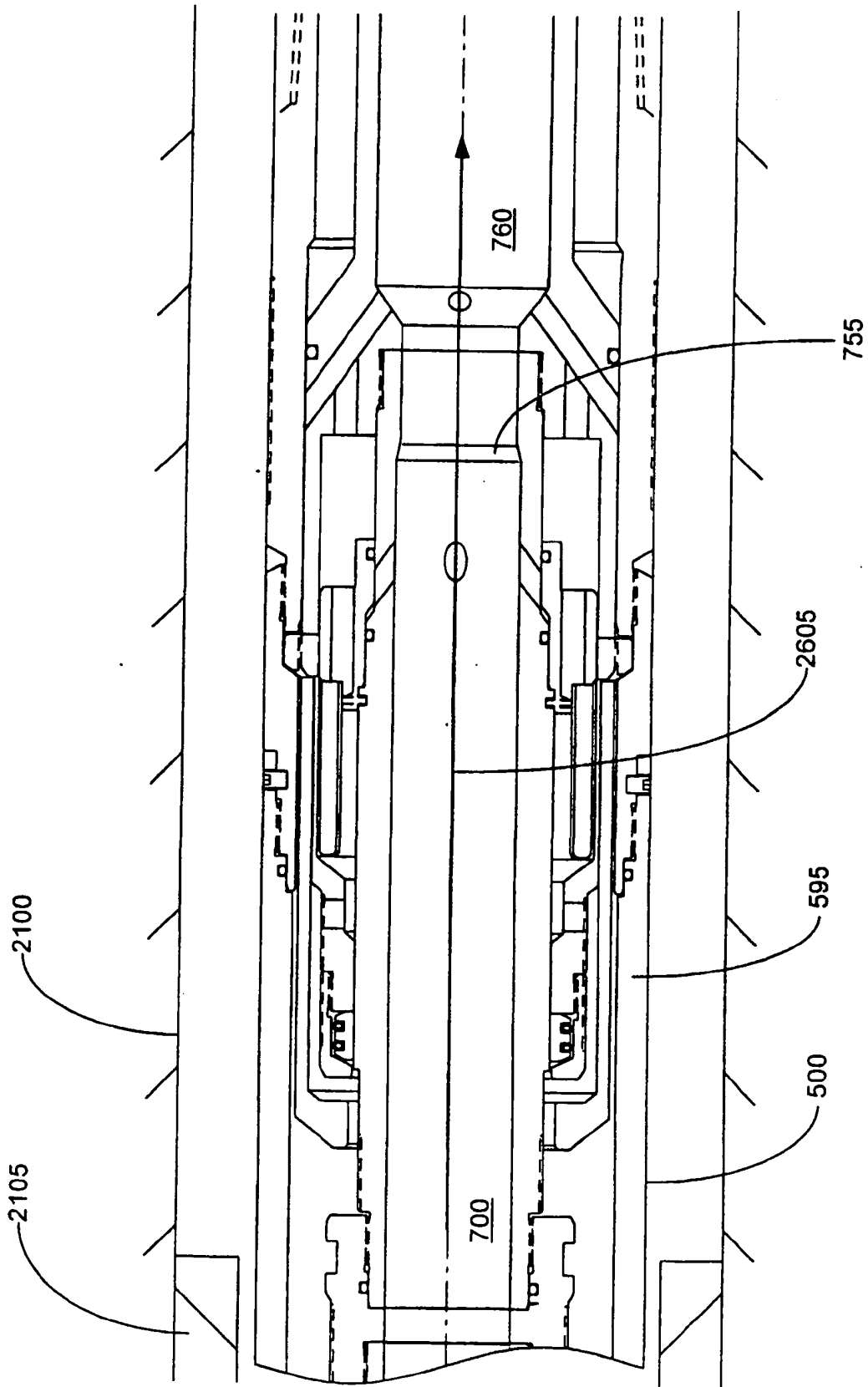

FIGURE 8A

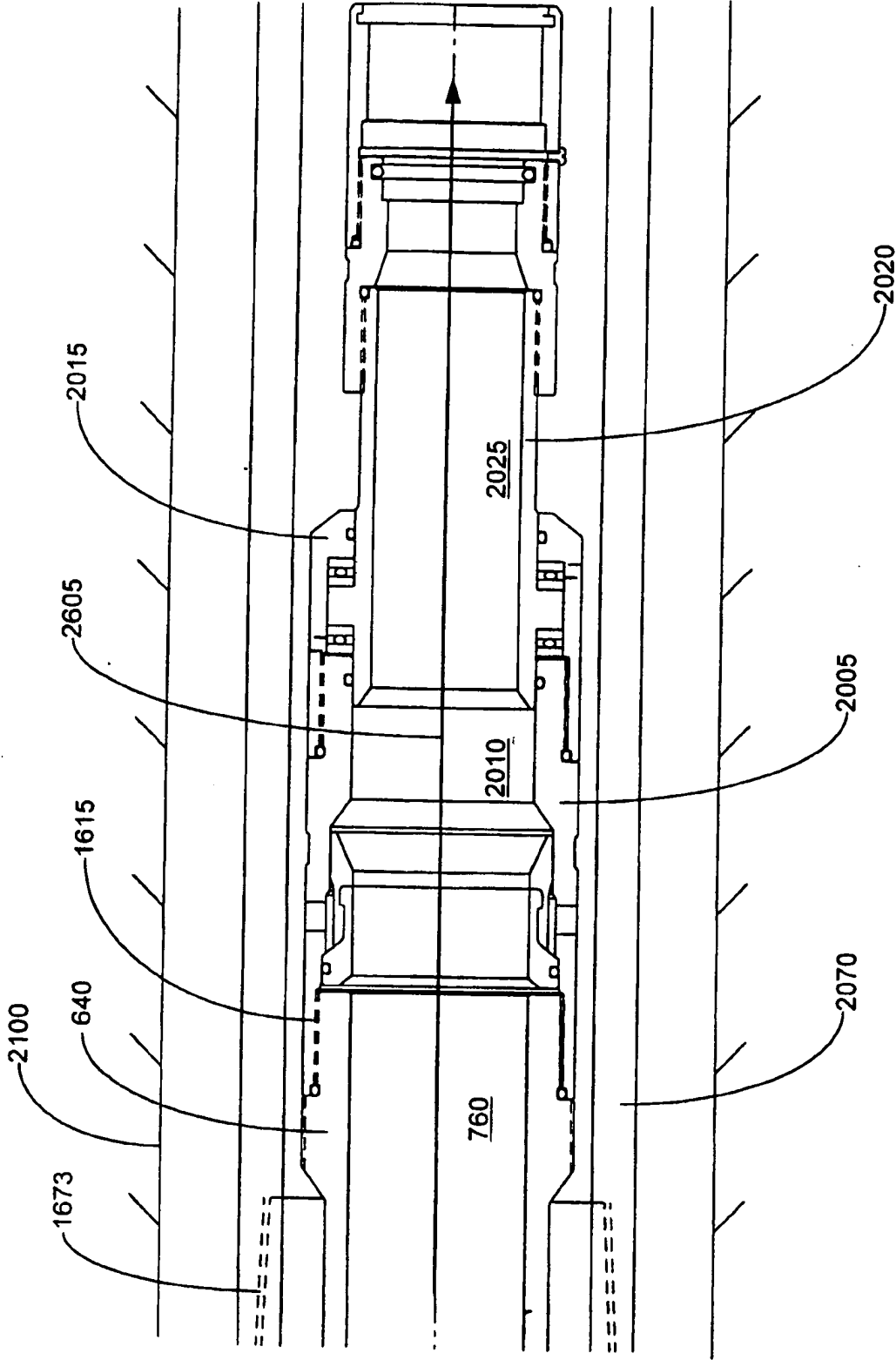

FIGURE 8B

53/79

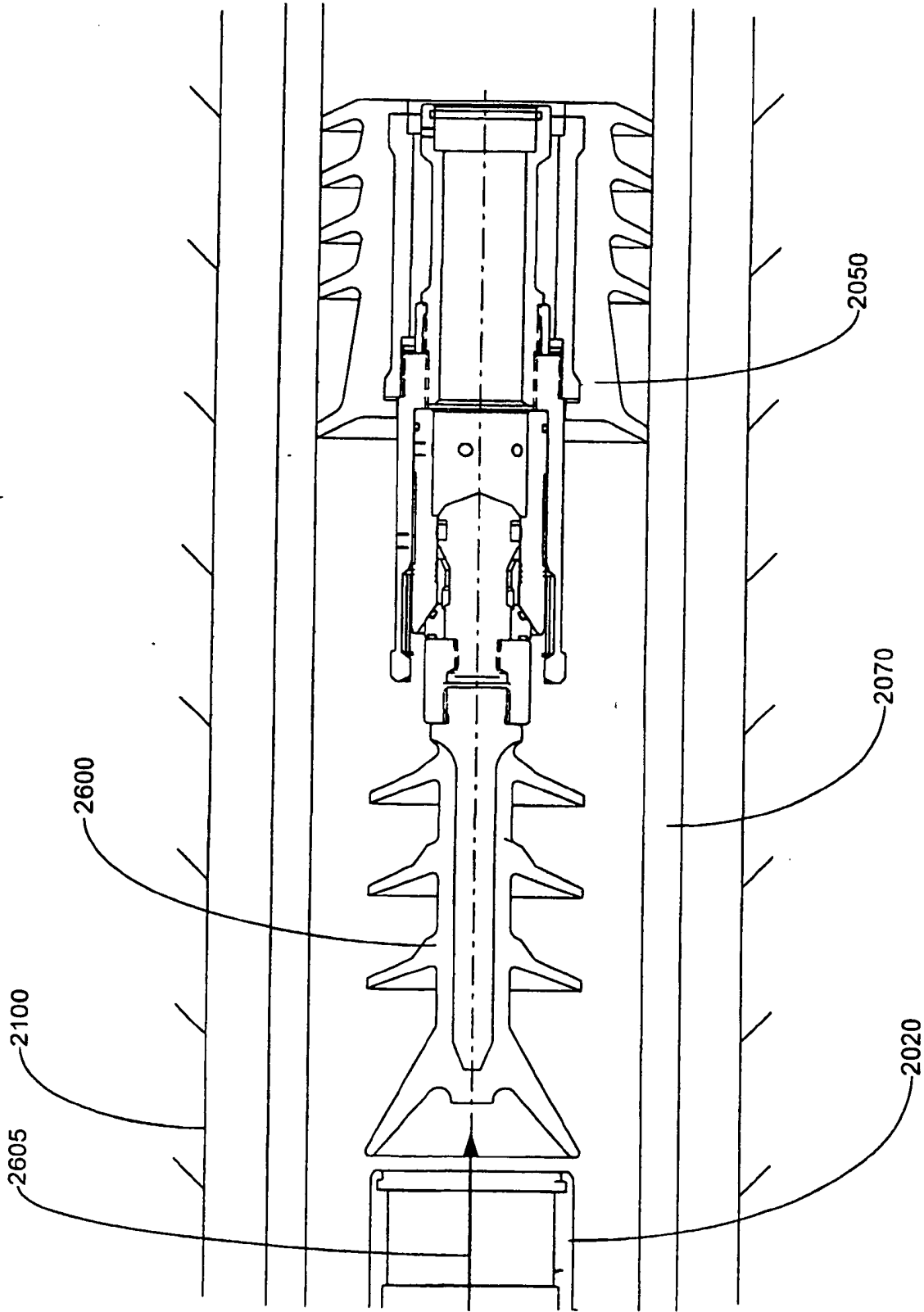

FIGURE 8C

54/79

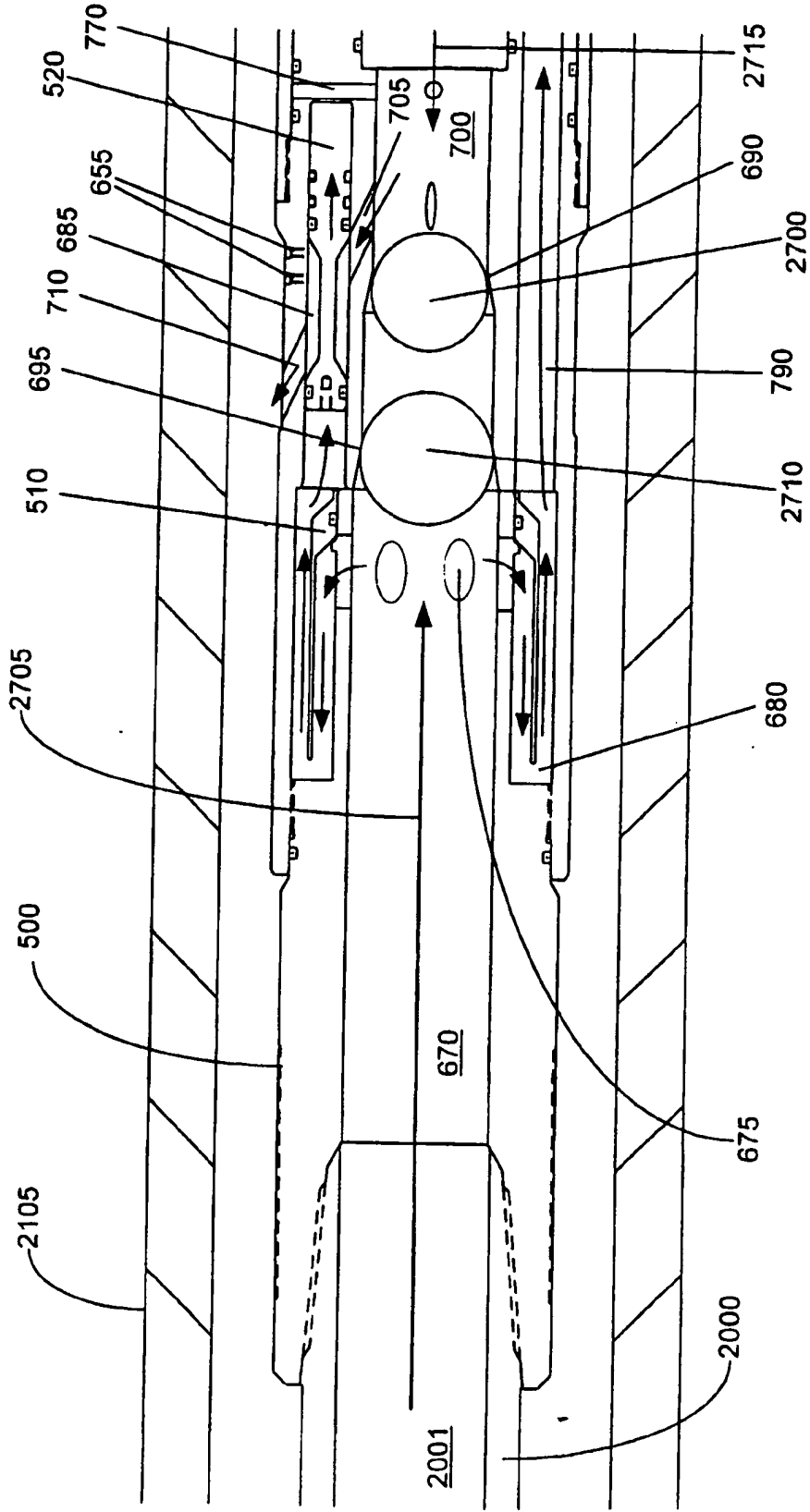

FIGURE 9A

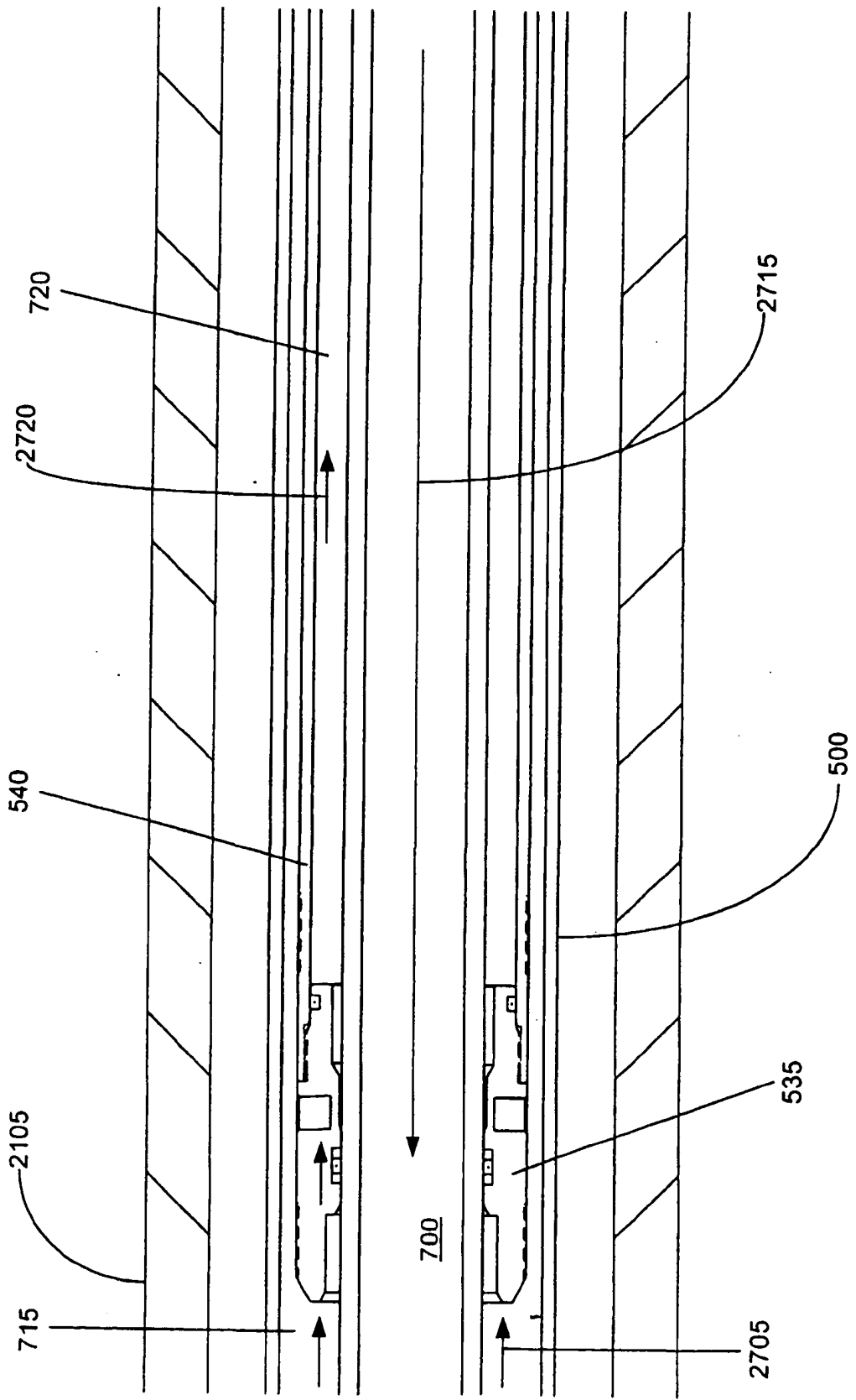

FIGURE 9B

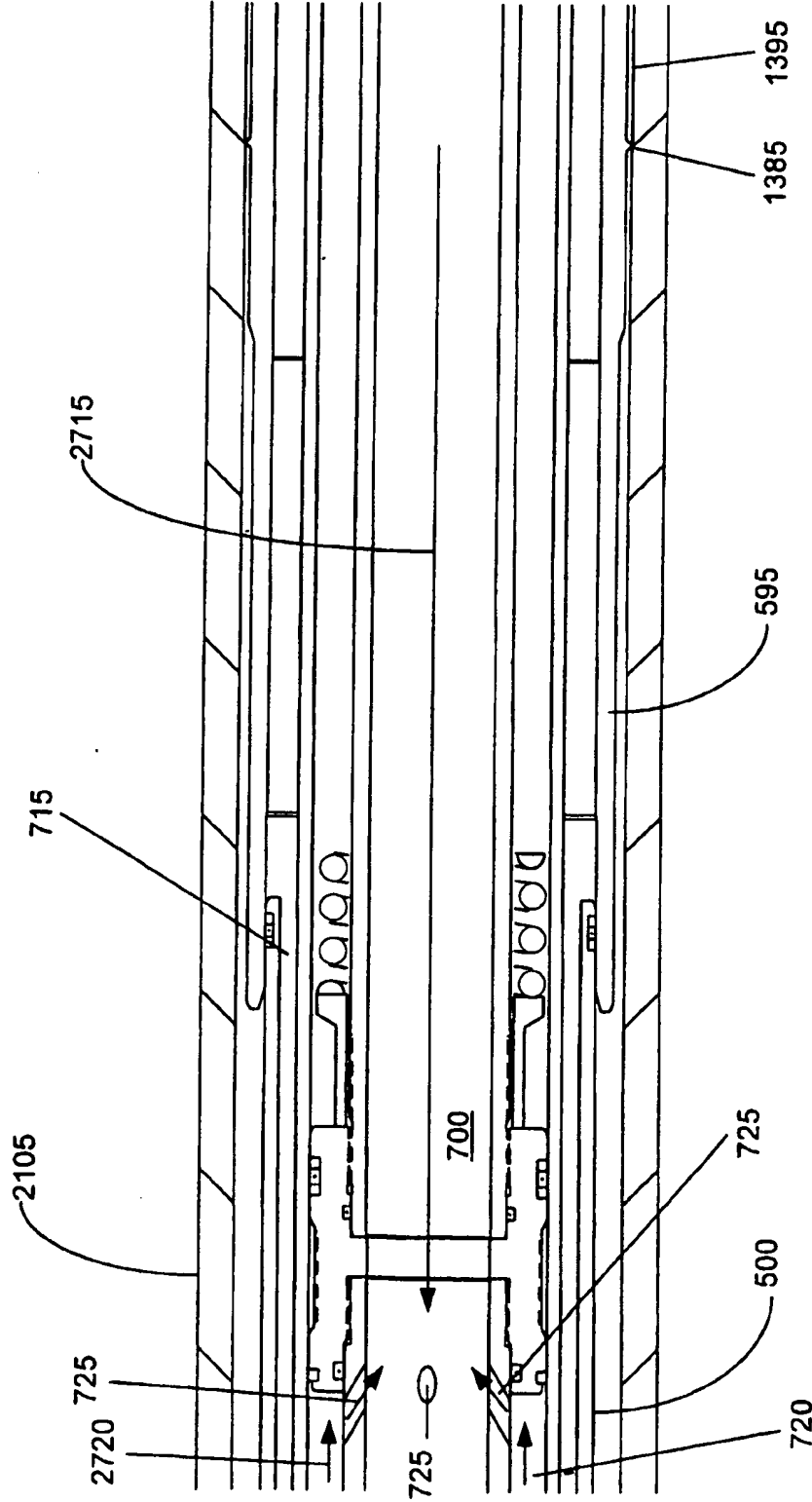

FIGURE 9C

5779

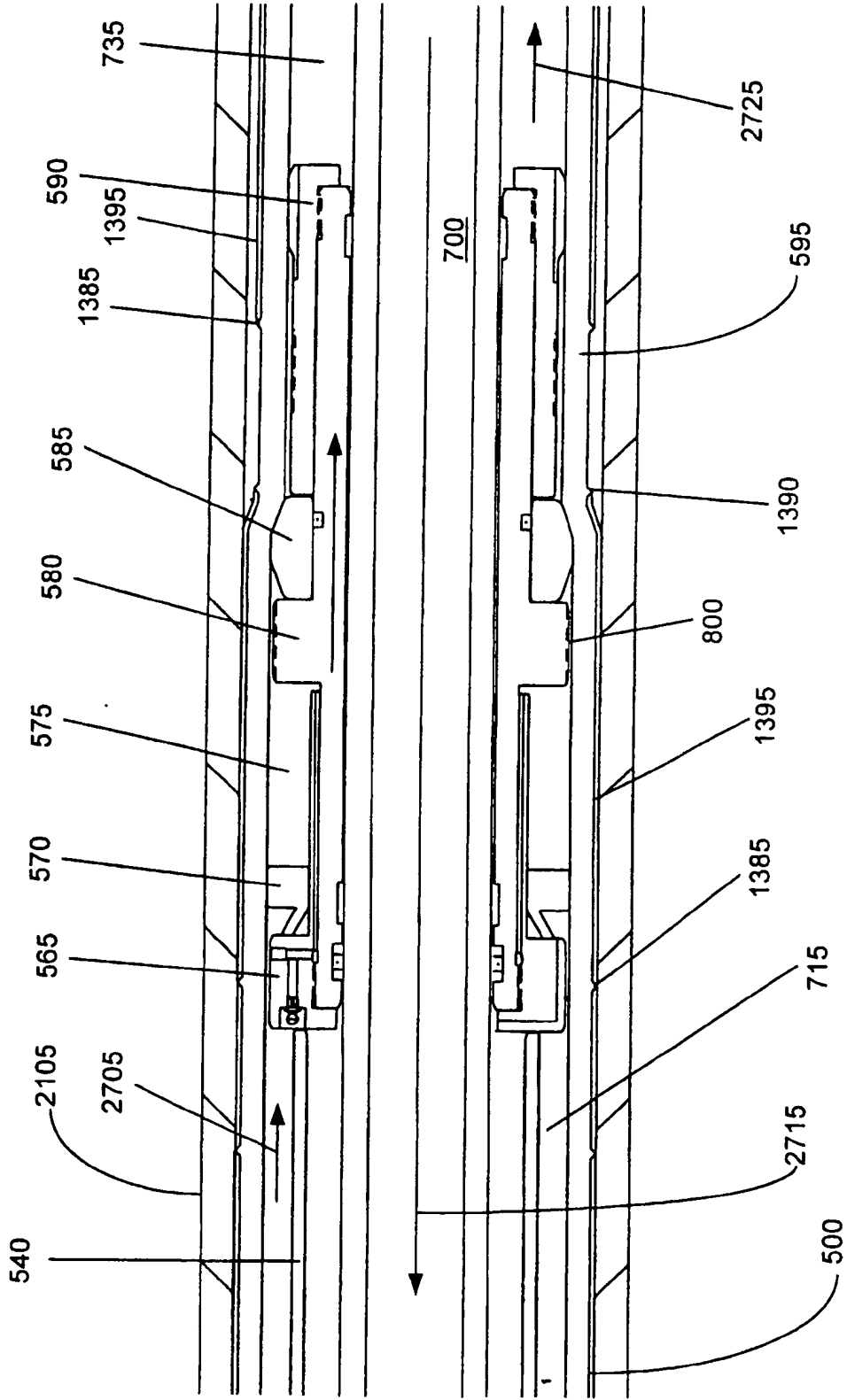

FIGURE 9D

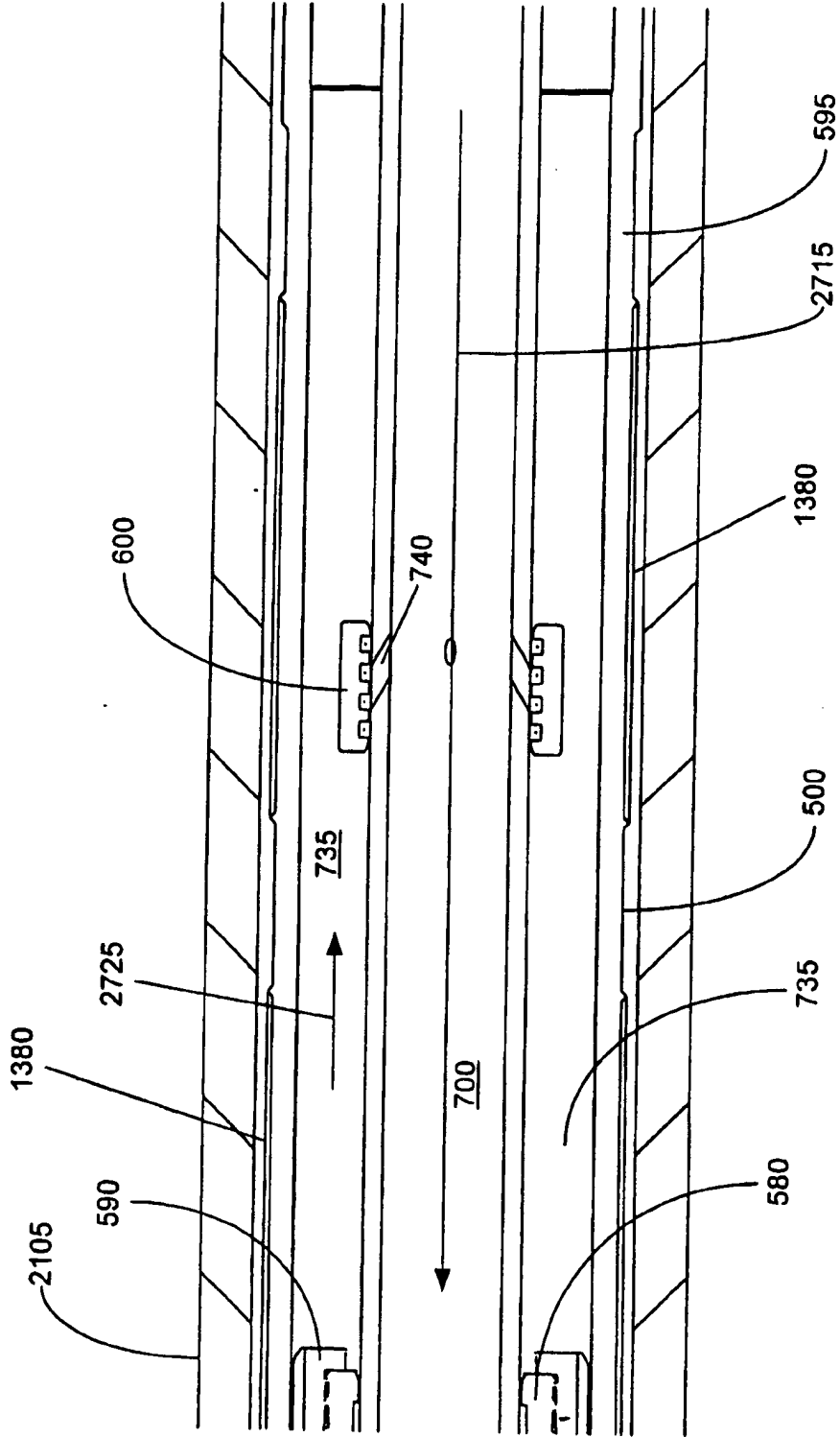

FIGURE 9E

59/79

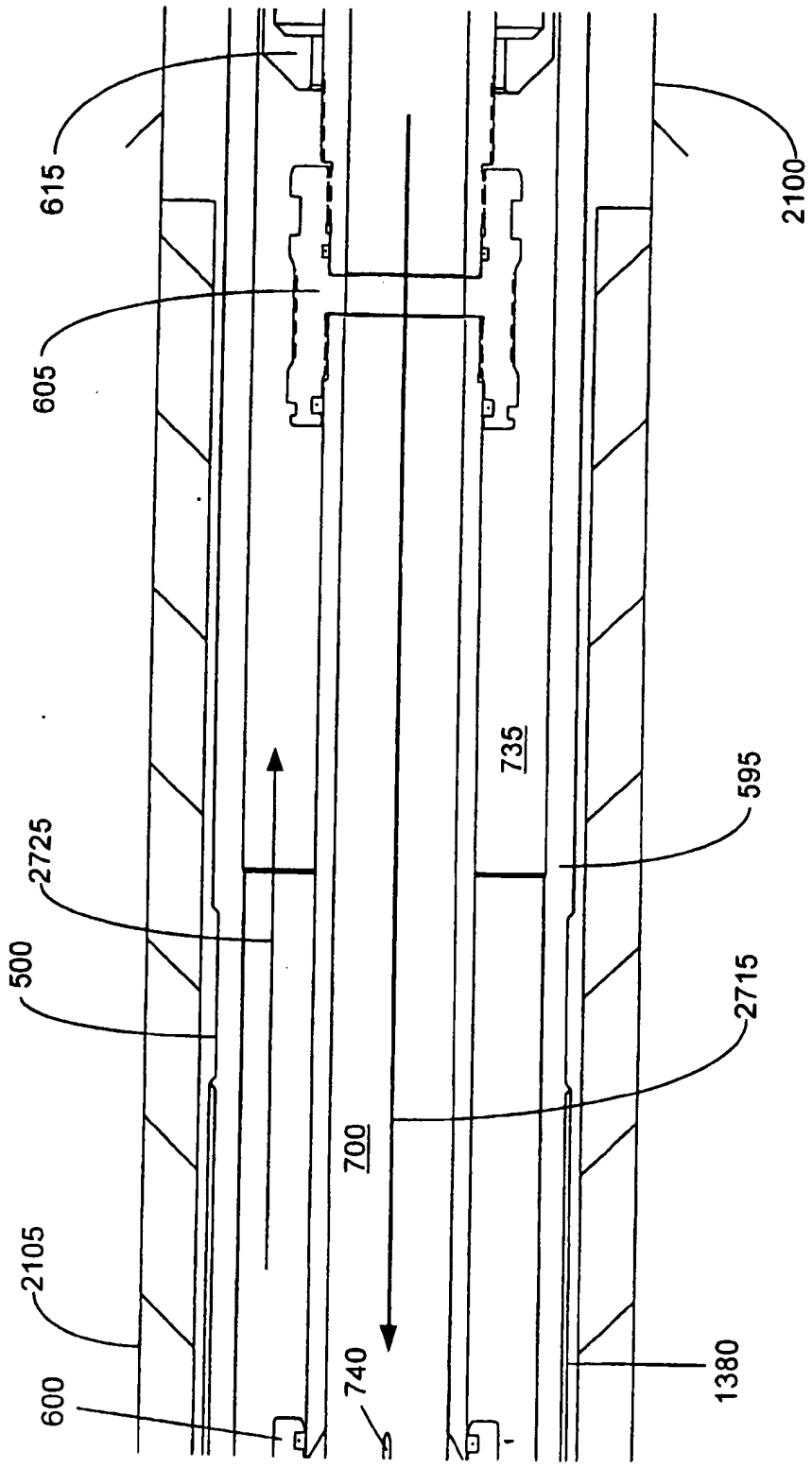

FIGURE 9F

6079

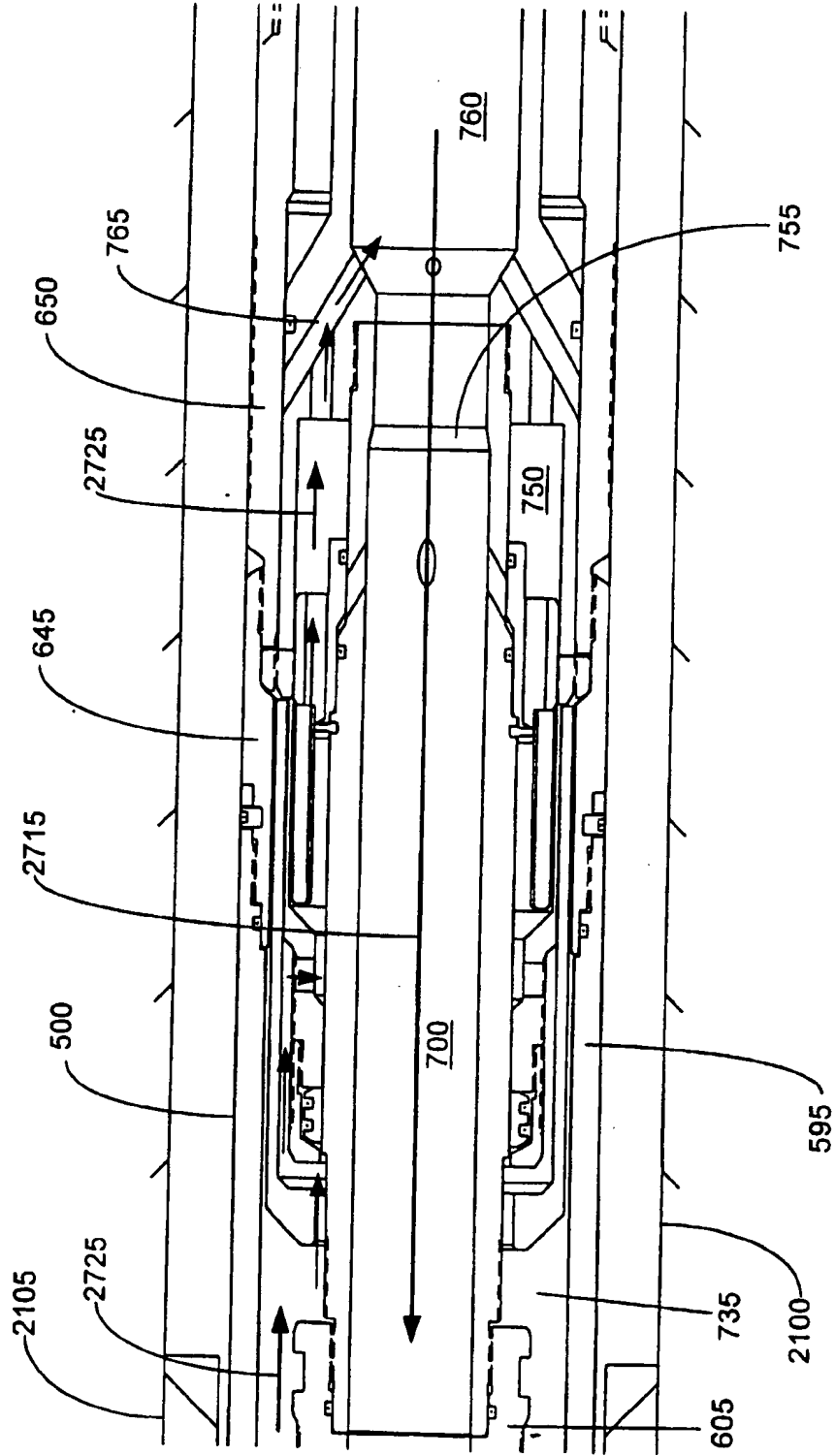

FIGURE 9G

61/79

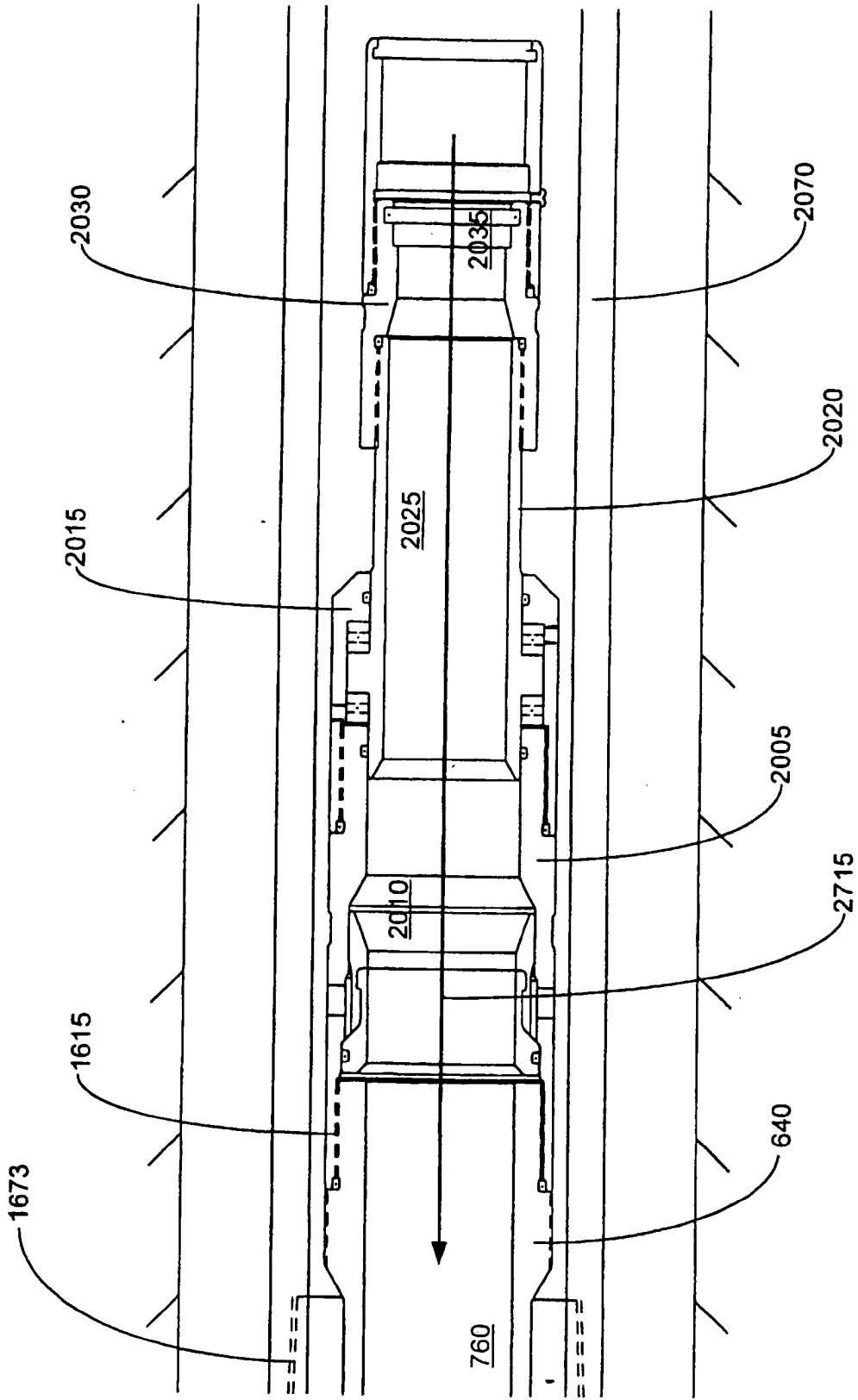

FIGURE 9H

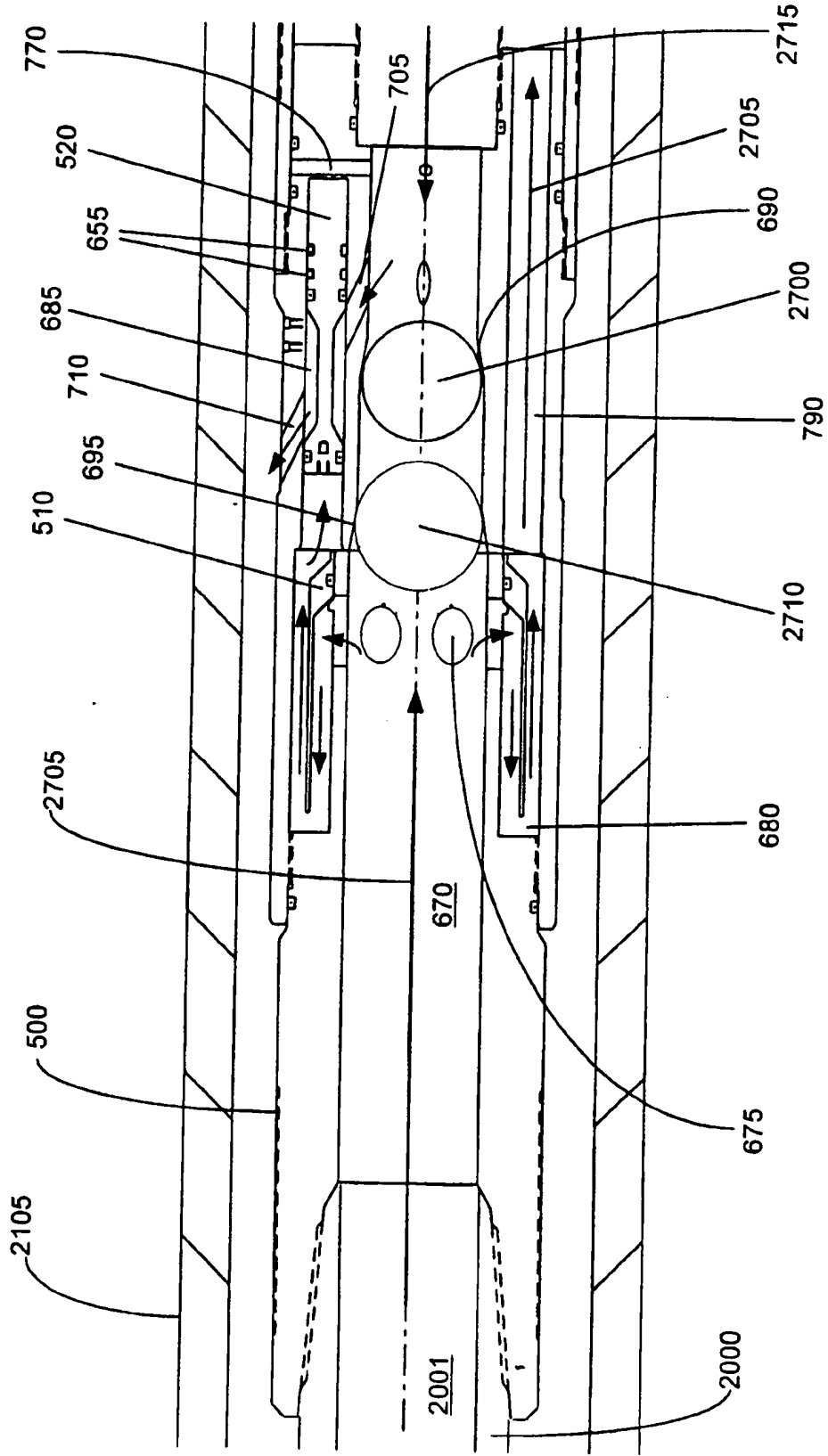

FIGURE 10A

63/79

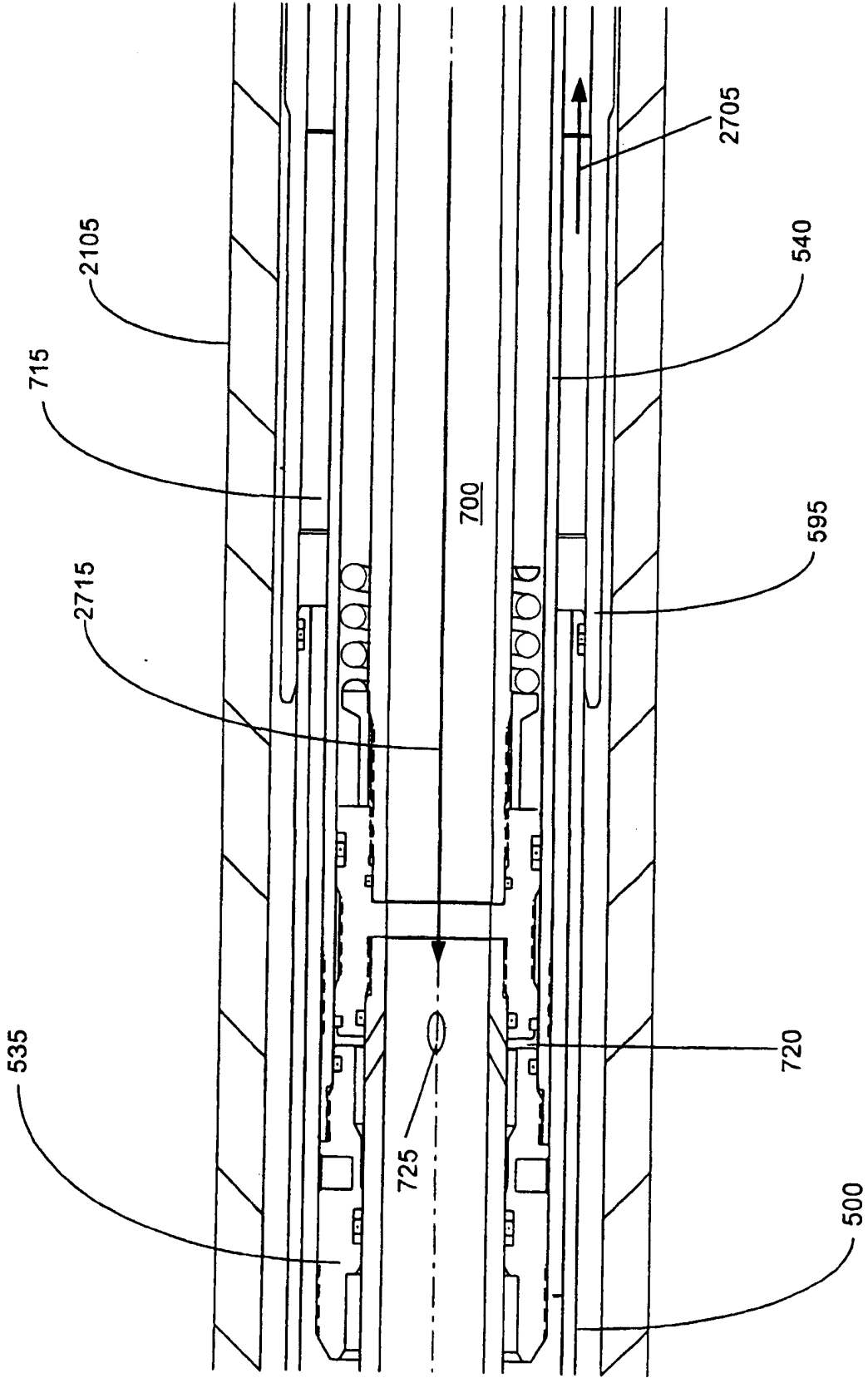

FIGURE 10B

6479

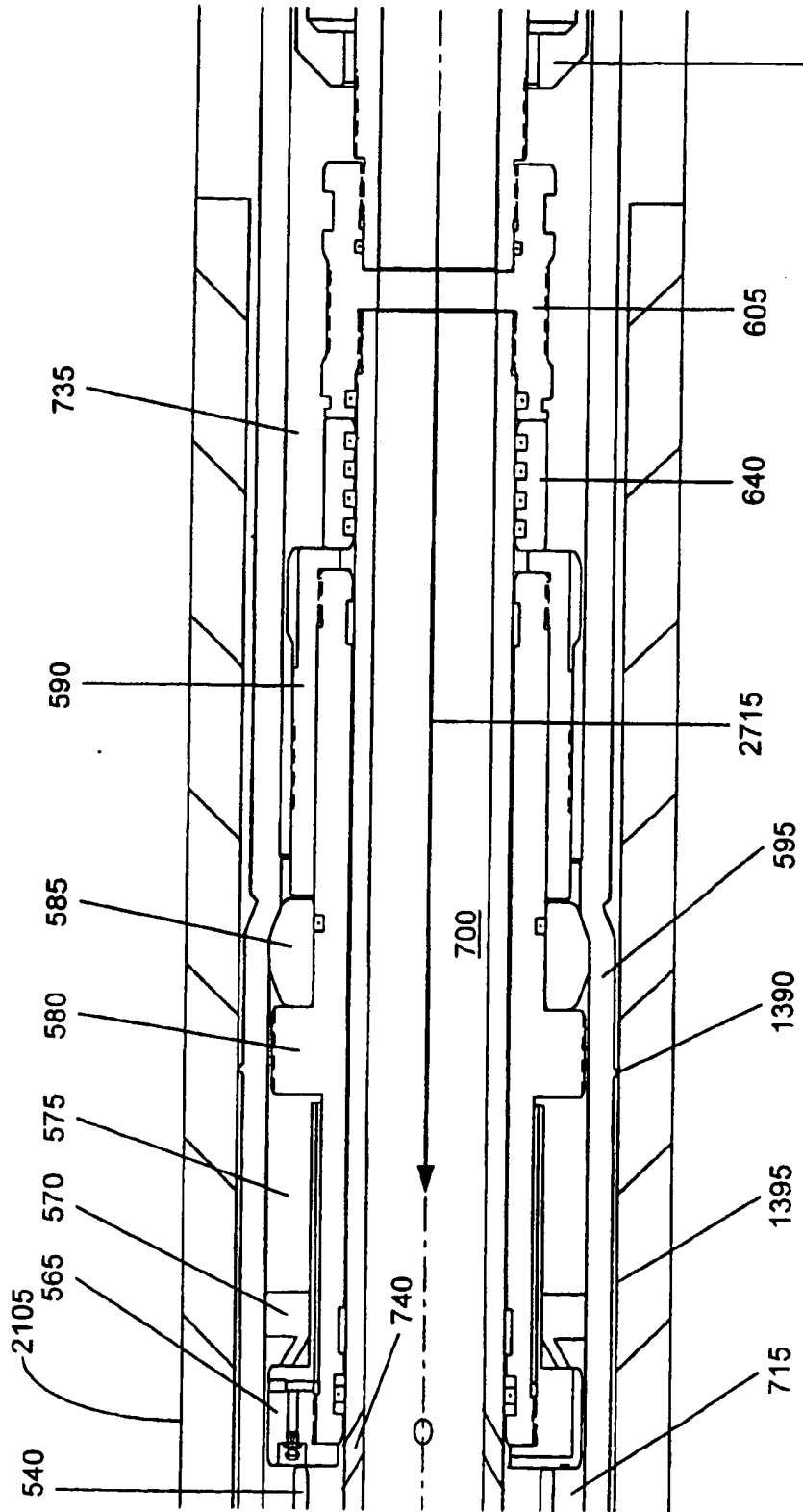

FIGURE 10C

65/79

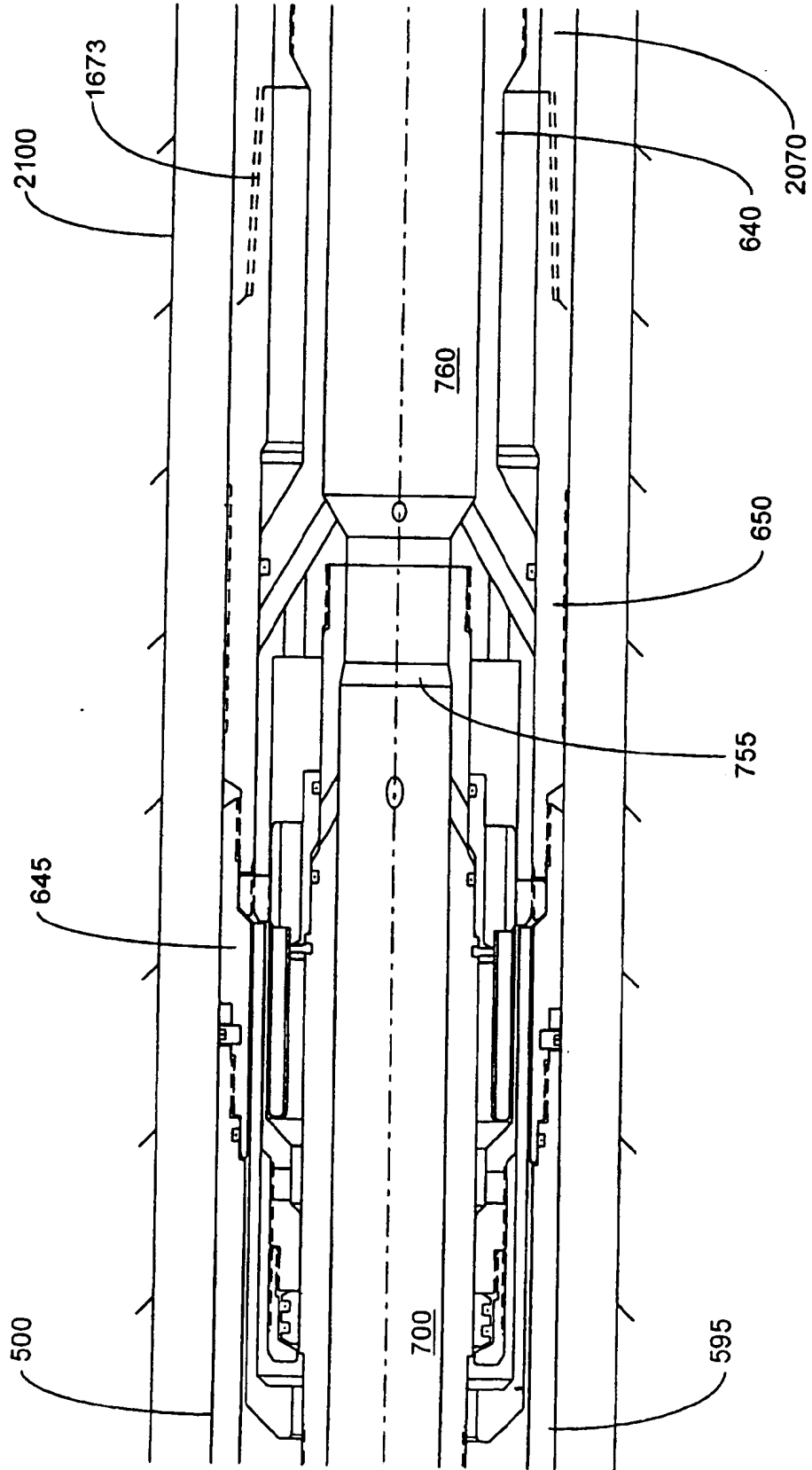

FIGURE 10D

6679

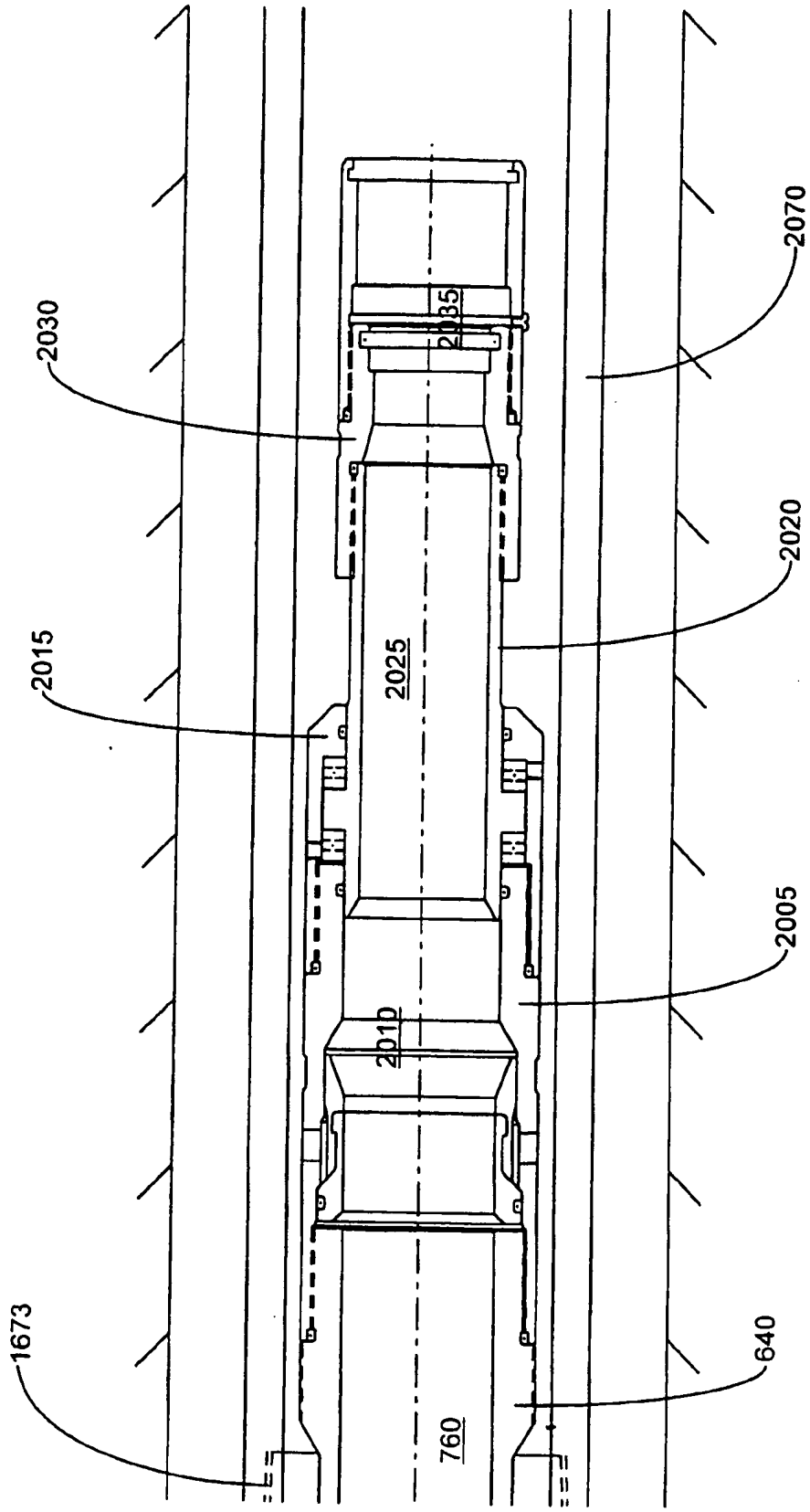

FIGURE 10E

67179

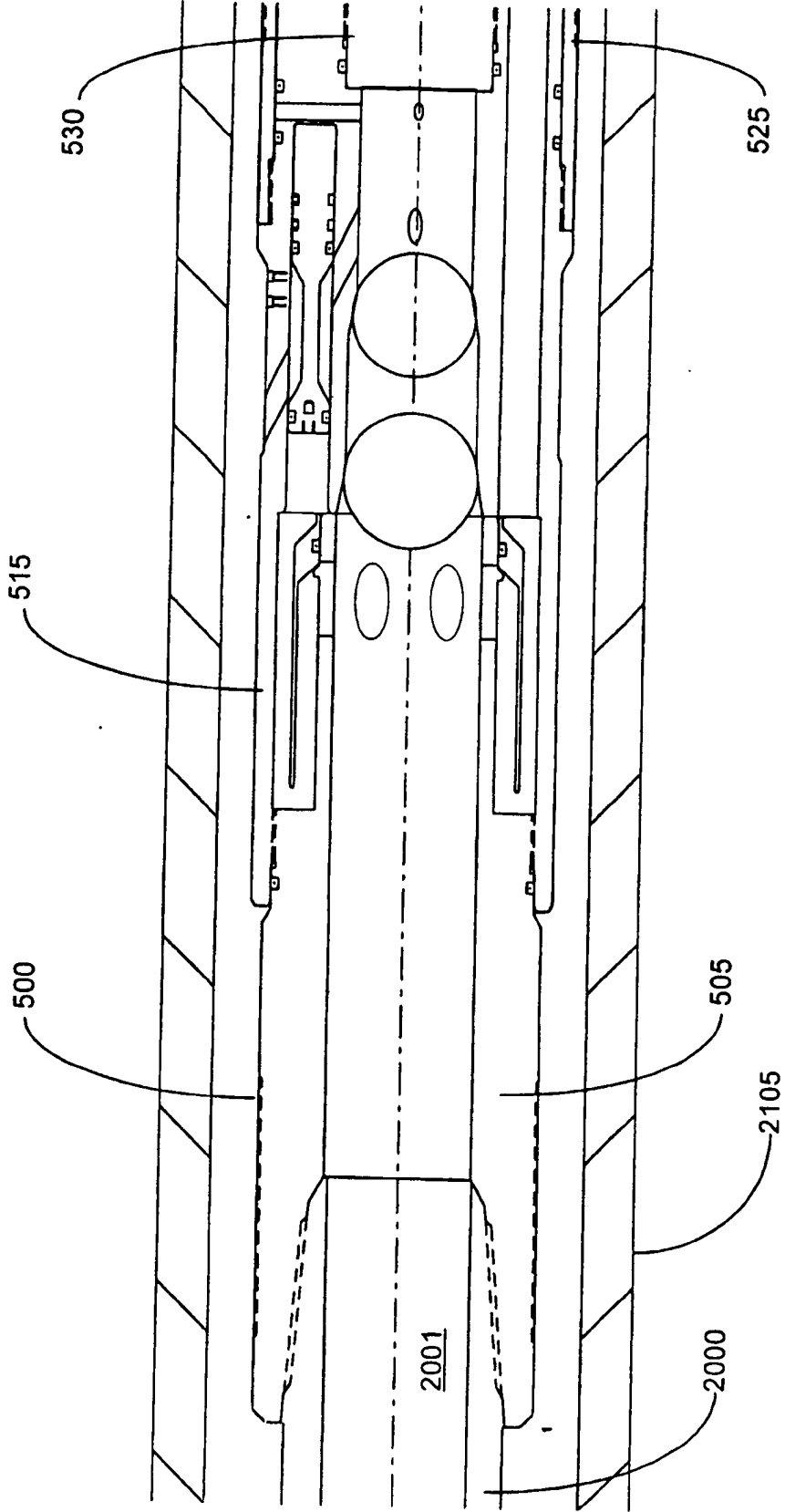

FIGURE 11A

68/79

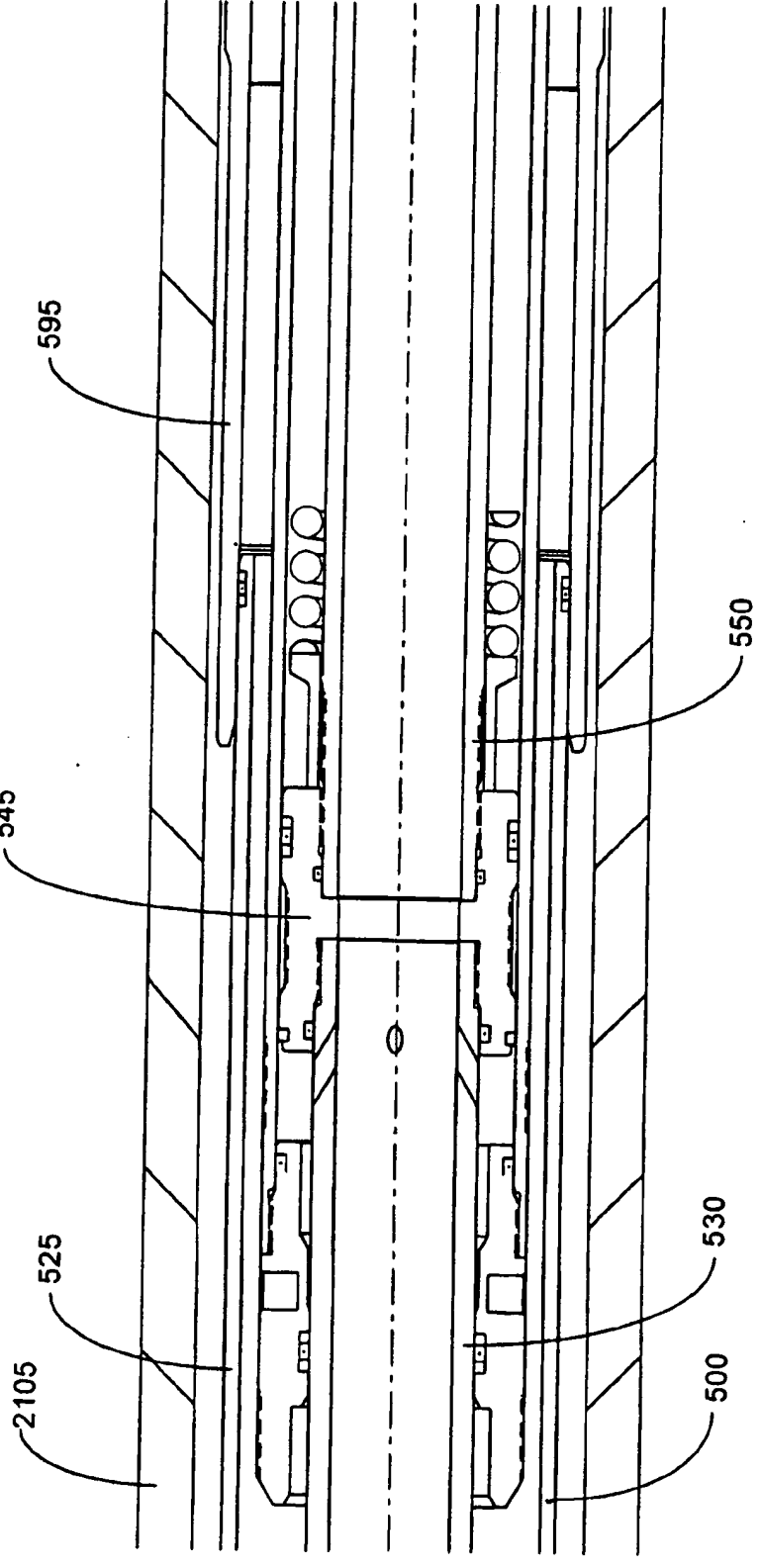

FIGURE 11B

69/79

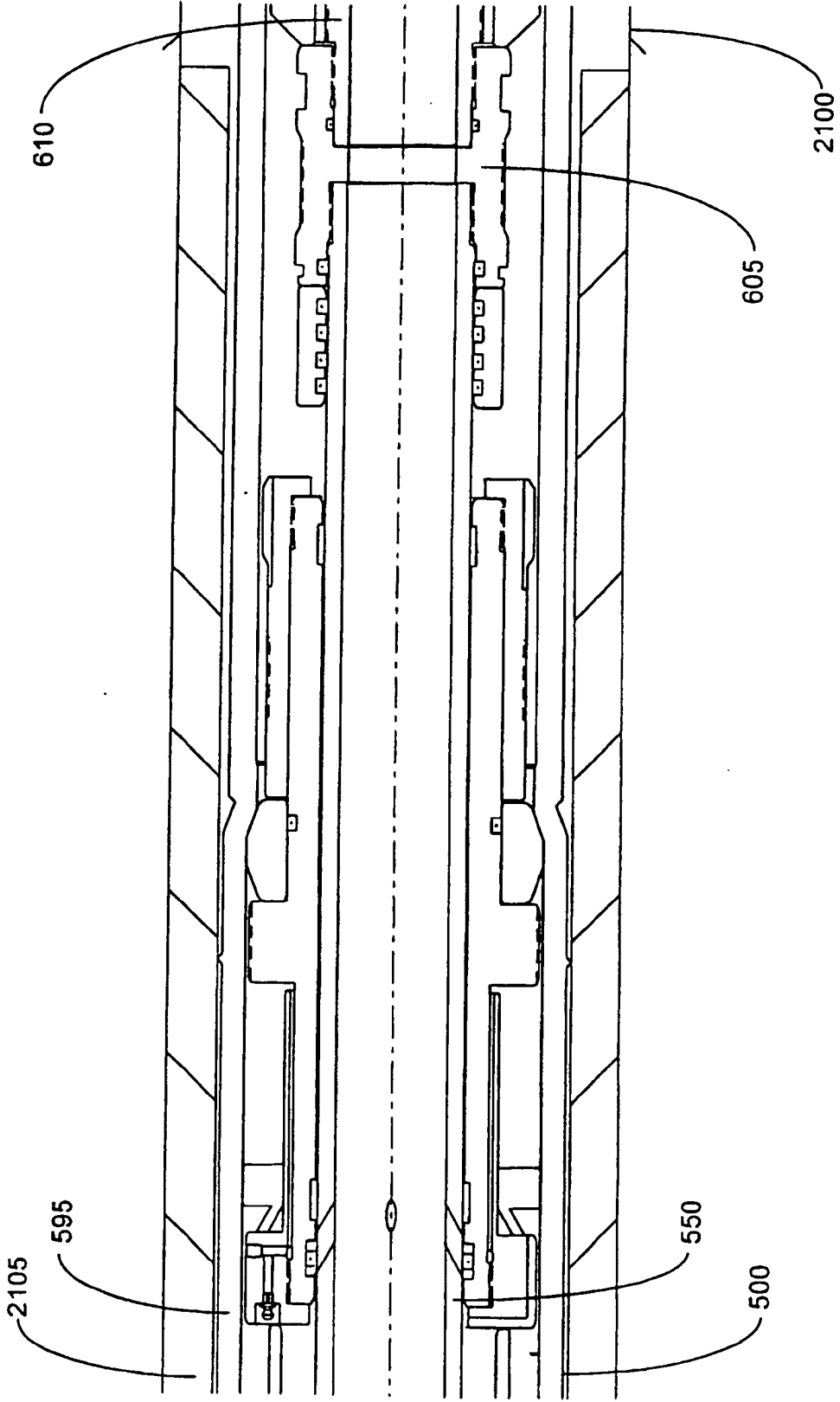

FIGURE 11C

7079

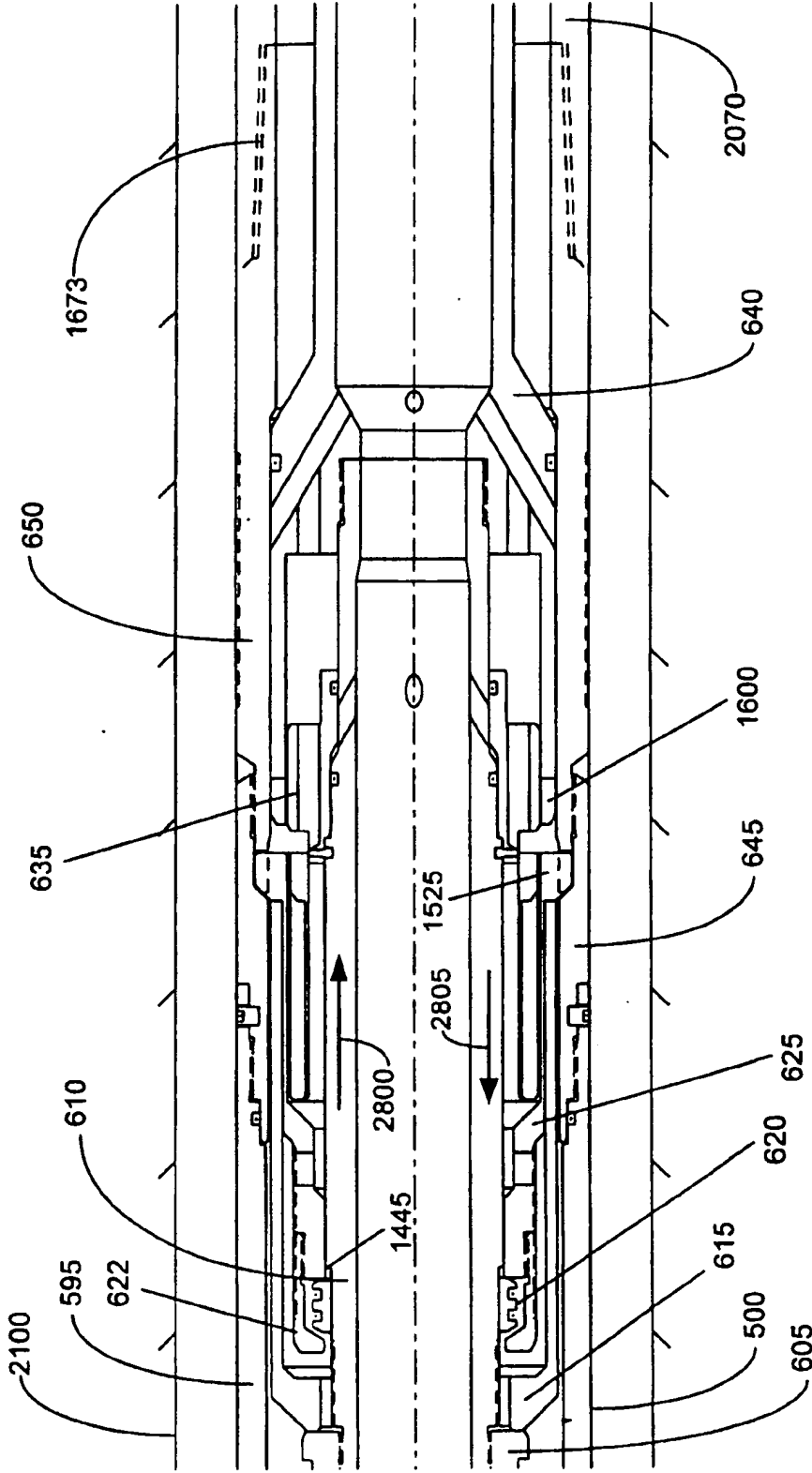

FIGURE 11D

7179

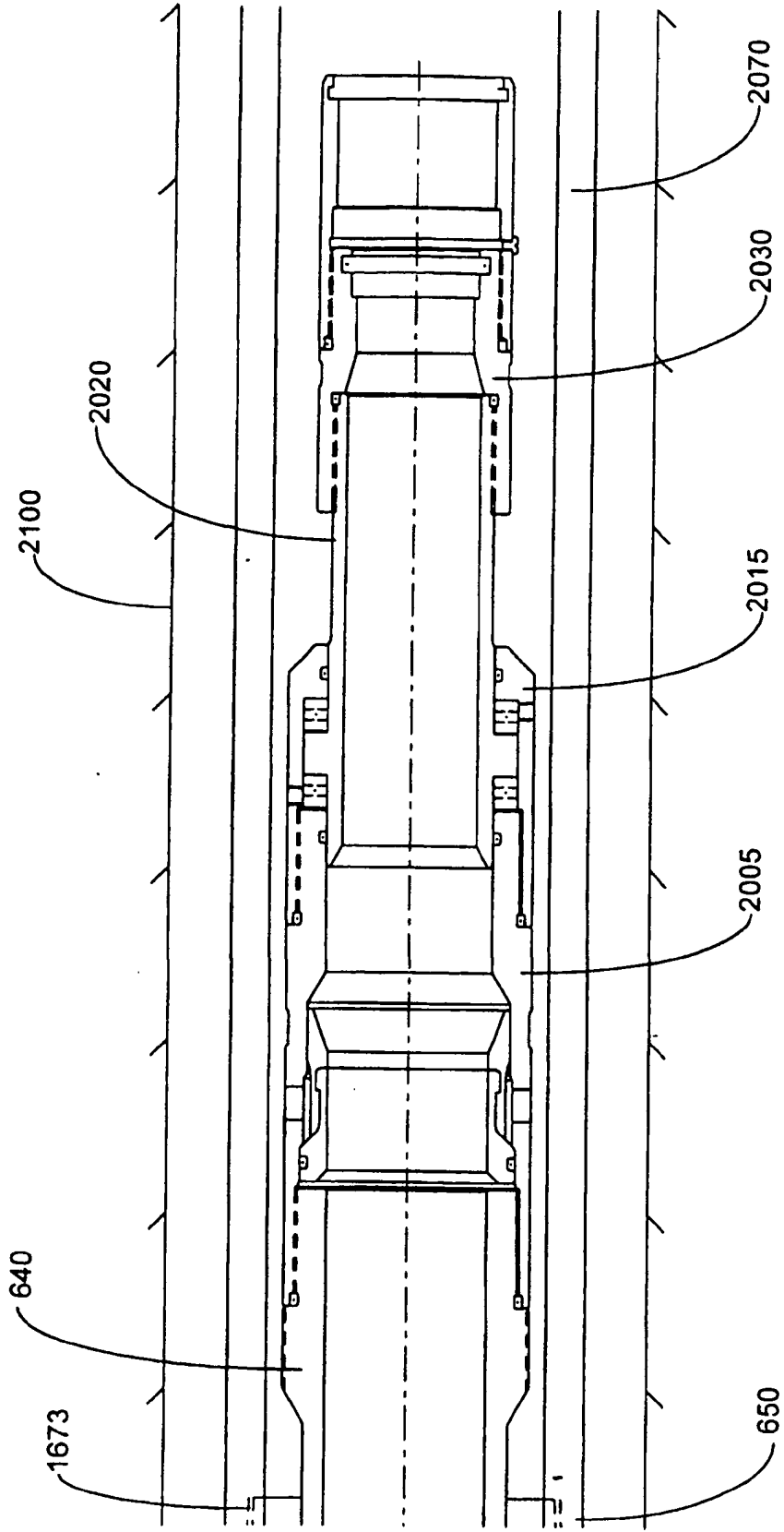

FIGURE 11E

72/79

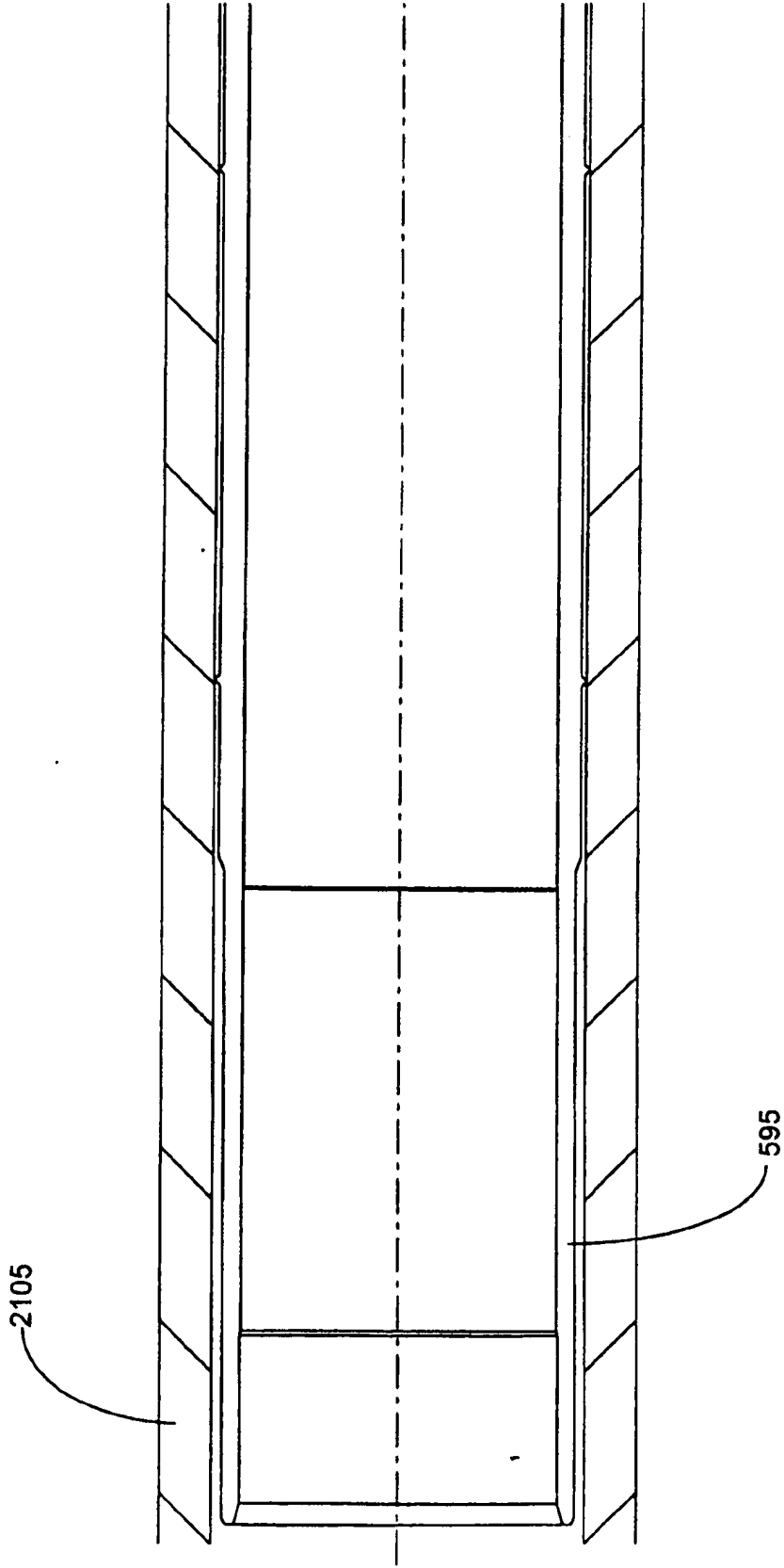

FIGURE 12A

73/79

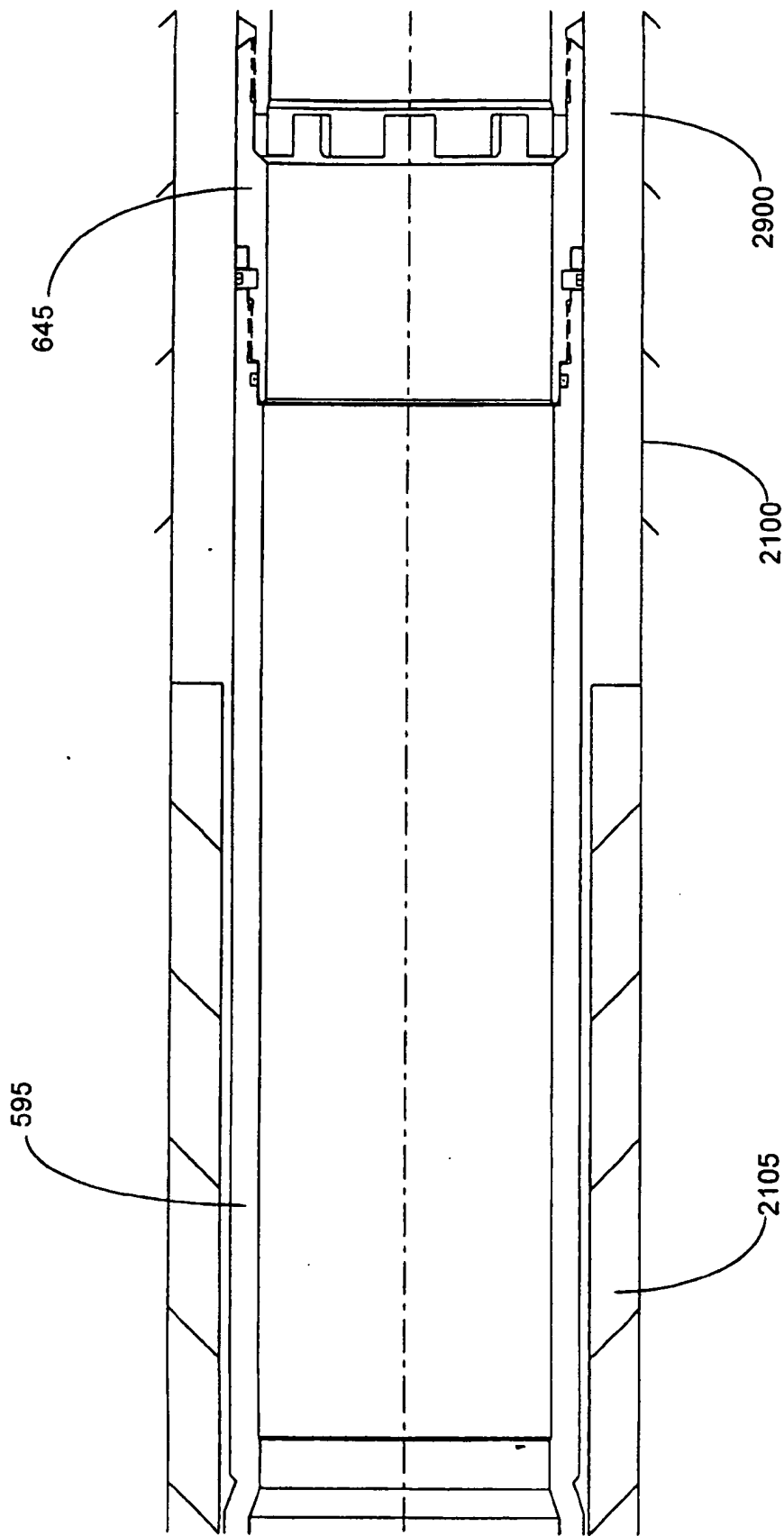

FIGURE 12B

7479

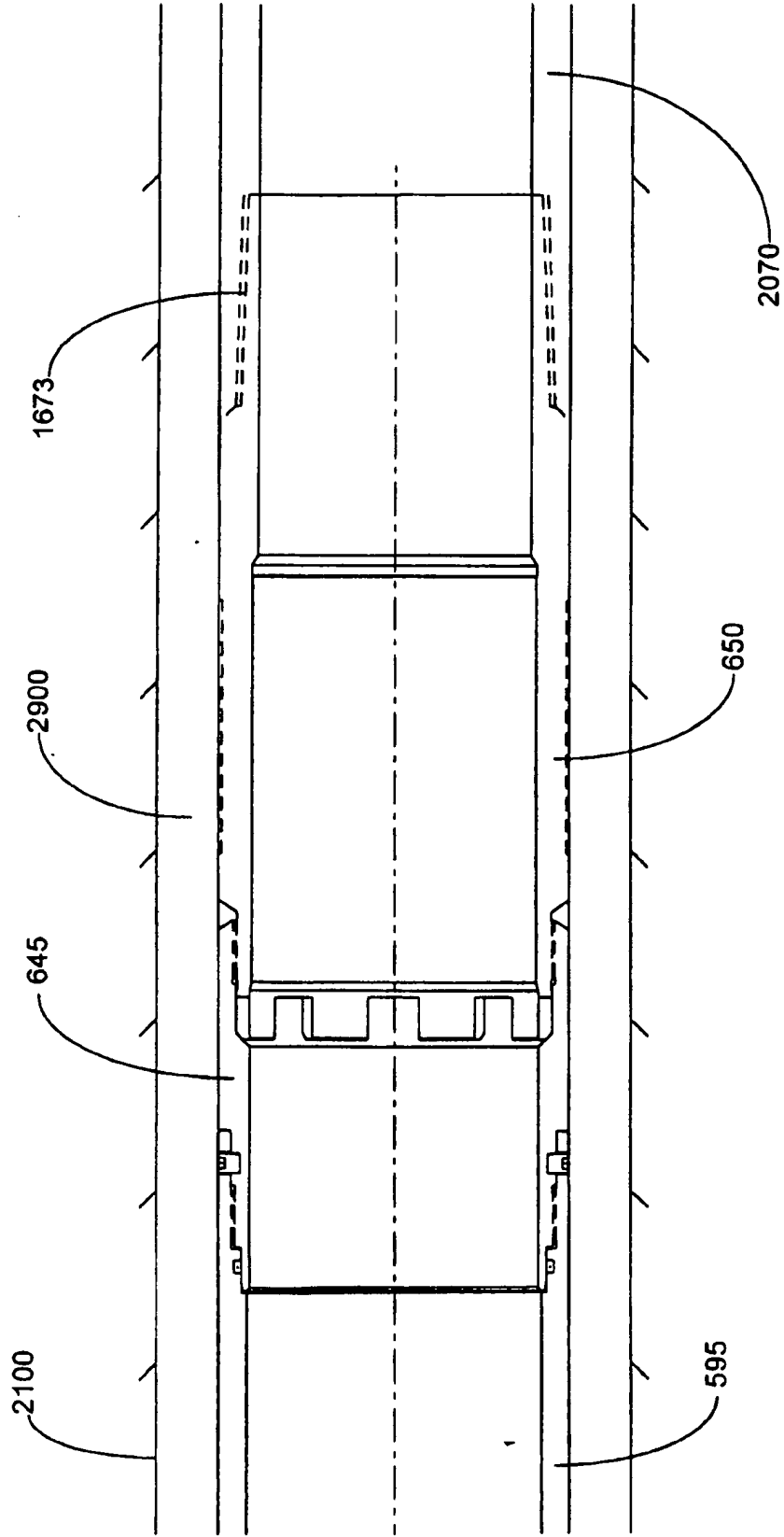

FIGURE 12C

75/79

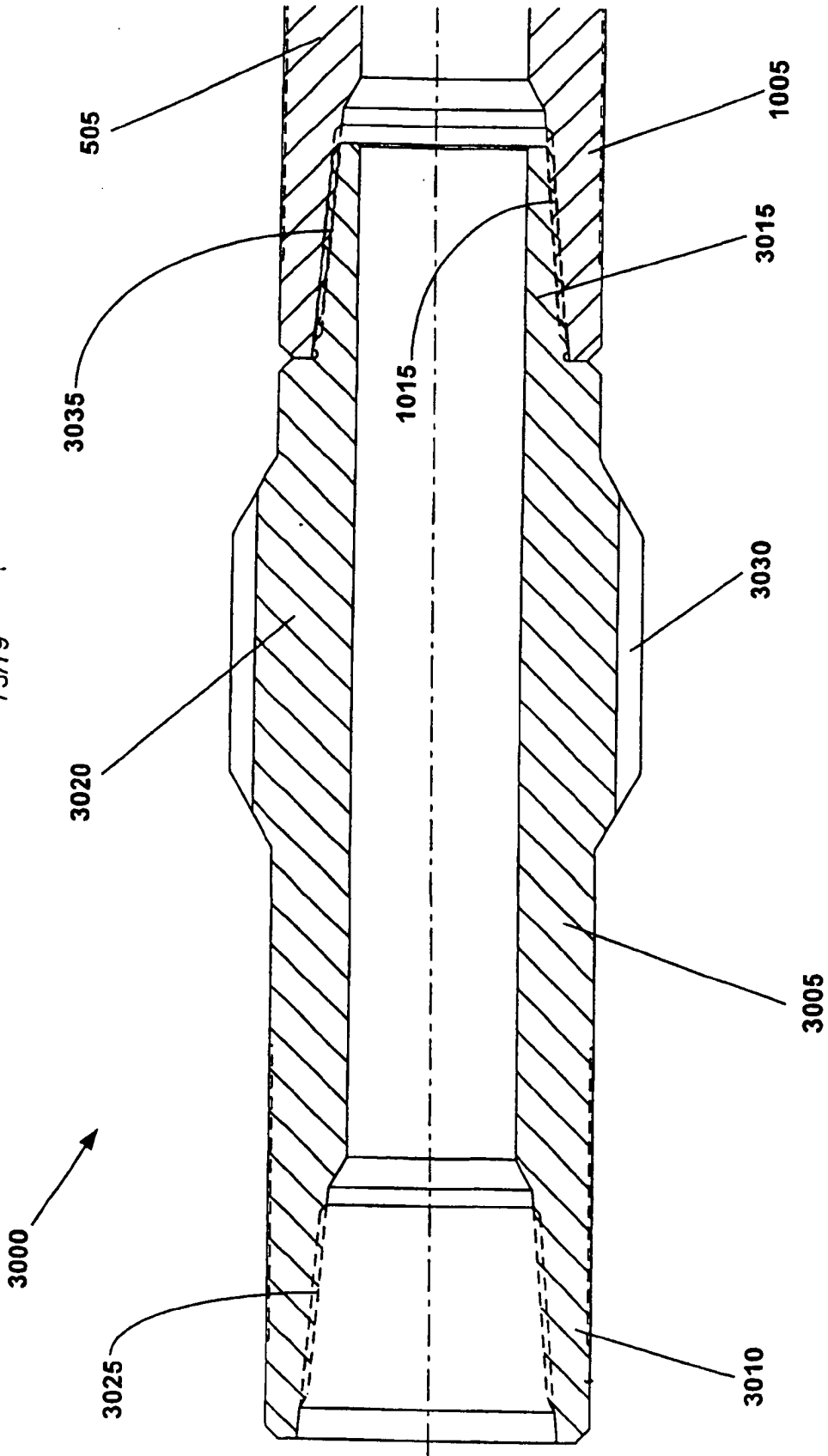

FIGURE 13A

76/79

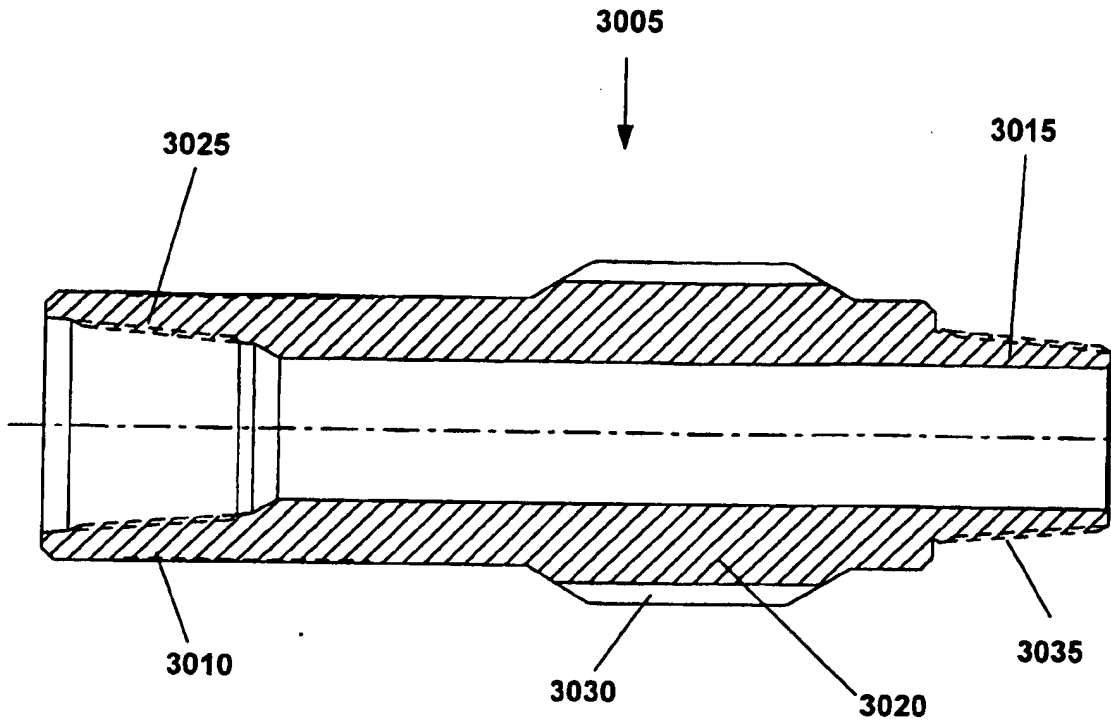

FIGURE 13B

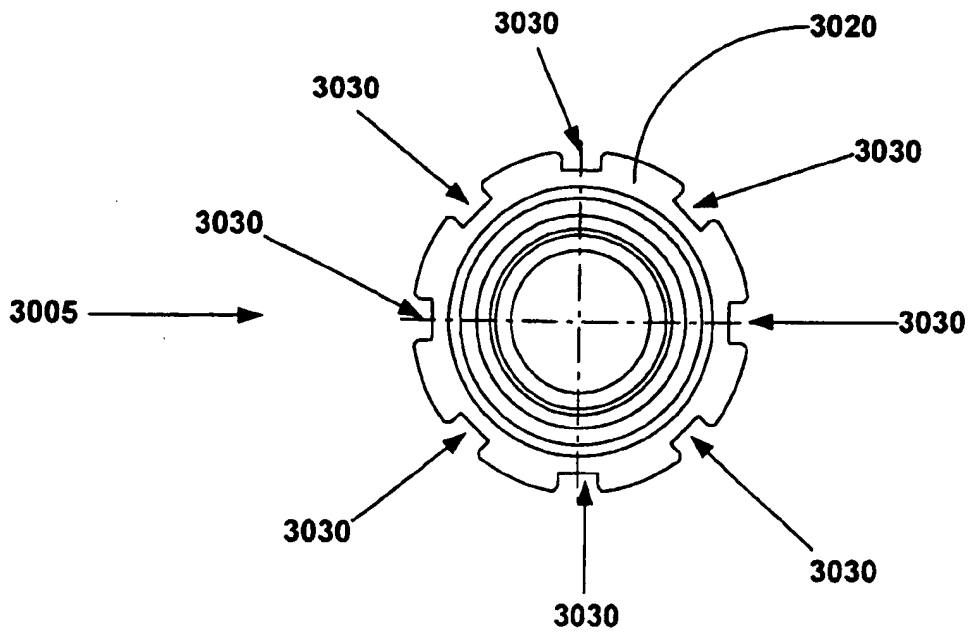

FIGURE 13G

77179

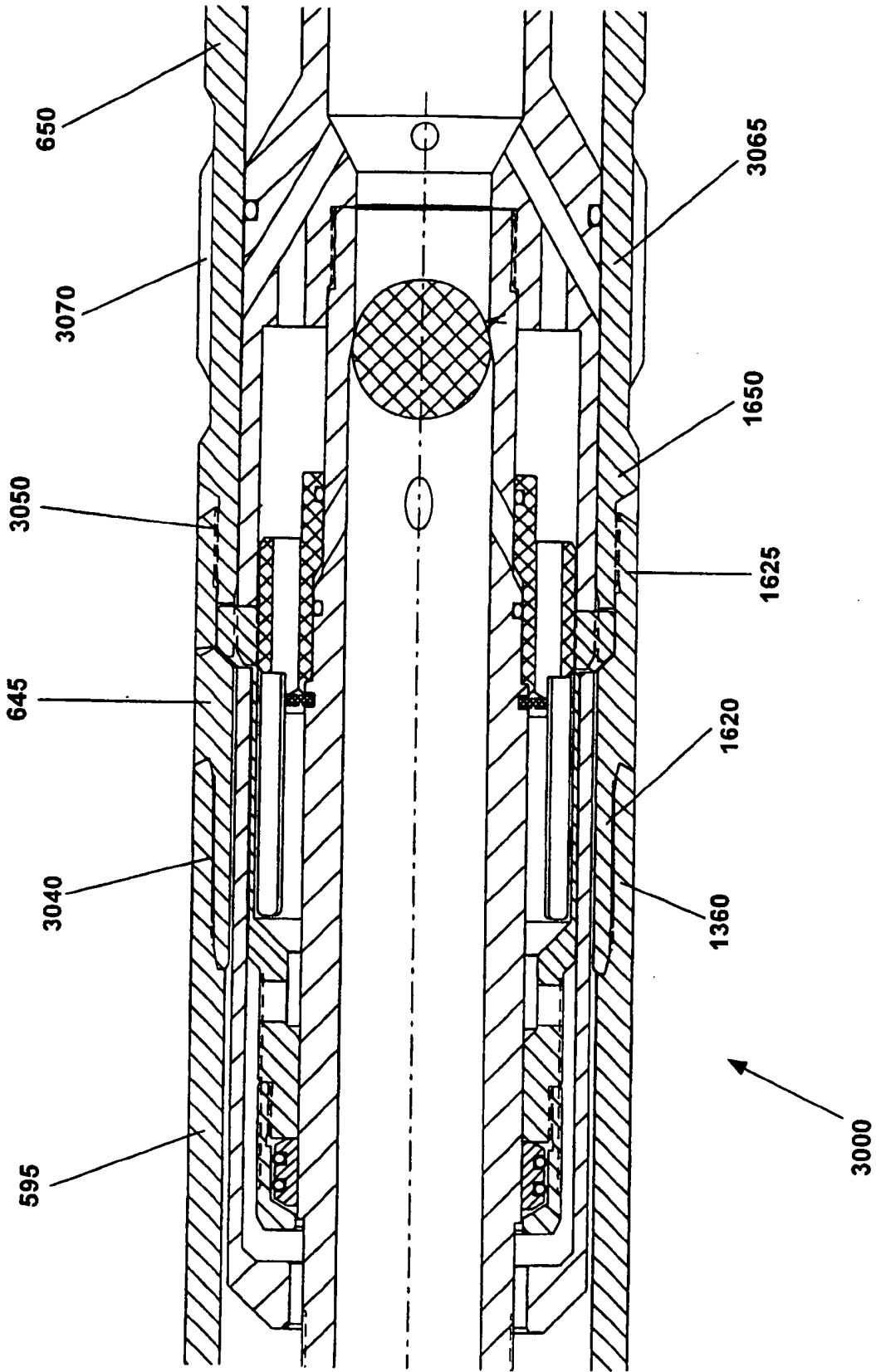

FIGURE 13D

78/79

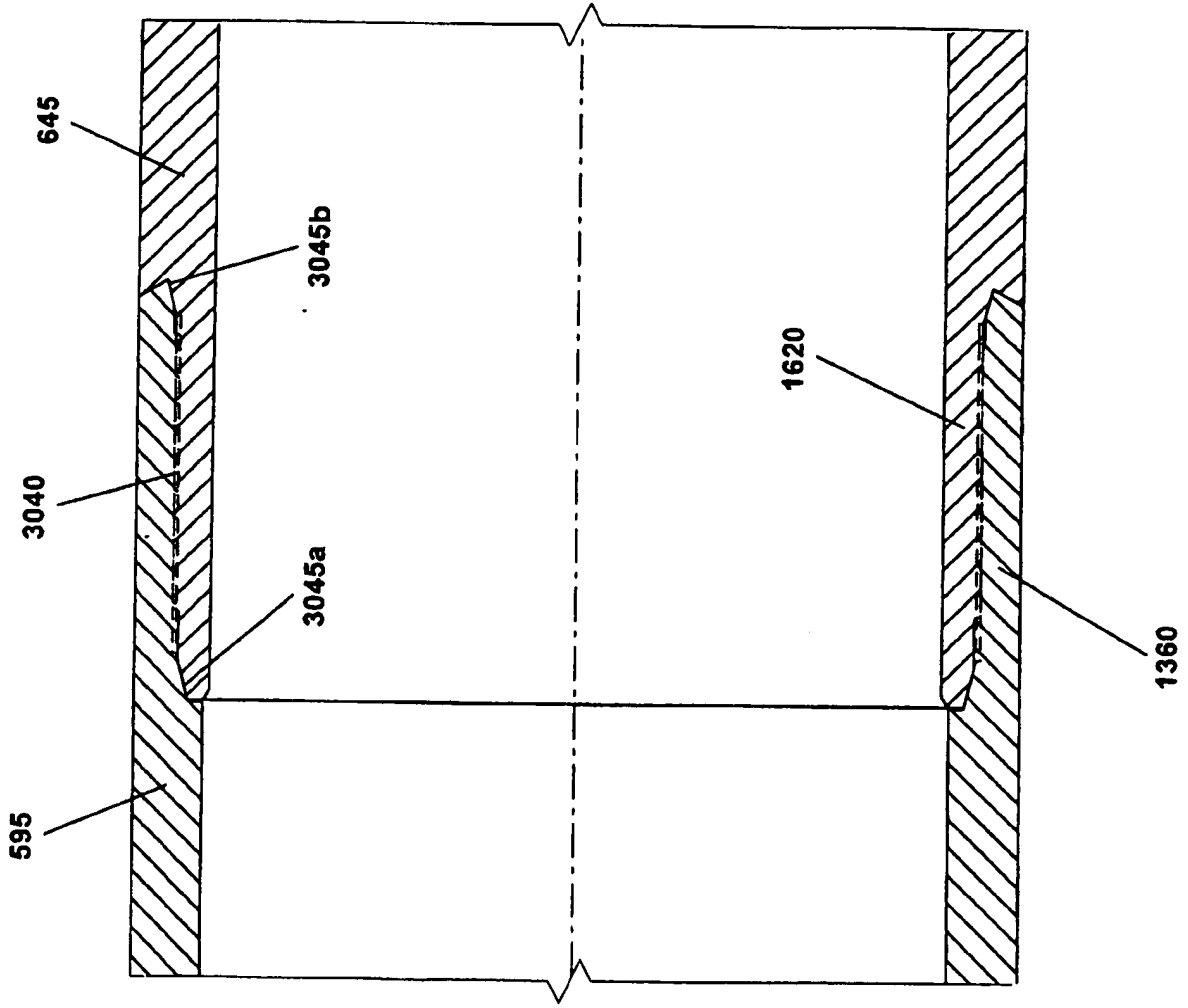

FIGURE 13E

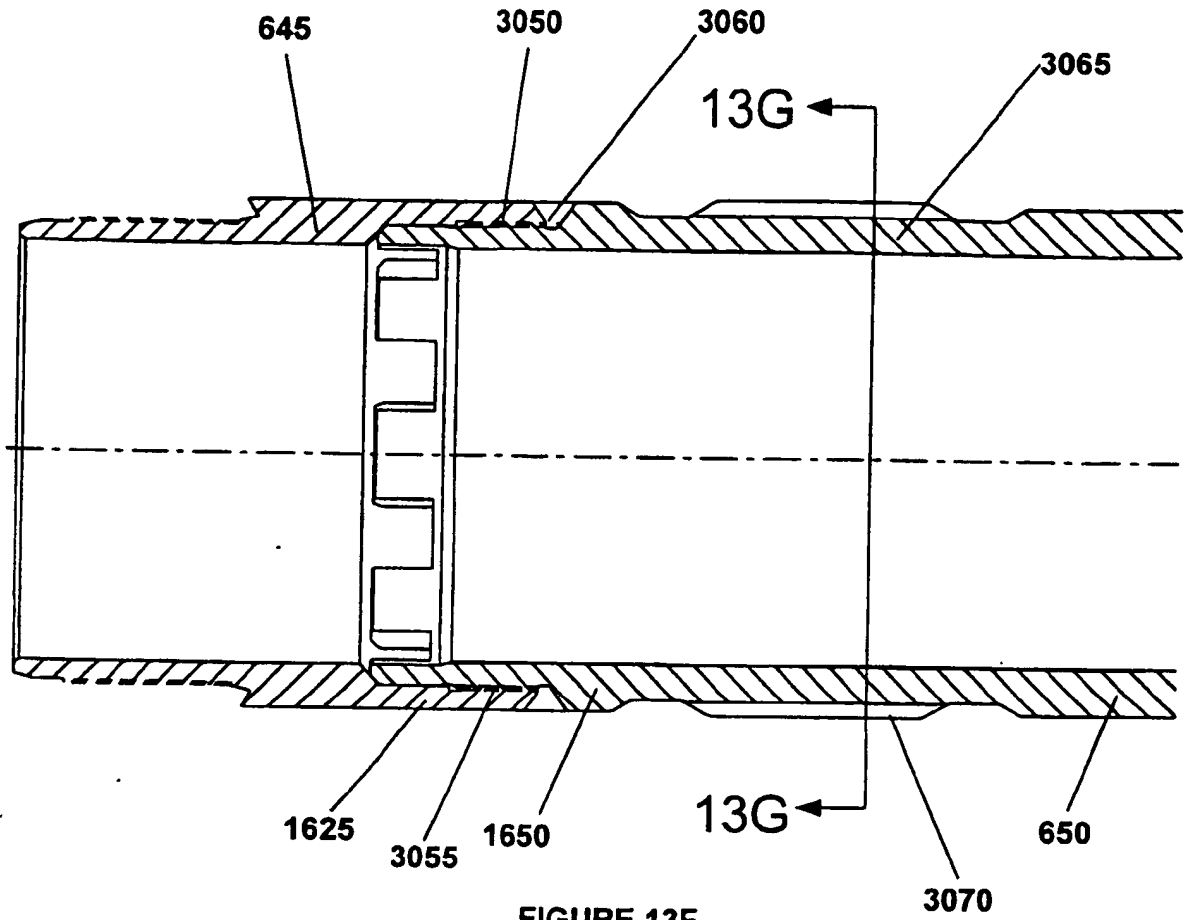

FIGURE 13F

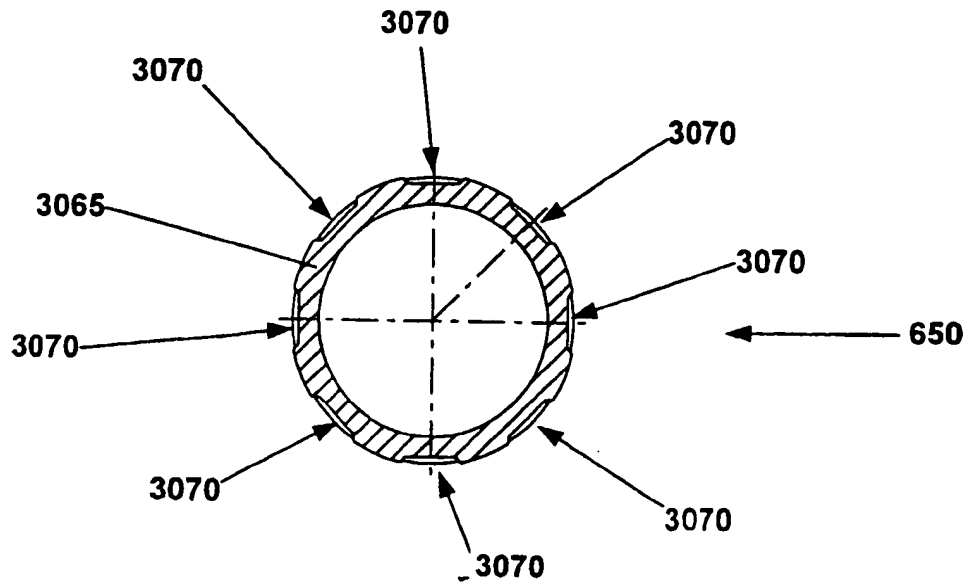

FIGURE 13G

2347957

**Apparatus For Coupling a Tubular Member to a Preexisting
Structure**

Background of the Invention

This invention relates generally to apparatus for coupling a tubular member to a preexisting structure.

Conventionally, when a wellbore is created, a number of casings are
5 installed in the borehole to prevent collapse of the borehole wall and to
prevent undesired outflow of drilling fluid into the formation or inflow of fluid
from the formation into the borehole. The borehole is drilled in intervals
whereby a casing which is to be installed in a lower borehole interval is
lowered through a previously installed casing of an upper borehole interval.
10 As a consequence of this procedure the casing of the lower interval is of
smaller diameter than the casing of the upper interval. Thus, the casings are
in a nested arrangement with casing diameters decreasing in downward
direction. Cement annuli are provided between the outer surfaces of the
casings and the borehole wall to seal the casings from the borehole wall. As a
15 consequence of this nested arrangement a relatively large borehole diameter
is required at the upper part of the wellbore. Such a large borehole diameter
involves increased costs due to heavy casing handling equipment, large drill
bits and increased volumes of drilling fluid and drill cuttings. Moreover,
increased drilling rig time is involved due to required cement pumping,
20 cement hardening, required equipment changes due to large variations in hole
diameters drilled in the course of the well, and the large volume of cuttings
drilled and removed.

Conventionally, at the surface end of the wellbore, a wellhead is formed
that typically includes a surface casing, a number of production and/or drilling
25 spools, valving, and a Christmas tree. Typically the wellhead further includes
a concentric arrangement of casings including a production casing and one or
more intermediate casings. The casings are typically supported using load
bearing slips positioned above the ground. The conventional design and
construction of wellheads is expensive and complex.

The present invention is directed to overcoming one or more of the limitations of the existing procedures for forming wellbores and wellheads.

Summary of the Invention

- 5 According to a first aspect of the present invention, there is provided an apparatus for coupling a tubular member to a preexisting structure, comprising:
- a first support member defining a first fluid passage;
 - a manifold coupled to the first support member defining:
 - 10 a second fluid passage coupled to the first fluid passage including a throat passage adapted to receive a plug;
 - a third fluid passage coupled to the second fluid passage; and
 - a fourth fluid passage coupled to the second fluid passage;
 - a second support member coupled to the manifold defining a fifth fluid
 - 15 passage coupled to the second fluid passage;
 - an expansion cone coupled to the second support member;
 - a tubular member coupled to the first support member;
 - a first interior chamber defined by the portion of the tubular member above the manifold, the first interior chamber coupled to the fourth fluid
 - 20 passage;
 - a second interior chamber defined by the portion of the tubular member between the manifold and the expansion cone, the second interior chamber coupled to the third fluid passage;
 - a third interior chamber defined by the portion of the tubular member
 - 25 below the expansion cone, the third interior chamber coupled to the fifth fluid passage; and
 - a shoe coupled to the tubular member defining:
 - a throat passage coupled to the third interior chamber adapted to receive a wiper dart; and a sixth fluid passage coupled to the throat passage.

30

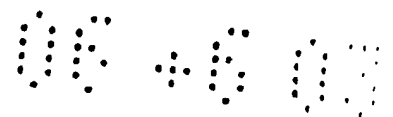

Preferably, the manifold is positioned above the expansion cone.

Preferably, the manifold is spaced apart from the expansion cone.

Preferably, the first interior chamber comprises an annular chamber.

Preferably, the second interior chamber comprises an annular chamber.

5 Preferably, the third interior chamber comprises an annular chamber.

Preferably, the expansion cone is movably coupled to the second support member.

Preferably, the first support member further defines a pressure relief passage.

10 Preferably, the third fluid passage is coupled to the second fluid passage upstream from the throat passage defined by the manifold.

Preferably, the fourth fluid passage is coupled to the second fluid passage downstream from the throat passage defined by the manifold.

15 Preferably, the third fluid passage is coupled to the second fluid passage upstream from the throat passage defined by the manifold; and the fourth fluid passage is coupled to the second fluid passage downstream from the throat passage defined by the manifold.

20 Preferably, the tubular member comprises an upper tubular portion having a first inside diameter; and a lower tubular portion having a second inside diameter; the first inside diameter being greater than the second inside diameter.

Preferably, the manifold is positioned within the upper tubular portion of the tubular member.

25 Preferably, the apparatus further comprises one or more sealing members coupled to the manifold for fluidically sealing the interface between the manifold and the upper tubular portion of the tubular member.

30 Preferably, a portion of the expansion cone is positioned within the upper tubular portion of the tubular member; another portion of the expansion cone being positioned within the lower tubular portion of the tubular member.

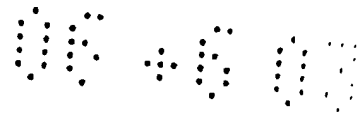

Preferably, the apparatus further comprises one or more sealing members coupled to the other portion of the expansion cone for fluidically sealing the interface between the expansion cone and the lower tubular portion of the tubular member.

5 Preferably, the first interior chamber is fluidically isolated from the second interior chamber.

Preferably, the second interior chamber is fluidically isolated from the third interior chamber.

10 Preferably, the third interior chamber is fluidically isolated from the first interior chamber.

Preferably, the apparatus further comprises one or more sealing members coupled to the expansion cone for fluidically sealing the interface between the expansion cone and the tubular member.

15 Preferably, the apparatus further comprises one or more sealing members coupled to the manifold for fluidically sealing the interface between the manifold and the tubular member.

According to a second aspect of the present invention, there is provided an apparatus for coupling a tubular member to a preexisting structure, comprising:

20 a first support member defining a first fluid passage and a pressure relief passage controllably coupled to the first fluid passage;

a manifold coupled to the first support member defining:

a second fluid passage coupled to the first fluid passage including a throat passage adapted to receive a plug;

25 a third fluid passage coupled to the second fluid passage; and

a fourth fluid passage coupled to the second fluid passage;

wherein the third fluid passage is coupled to the second fluid passage upstream from the throat passage; and wherein the fourth fluid passage is coupled to the second fluid passage downstream from the throat passage;

30 a second support member coupled to the manifold defining a fifth fluid passage coupled to the second fluid passage;

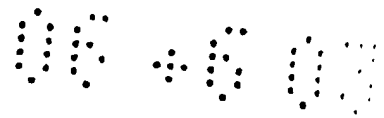

an expansion cone movably coupled to the second support member below and spaced apart from the manifold;

a tubular member coupled to the first support member, comprising:
an upper tubular portion having a first inside diameter; and

5 a lower tubular portion having a second inside diameter;
wherein the first inside diameter is greater than the second inside diameter;

one or more first sealing members coupled to the manifold for fluidically sealing the interface between the manifold and the upper tubular portion of
10 the tubular member;

one or more second sealing members coupled to the expansion cone for fluidically sealing the interface between the expansion cone and the lower tubular portion of the tubular member;

a first interior annular chamber defined by the portion of the tubular
15 member above the manifold, the first interior chamber coupled to the fourth fluid passage;

a second interior annular chamber defined by the portion of the tubular member between the manifold and the expansion cone, the second interior chamber coupled to the third fluid passage;

20 a third interior annular chamber defined by the portion of the tubular member below the expansion cone, the third interior chamber coupled to the fifth fluid passage; and

a shoe coupled to the tubular member defining:

a throat passage coupled to the third interior chamber adapted to
25 receive a wiper dart; and

a sixth fluid passage coupled to the throat passage;

wherein the first interior chamber is fluidically isolated from the second interior chamber;

wherein the second interior chamber is fluidically isolated from the third
30 interior chamber; and



wherein the third interior chamber is fluidically isolated from the first interior chamber.

Brief Description of the Drawings

FIG. 1A is a cross-sectional view illustrating the placement of an
5 embodiment of an apparatus for creating a casing within a well borehole.

FIG. 1B is a cross-sectional view illustrating the injection of a fluidic material into the well borehole of FIG. 1A.

FIG. 1C is a cross-sectional view illustrating the injection of a wiper plug into the apparatus of FIG. 1B.

10 FIG. 1D is a fragmentary cross-sectional view illustrating the injection of a ball plug and a fluidic material into the apparatus of FIG. 1C.

FIG. 1E is a fragmentary cross-sectional view illustrating the continued injection of fluidic material into the apparatus of FIG. 1D in order to radially expand a tubular member.

15 FIG. 1F is a cross-sectional view of the completed wellbore casing.

FIG. 2A is a cross-sectional illustration of a portion of an apparatus for forming and/or repairing a wellbore, pipeline or structural support.

FIG. 2B is an enlarged illustration of a portion of the apparatus of FIG.
2A.

20 FIG. 2C is an enlarged illustration of a portion of the apparatus of FIG.
2A.

FIG. 2D is an enlarged illustration of a portion of the apparatus of FIG.
2A.

FIG. 2E is a cross-sectional illustration of the apparatus of FIG. 2A.

25 FIG. 2F is a cross-sectional illustration of another portion of the
apparatus of FIG. 2A.

FIG. 2G is an enlarged illustration of a portion of the apparatus of FIG.
2F.

30 FIG. 2H is an enlarged illustration of a portion of the apparatus of FIG.
2F.



FIG. 2I is an enlarged illustration of a portion of the apparatus of FIG. 2F.

FIG. 2J is a cross-sectional illustration of another portion of the apparatus of FIG. 2A.

5 FIG. 2K is an enlarged illustration of a portion of the apparatus of FIG. 2J.

FIG. 2L is an enlarged illustration of a portion of the apparatus of FIG. 2J.

10 FIG. 2M is an enlarged illustration of a portion of the apparatus of FIG. 2J.

FIG. 2N is an enlarged illustration of a portion of the apparatus of FIG. 2J.

FIG. 2O is a cross-sectional illustration of the apparatus of FIG. 2J.

15 FIGS. 3A to 3D are exploded views of a portion of the apparatus of FIGS. 2A to 2O.

FIG. 3E is a cross-sectional illustration of the outer collet support member and the liner hanger setting sleeve of the apparatus of FIGS. 2A to 2O.

20 FIG. 3F is a front view of the locking dog spring of the apparatus of FIGS. 2A to 2O.

FIG. 3G is a front view of the locking dogs of the apparatus of FIGS. 2A to 2O.

FIG. 3H is a front view of the collet assembly of the apparatus of FIGS. 2A to 2O.

25 FIG. 3I is a front view of the collet retaining sleeve of the apparatus of FIGS. 2A to 2O.

FIG. 3J is a front view of the collet retaining adaptor of the apparatus of FIGS. 2A to 2O.

30 FIGS. 4A to 4G are fragmentary cross-sectional illustrations of a method for placing the apparatus of FIGS. 2A-2O within a wellbore.

FIGS. 5A to 5C are fragmentary cross-sectional illustrations of a method for decoupling the liner hanger, the outer collet support member, and the liner hanger setting sleeve from the apparatus of FIGS. 4A to 4G.

FIGS. 6A to 6C are fragmentary cross-sectional illustrations of a
5 method for releasing the lead wiper from the apparatus of FIGS. 4A to 4G.

FIGS. 7A to 7G are fragmentary cross-sectional illustration of a method for cementing the region outside of the apparatus of FIGS. 6A to 6C.

FIGS. 8A to 8C are fragmentary cross-sectional illustrations of a method for releasing the tail wiper from the apparatus of FIGS. 7A to 7G.

10 FIGS. 9A to 9H are fragmentary cross-sectional illustrations of a method of radially expanding the liner hanger of the apparatus of FIGS. 8A to 8C.

FIGS. 10A to 10E are fragmentary cross-sectional illustrations of the completion of the radial expansion of the liner hanger using the apparatus of
15 FIGS. 9A to 9H.

FIGS. 11A to 11E are fragmentary cross-sectional illustrations of the decoupling of the radially expanded liner hanger from the apparatus of FIGS. 10A to 10E.

FIGS. 12A to 12C are fragmentary cross-sectional illustrations of the
20 completed wellbore casing.

FIG. 13A is a cross-sectional illustration of a portion of an apparatus for forming and/or repairing a wellbore, pipeline or structural support.

FIG. 13B is a cross-sectional view of the standoff adaptor of the apparatus of FIG. 13A.

25 FIG. 13C is a front view of the standoff adaptor of FIG. 13B.

FIG. 13D is a cross-sectional illustration of another portion of the apparatus of FIG. 13A.

FIG. 13E is an enlarged view of the threaded connection between the liner hanger and the outer collet support member of FIG. 13D.

30 FIG. 13F is an enlarged view of the connection between the outer collet support member 645 and the liner hanger setting sleeve 650 of FIG. 13D.

FIG. 13G is a cross-sectional view of the liner hanger setting sleeve of FIG. 13F.

Referring initially to Figs. 1A-1F, an embodiment of an apparatus and method for forming a wellbore casing within a subterranean formation will now be described. As illustrated in Fig. 1A, a wellbore 100 is positioned in a subterranean formation 105. The wellbore 100 includes an existing cased section 110 having a tubular casing 115 and an annular outer layer of cement 120.

As illustrated in Fig. 1A, an apparatus 200 for forming a wellbore casing in a subterranean formation is then positioned in the wellbore 100. The apparatus 200 preferably includes a first support member 205, a manifold 210, a second support member 215, a tubular member 220, a shoe 225, an expansion cone 230, first sealing members 235, second sealing members 240, third sealing members 245, fourth sealing members 250, an anchor 255, a first passage 260, a second passage 265, a third passage 270, a fourth passage 275, a throat 280, a fifth passage 285, a sixth passage 290, a seventh passage 295, an annular chamber 300, a chamber 305, and a chamber 310. The apparatus 200 is used to radially expand the tubular member 220 into intimate contact with the tubular casing 115. In this manner, the tubular member 220 is coupled to the tubular casing 115. In this manner, the apparatus 200 is preferably used to form or repair a wellbore casing, a pipeline, or a structural support. In a particularly preferred embodiment, the apparatus is used to repair or form a wellbore casing.

The first support member 205 is coupled to a conventional surface support and the manifold 210. The first support member 205 may be fabricated from any number of conventional commercially available tubular support members. The first support member 205 is fabricated from alloy steel having a minimum yield strength of about 75,000 to 140,000 psi (5,171.07 to 9,652.66 bar) in order to provide high strength and resistance to abrasion and fluid erosion. The first support member 205 further includes the first passage 260 and the second passage 265.

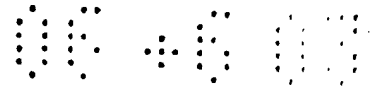

The manifold 210 is coupled to the first support member 205, the second support member 215, the sealing members 235a and 235b, and the tubular member 200. The manifold 210 preferably includes the first passage 260, the third passage 270, the fourth passage 275, the throat 280 and the fifth
5 passage 285. The manifold 210 may be fabricated from any number of conventional tubular members.

The second support member 215 is coupled to the manifold 210, the sealing members 245a, 245b, and 245c, and the expansion cone 230. The second support member 215 may be fabricated from any number of
10 conventional commercially available tubular support members. The second support member 215 is fabricated from alloy steel having a minimum yield strength of about 75,000 to 140,000 psi (5,171.07 to 9,652.66 bar) in order to provide high strength and resistance to abrasion and fluid erosion. The second support member 215 further includes the fifth passage 285.

15 The tubular member 220 is coupled to the sealing members 235a and 235b and the shoe 225. The tubular member 220 is further movably coupled to the expansion cone 230 and the sealing members 240a and 240b. The first support member 205 may comprise any number of conventional tubular members. The tubular member 220 may be fabricated from any number of
20 conventional commercially available tubular members. The tubular member 220 is further provided substantially as described in one or more of the following: (1) U.S. Patent Application Serial No.09/440,338, attorney docket number 25791.9.02, filed on 11/15/98, which claimed benefit of the filing date of U.S. Provisional Patent Application Serial Number 60/108,558, attorney
25 docket number 25791.9, filed on 11/16/1998, (2) U.S. Patent Application Serial No.09/454,139, attorney docket number 25791.3.02, filed on 12/3/99, which claimed benefit of the filing date of U.S. Provisional Patent Application Serial Number 60/111,293, filed on 12/7/1998, (3) U.S. Patent Application Serial
30 Number 09/502,350 attorney docket number 25791.8.02, filed on 2/10/00, which claimed the benefit of the filing date of U.S. Provisional Patent Application Serial Number 60/119,611, attorney docket number 25791.8, filed

- 2/11/1999, (4) U.S. Patent Application Serial Number 09/510,913, attorney docket number 25791.7.02, filed on 2/23/00, which claimed the benefit of the filing date of U.S. Provisional Patent Application Serial Number 60/121,702, attorney docket number 25791.7, filed on 2/25/1999, (5) U.S. Patent
- 5 Application Serial Number 09/511,941, attorney docket number 25791.16.02, filed on 2/24/00, which claimed the benefit of the filing date of U.S. Provisional Patent Application number 60/121,907, attorney docket number 25791.16, filed 2/26/1999, (6) U.S. Provisional Patent Application Serial Number 60/124,042, attorney docket number 25791.11, filed on 3/11/1999, (7) U.S.
- 10 Provisional Patent Application Serial Number 60/131,106, attorney docket number 25791.23, filed on 4/26/1999, (8) U.S. Provisional Patent Application Serial Number 60/137,998, attorney docket number 25791.17, filed on 6/7/1999, (9) U.S. Provisional Patent Application Serial Number 60/143,039, attorney docket number 25791.26, filed on 7/9/1999, and (10) U.S. Provisional
- 15 Patent Application Serial Number 60/146,203, attorney docket number 25791.25, filed on 7/29/1999, the disclosures of which are incorporated by reference.

The shoe 225 is coupled to the tubular member 220. The shoe 225 preferably includes the sixth passage 290 and the seventh passage 295. The

20 shoe 225 preferably is fabricated from a tubular member. The shoe 225 is further provided substantially as described in one or more of the following: (1) U.S. Patent Application Serial No. 09/440,338, attorney docket number 25791.9.02, filed on 11/15/98, which claimed benefit of the filing date of U.S. Provisional Patent Application Serial Number 60/108,558, attorney docket

25 number 25791.9, filed on 11/16/1998, (2) U.S. Patent Application Serial No.09/454,139, attorney docket number 25791.3.02, filed on 12/3/99, which claimed benefit of the filing date of U.S. Provisional Patent Application Serial Number 60/111,293, filed on 12/7/1998, (3) U.S. Patent Application Serial

30 Number 09/502,350, attorney docket number 25791.8.02, filed on 2/10/00, which claimed the benefit of the filing date of U.S. Provisional Patent Application Serial Number 60/119,611, attorney docket number 25791.8, filed

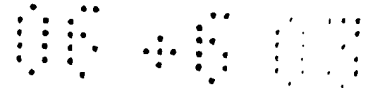

- 2/11/1999, (4) U.S. Patent Application Serial Number 09/510,913, attorney docket number 25791.7.02, filed on 2/23/00, which claimed the benefit of the filing date of U.S. Provisional Patent Application Serial Number 60/121,702, attorney docket number 25791.7, filed on 2/25/1999, (5) U.S. Patent
- 5 Application Serial Number 09/511,941, attorney docket number 25791.16.02, filed on 2/24/00, which claimed the benefit of the filing date of U.S. Provisional Patent Application number 60/121,907, attorney docket number 25791.16, filed 2/26/1999, (6) U.S. Provisional Patent Application Serial Number 60/124,042, attorney docket number 25791.11, filed on 3/11/1999, (7) U.S.
- 10 Provisional Patent Application Serial Number 60/131,106, attorney docket number 25791.23, filed on 4/26/1999, (8) U.S. Provisional Patent Application Serial Number 60/137,998, attorney docket number 25791.17, filed on 6/7/1999, (9) U.S. Provisional Patent Application Serial Number 60/143,039, attorney docket number 25791.26, filed on 7/9/1999, and (10) U.S. Provisional
- 15 Patent Application Serial Number 60/146,203, attorney docket number 25791.25, filed on 7/29/1999, the disclosures of which are incorporated by reference.

The expansion cone 230 is coupled to the sealing members 240a and 240b and the sealing members 245a, 245b, and 245c. The expansion cone 230

20 is movably coupled to the second support member 215 and the tubular member 220. The expansion cone 230 preferably includes an annular member having one or more outer conical surfaces for engaging the inside diameter of the tubular member 220. In this manner, axial movement of the expansion cone 230 radially expands the tubular member 220. The expansion cone 230

25 is further provided substantially as described in one or more of the following:

(1) U.S. Patent Application Serial No.09/440,338, attorney docket number 25791.9.02, filed on 11/15/98, which claimed benefit of the filing date of U.S. Provisional Patent Application Serial Number 60/108,558, attorney docket number 25791.9, filed on 11/16/1998, (2) U.S. Patent Application Serial No.

30 09/454,139, attorney docket number 25791.3.02, filed on 12/3/99, which claimed benefit of the filing date of U.S. Provisional Patent Application Serial

000000000000

Number 60/111,293, filed on 12/7/1998, (3) U.S. Patent Application Serial Number 09/502,350 attorney docket number 25791.8.02, filed on 2/10/00, which claimed the benefit of the filing date of U.S. Provisional Patent Application Serial Number 60/119,611, attorney docket number 25791.8, filed 5 2/11/1999, (4) U.S. Patent Application Serial Number 09/510,913, attorney docket number 25791.7.02, filed on 2/23/00, which claimed the benefit of the filing date of U.S. Provisional Patent Application Serial Number 60/121,702, attorney docket number 25791.7, filed on 2/25/1999, (5) U.S. Patent Application Serial Number 09/511,941, attorney docket number 25791.16.02, 10 filed on 2/24/00, which claimed the benefit of the filing date of U.S. Provisional Patent Application number 60/121,907, attorney docket number 25791.16, filed 2/26/1999, (6) U.S. Provisional Patent Application Serial Number 60/124,042, attorney docket number 25791.11, filed on 3/11/1999, (7) U.S. Provisional Patent Application Serial Number 60/131,106, attorney docket 15 number 25791.23, filed on 4/26/1999, (8) U.S. Provisional Patent Application Serial Number 60/137,998, attorney docket number 25791.17, filed on 6/7/1999, (9) U.S. Provisional Patent Application Serial Number 60/143,039, attorney docket number 25791.26, filed on 7/9/1999, and (10) U.S. Provisional Patent Application Serial Number 60/146,203, attorney docket number 20 25791.25, filed on 7/29/1999, the disclosures of which are incorporated by reference.

The first sealing members 235a and 235b are coupled to the manifold 210 and the tubular member 220. The first sealing members 235a and 235b preferably fluidically isolate the annular chamber 300 from the chamber 310. 25 In this manner, annular chamber 300 is optimally pressurized during operation of the apparatus 200. The first sealing members 235a and 235b may comprise any number of conventional commercially available sealing members. The first sealing members 235a and 235b include O-rings with seal backups available from Parker Seals in order to provide a fluidic seal between 30 the tubular member 200 and the expansion cone 230 during axial movement of the expansion cone 230.



The first sealing member 235a and 235b further include conventional controllable latching members for removably coupling the manifold 210 to the tubular member 200. In this manner, the tubular member 200 is optimally supported by the manifold 210. Alternatively, the tubular member 200 is preferably removably supported by the first support member 205 using conventional controllable latching members.

The second sealing members 240a and 240b are coupled to the expansion cone 230. The second sealing members 240a and 240b are movably coupled to the tubular member 220. The second sealing members 240a and 240b preferably fluidically isolate the annular chamber 300 from the chamber 305 during axial movement of the expansion cone 230. In this manner, the annular chamber 300 is optimally pressurized. The second sealing members 240a and 240b may comprise any number of conventional commercially available sealing members.

The second sealing members 240a and 240b further include a conventional centralizer and/or bearings for supporting and positioning the expansion cone 230 within the tubular member 200 during axial movement of the expansion cone 230. In this manner, the position and orientation of the expansion cone 230 is optimally controlled during axial movement of the expansion cone 230.

The third sealing members 245a, 245b, and 245c are coupled to the expansion cone 230. The third sealing members 245a, 245b, and 245c are movably coupled to the second support member 215. The third sealing members 245a, 245b, and 245c preferably fluidically isolate the annular chamber 300 from the chamber 305 during axial movement of the expansion cone 230. In this manner, the annular chamber 300 is optimally pressurized. The third sealing members 245a, 245b and 240c may comprise any number of conventional commercially available sealing members. The third sealing members 245a, 245b, and 245c include O-rings with seal backups available from Parker Seals in order to provide a fluidic seal between the expansion

cone 230 and the second support member 215 during axial movement of the expansion cone 230.

The third sealing members 245a, 245b and 240c further include a conventional centralizer and/or bearings for supporting and positioning the expansion cone 230 around the second support member 215 during axial movement of the expansion cone 230. In this manner, the position and orientation of the expansion cone 230 is optimally controlled during axial movement of the expansion cone 230.

The fourth sealing member 250 is coupled to the tubular member 220. The fourth sealing member 250 preferably fluidically isolates the chamber 315 after radial expansion of the tubular member 200. In this manner, the chamber 315 outside of the radially expanded tubular member 200 is fluidically isolated. The fourth sealing member 250 may comprise any number of conventional commercially available sealing members. The fourth sealing member 250 is a RTTS packer ring available from Halliburton Energy Services in order to optimally provide a fluidic seal.

The anchor 255 is coupled to the tubular member 220. The anchor 255 preferably anchors the tubular member 200 to the casing 115 after radial expansion of the tubular member 200. In this manner, the radially expanded tubular member 200 is optimally supported within the wellbore 100. The anchor 255 may comprise any number of conventional commercially available anchoring devices. The anchor 255 includes RTTS mechanical slips available from Halliburton Energy Services in order to optimally anchor the tubular member 200 to the casing 115 after the radial expansion of the tubular member 200.

The first passage 260 is fluidically coupled to a conventional surface pump, the second passage 265, the third passage 270, the fourth passage 275, and the throat 280. The first passage 260 is preferably adapted to convey fluidic materials including drilling mud, cement and/or lubricants at flow rates and pressures ranging from about 0 to 650 gallons/minute and 0 to 10,000 psi (0 to 2,460.52 litre/minute and 0 to 689.48 bar), respectively in



order to optimally form an annular cement liner and radially expand the tubular member 200.

The second passage 265 is fluidically coupled to the first passage 260 and the chamber 310. The second passage 265 is preferably adapted to
5 controllably convey fluidic materials from the first passage 260 to the chamber 310. In this manner, surge pressures during placement of the apparatus 200 within the wellbore 100 are optimally minimized. The second passage 265 further includes a valve for controlling the flow of fluidic materials through the second passage 265.

10 The third passage 270 is fluidically coupled to the first passage 260 and the annular chamber 300. The third passage 270 is preferably adapted to convey fluidic materials between the first passage 260 and the annular chamber 300. In this manner, the annular chamber 300 is optimally pressurized.

15 The fourth passage 275 is fluidically coupled to the first passage 260, the fifth passage 285, and the chamber 310. The fourth passage 275 is preferably adapted to convey fluidic materials between the fifth passage 285 and the chamber 310. In this manner, during the radial expansion of the tubular member 200, fluidic materials from the chamber 305 are transmitted to the
20 chamber 310. The fourth passage 275 further includes a pressure compensated valve and/or a pressure compensated orifice in order to optimally control the flow of fluidic materials through the fourth passage 275.

The throat 280 is fluidically coupled to the first passage 260 and the fifth passage 285. The throat 280 is preferably adapted to receive a conventional
25 fluidic plug or ball. In this manner, the first passage 260 is fluidically isolated from the fifth passage 285.

The fifth passage 285 is fluidically coupled to the throat 280, the fourth passage 275, and the chamber 305. The fifth passage 285 is preferably adapted to convey fluidic materials to and from the first passage 260, the
30 fourth passage 275, and the chamber 305.

The sixth passage 290 is fluidically coupled to the chamber 305 and the seventh passage 295. The sixth passage is preferably adapted to convey fluidic materials to and from the chamber 305. The sixth passage 290 is further preferably adapted to receive a conventional plug or dart. In this
5 manner, the chamber 305 is optimally fluidically isolated from the chamber 315.

The seventh passage 295 is fluidically coupled to the sixth passage 290 and the chamber 315. The seventh passage 295 is preferably adapted to convey fluidic materials between the sixth passage 290 and the chamber 315.

The annular chamber 300 is fluidically coupled to the third passage 270.
10 Pressurization of the annular chamber 300 preferably causes the expansion cone 230 to be displaced in the axial direction. In this manner, the tubular member 200 is radially expanded by the expansion cone 230. During operation of the apparatus 200, the annular chamber 300 is preferably adapted to be pressurized to operating pressures ranging from about 1000 to
15 10000 psi (68.95 to 689.48 bar) in order to optimally radially expand the tubular member 200.

The chamber 305 is fluidically coupled to the fifth passage 285 and the sixth passage 290. During operation of the apparatus 200, the chamber 305 is preferably fluidically isolated from the annular chamber 300 and the chamber
20 315 and fluidically coupled to the chamber 310.

The chamber 310 is fluidically coupled to the fourth passage 275. During operation of the apparatus 200, the chamber 310 is preferably fluidically isolated from the annular chamber 300 and fluidically coupled to the chamber 305.

25 During operation, as illustrated in FIG. 1A, the apparatus 200 is preferably placed within the wellbore 100 in a predetermined overlapping relationship with the preexisting casing 115. During placement of the apparatus 200 within the wellbore 100, fluidic materials within the chamber 315 are preferably conveyed to the chamber 310 using the second, first, fifth,
30 sixth and seventh fluid passages 265, 260, 285, 290 and 295, respectively. In this manner, surge pressures within the wellbore 100 during placement of the



apparatus 200 are minimized. Once the apparatus 200 has been placed at the predetermined location within the wellbore 100, the second passage 265 is preferably closed using a conventional valve member.

As illustrated in FIG. 1B, one or more volumes of a non-hardenable fluidic material are then injected into the chamber 315 using the first, fifth, sixth and seventh passages, 260, 285, 290 and 295 in order to ensure that all of the passages are clear. A quantity of a hardenable fluidic sealing material such as, for example, cement, is then preferably injected into the chamber 315 using the first, fifth, sixth and seventh passages 260, 285, 290 and 295. In this manner, an annular outer sealing layer is preferably formed around the radially expanded tubular member 200.

As illustrated in FIG. 1C, a conventional wiper plug 320 is then preferably injected into the first passage 260 using a non-hardenable fluidic material. The wiper plug 320 preferably passes through the first and fifth passages, 260 and 285, and into the chamber 305. Inside the chamber 305, the wiper plug 320 preferably forces substantially all of the hardenable fluidic material out of the chamber 305 through the sixth passage 290. The wiper plug 320 then preferably lodges in and fluidically seals off the sixth passage 290. In this manner, the chamber 305 is optimally fluidically isolated from the chamber 315. Furthermore, the amount of hardenable sealing material within the chamber 305 is minimized.

As illustrated in FIG. 1D, a conventional sealing ball or plug 325 is then preferably injected into the first passage 260 using a non-hardenable fluidic material. The sealing ball 325 preferably lodges in and fluidically seals off the throat 280. In this manner, the first passage 260 is fluidically isolated from the fifth fluid passage 285. Consequently, the injected non-hardenable fluidic sealing material passes from the first passage 260 into the third passage 270 and into the annular chamber 300. In this manner, the annular chamber 300 is pressurized.

As illustrated in FIG. 1E, continued injection of a non-hardenable fluidic material into the annular chamber 300 preferably increases the

operating pressure within the annular chamber 300, and thereby causes the expansion cone 230 to move in the axial direction. The axial movement of the expansion cone 230 radially expands the tubular member 200. The annular chamber 300 is pressurized to operating pressures ranging from about 1000 to 5 10000 psi (68.95 to 689.48 bar). during the radial expansion process. The pressure differential between the first passage 260 and the fifth passage 285 is maintained at least about 1000 to 10000 psi (68.95 to 689.48 bar). during the radial expansion process in order to optimally fluidically seal the throat 280 using the sealing ball 325.

10 During the axial movement of the expansion cone 230, at least a portion of the interface between the expansion cone 230 and the tubular member 200 is fluidically sealed by the sealing members 240a and 240b. During the axial movement of the expansion cone 230, at least a portion of the interface between the expansion cone 230 and the second support member 215 is 15 fluidically sealed by the sealing members 245a, 245b and 240c. In this manner, the annular chamber 300 is optimally fluidically isolated from the chamber 305 during the radial expansion process.

During the radial expansion process, the volumetric size of the annular chamber 300 preferably increases while the volumetric size of the chamber 20 305 preferably decreases during the radial expansion process. During the radial expansion process, fluidic materials within the decreasing chamber 305 are transmitted to the chamber 310 using the fourth and fifth passages, 275 and 285. In this manner, the rate and amount of axial movement of the expansion cone 230 is optimally controlled by the flow rate of fluidic materials 25 conveyed from the chamber 300 to the chamber 310. The fourth passage 275 further includes a conventional pressure compensated valve in order to optimally control the initiation of the radial expansion process. The fourth passage 275 further includes a conventional pressure compensated orifice in order to optimally control the rate of the radial expansion process.

30 Continued radial expansion of the tubular member 200 by the expansion cone 230 causes the sealing members 250 to contact the inside

surface of the existing casing 115. In this manner, the interface between the radially expanded tubular member 200 and the preexisting casing 115 is optimally fluidically sealed. Furthermore, continued radial expansion of the tubular member 200 by the expansion cone 230 causes the anchor 255 to
5 contact and at least partially penetrate the inside surface of the preexisting casing 115. In this manner, the radially expanded tubular member 200 is optimally coupled to the preexisting casing 115.

As illustrated in FIG. 1F, upon the completion of the radial expansion process using the apparatus 200 and the curing of the hardenable fluidic
10 sealing material, a new section of wellbore casing is generated that preferably includes the radially expanded tubular member 200 and an outer annular fluidic sealing member 330. In this manner, a new section of wellbore casing is generated by radially expanding a tubular member into contact with a preexisting section of wellbore casing. In several alternative preferred
15 embodiments, the apparatus 200 is used to form or repair a wellbore casing, a pipeline, or a structural support.

Referring now to FIGS. 2A-2O, and 3A-3J, an apparatus 500 for forming or repairing a wellbore casing, pipeline or structural support will be described. The apparatus 500 preferably includes a first support member 505,
20 a debris shield 510, a second support member 515, one or more crossover valve members 520, a force multiplier outer support member 525, a force multiplier inner support member 530, a force multiplier piston 535, a force multiplier sleeve 540, a first coupling 545, a third support member 550, a spring spacer 555, a preload spring 560, a lubrication fitting 565, a lubrication packer sleeve
25 570, a body of lubricant 575, a mandrel 580, an expansion cone 585, a centralizer 590, a liner hanger 595, a travel port sealing sleeve 600, a second coupling 605, a collet mandrel 610, a load transfer sleeve 615, one or more locking dogs 620, a locking dog retainer 622, a collet assembly 625, a collet retaining sleeve 635, a collet retaining adapter 640, an outer collet support
30 member 645, a liner hanger setting sleeve 650, one or more crossover valve shear pins 655, one or more set screws 660, one or more collet retaining sleeve

shear pins 665, a first passage 670, one or more second passages 675, a third passage 680, one or more crossover valve chambers 685, a primary throat passage 690, a secondary throat passage 695, a fourth passage 700, one or more inner crossover ports 705, one or more outer crossover ports 710, a force multiplier piston chamber 715, a force multiplier exhaust chamber 720, one or more force multiplier exhaust passages 725, a second annular chamber 735, one or more expansion cone travel indicator ports 740, one or more collet release ports 745, a third annular chamber 750, a collet release throat passage 755, a fifth passage 760, one or more sixth passages 765, one or more seventh passages 770, one or more collet sleeve passages 775, one or more force multiplier supply passages 790, a first lubrication supply passage 795, a second lubrication supply passage 800, and a collet sleeve release chamber 805.

The first support member 505 is coupled to the debris shield 510 and the second support member 515. The first support member 505 includes the first passage 670 and the second passages 675 for conveying fluidic materials. The first support member 505 preferably has a substantially annular cross section. The first support member 505 may be fabricated from any number of conventional commercially available materials. The first support member 505 is fabricated from alloy steel having a minimum yield strength ranging from about 75,000 to 140,000 psi (5,171.07 to 9,652.66 bar) in order to optimally provide high strength and resistance to abrasion and fluid erosion. The first support member 505 preferably further includes a first end 1005, a second end 1010, a first threaded portion 1015, a sealing member 1020, a second threaded portion 1025, and a collar 1035.

The first end 1005 of the first support member 505 preferably includes the first threaded portion 1015 and the first passage 670. The first threaded portion 1015 is preferably adapted to be removably coupled to a conventional support member. The first threaded portion 1015 may include any number of conventional commercially available threads. The first threaded portion 1015

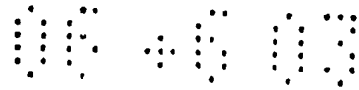

is a 4½" (11.43 centimetres) API IF box threaded portion in order to optimally provide high tensile strength.

The second end 1010 of the first support member 505 is preferably adapted to extend within both the debris shield 510 and the second support member 515. The second end 1010 of the first support member 505 preferably includes the sealing member 1020, the second threaded portion 1025, the first passage 670, and the second passages 675. The sealing member 1020 is preferably adapted to fluidically seal the interface between first support member 505 and the second support member 515. The sealing member 1020 may comprise any number of conventional commercially available sealing members. The sealing member 1020 is an O-ring sealing member available from Parker Seals in order to optimally provide a fluidic seal. The second threaded portion 1025 is preferably adapted to be removably coupled to the second support member 515. The second threaded portion 1025 may comprise any number of conventional commercially available threaded portions. The second threaded portion 1025 is a stub acme thread available from Halliburton Energy Services in order to optimally provide high tensile strength. The second end 1010 of the first support member 505 includes a plurality of the passages 675 in order to optimally provide a large flow cross sectional area. The collar 1035 preferably extends from the second end 1010 of the first support member 505 in an outward radial direction. In this manner, the collar 1035 provides a mounting support for the debris shield 510.

The debris shield 510 is coupled to the first support member 505. The debris shield 510 preferably prevents foreign debris from entering the passage 680. In this manner, the operation of the apparatus 200 is optimized. The debris shield 510 preferably has a substantially annular cross section. The debris shield 510 may be fabricated from any number of conventional commercially available materials. The debris shield 510 is fabricated from alloy steel having a minimum yield strength ranging from about 75,000 to 140,000 psi (5,171.07 to 9,652.66 bar) in order to optimally provide resistance

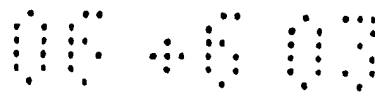

to erosion. The debris shield 510 further preferably includes a first end 1040, a second end 1045, a channel 1050, and a sealing member 1055.

The first end 1040 of the debris shield 510 is preferably positioned above both the outer surface of the second end 1010 of the first support member 505 and the second passages 675 and below the inner surface of the second support member 515. In this manner, fluidic materials from the passages 675 flow from the passages 675 to the passage 680. Furthermore, the first end 1040 of the debris shield 510 also preferably prevents the entry of foreign materials into the passage 680.

10 The second end 1045 of the debris shield 510 preferably includes the channel 1050 and the sealing member 1055. The channel 1050 of the second end 1045 of the debris shield 510 is preferably adapted to mate with and couple to the collar 1035 of the second end 1010 of the first support member 505. The sealing member 1055 is preferably adapted to seal the interface
15 between the second end 1010 of the first support member 505 and the second end 1045 of the debris shield 510. The sealing member 1055 may comprise any number of conventional commercially available sealing members. The sealing member 1055 is an O-ring sealing member available from Parker Seals in order to optimally provide a fluidic seal.

20 The second support member 515 is coupled to the first support member 505, the force multiplier outer support member 525, the force multiplier inner support member 530, and the crossover valve shear pins 655. The second support member 515 is movably coupled to the crossover valve members 520. The second support member 515 preferably has a substantially annular cross
25 section. The second support member 515 may be fabricated from any number of conventional commercially available materials. The second support member 515 is fabricated from alloy steel having a minimum yield strength ranging from about 75,000 to 140,000 psi (5,171.07 to 9,652.66 bar) in order to optimally provide high strength and resistance to abrasion and fluid erosion.

30 The second support member 515 preferably further includes a first end 1060, an intermediate portion 1065, a second end 1070, a first threaded portion

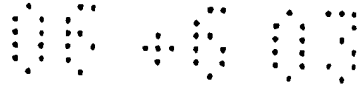

1075, a second threaded portion 1080, a third threaded portion 1085, a first sealing member 1090, a second sealing member 1095, and a third sealing member 1100.

5 The first end 1060 of the second support member 515 is preferably adapted to contain the second end 1010 of the first support member 505 and the debris shield 510. The first end 1060 of the second support member 515 preferably includes the third passage 680 and the first threaded portion 1075. The first threaded portion 1075 of the first end 1060 of the second support member 515 is preferably adapted to be removably coupled to the second
10 threaded portion 1025 of the second end 1010 of the first support member 505. The first threaded portion 1075 may include any number of conventional commercially available threaded portions. The first threaded portion 1075 is a stub acme thread available from Halliburton Energy Services in order to optimally provide high tensile strength.

15 The intermediate portion 1065 of the second support member 515 preferably includes the crossover valve members 520, the crossover valve shear pins 655, the crossover valve chambers 685, the primary throat passage 690, the secondary throat passage 695, the fourth passage 700, the seventh passages 770, the force multiplier supply passages 790, the second threaded
20 portion 1080, the first sealing member 1090, and the second sealing member 1095. The second threaded portion 1080 is preferably adapted to be removably coupled to the force multiplier outer support member 525. The second threaded portion 1080 may include any number of conventional commercially available threaded portions. The second threaded portion 1080
25 is a stub acme thread available from Halliburton Energy Services in order to optimally provide high tensile strength. The first and second sealing members, 1090 and 1095, are preferably adapted to fluidically seal the interface between the intermediate portion 1065 of the second support member 515 and the force multiplier outer support member 525.

30 The second end 1070 of the second support member 515 preferably includes the fourth passage 700, the third threaded portion 1085, and the

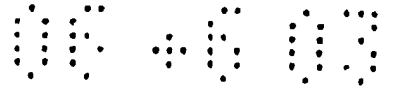

third sealing member 1100. The third threaded portion 1085 of the second end 1070 of the second support member 515 is preferably adapted to be removably coupled to the force multiplier inner support member 530. The third threaded portion 1085 may include any number of conventional
5 commercially available threaded portions. The third threaded portion 1085 is a stub acme thread available from Halliburton Energy Services in order to optimally provide high tensile strength. The third sealing member 1100 is preferably adapted to fluidically seal the interface between the second end 1070 of the second support member 515 and the force multiplier inner support
10 member 530. The third sealing member 1100 may comprise any number of conventional commercially available sealing members. The third sealing member 1100 is an o-ring sealing member available from Parker Seals in order to optimally provide a fluidic seal.

Each crossover valve member 520 is coupled to corresponding crossover
15 valve shear pins 655. Each crossover valve member 520 is also movably coupled to the second support member 515 and contained within a corresponding crossover valve chamber 685. Each crossover valve member 520 preferably has a substantially circular cross-section. The crossover valve members 520 may be fabricated from any number of conventional
20 commercially available materials. The crossover valve members 520 are fabricated from alloy steel having a minimum yield strength ranging from about 75,000 to 140,000 psi (5,171.07 to 9,652.66 bar) in order to optimally provide high strength and resistance to abrasion and fluid erosion. Each crossover valve member 520 includes a first end 1105, an intermediate portion
25 1110, a second end 1115, a first sealing member 1120, a second sealing member 1125, and recesses 1130.

The first end 1105 of the crossover valve member 520 preferably includes the first sealing member 1120. The outside diameter of the first end 1105 of the crossover valve member 520 is preferably less than the inside
30 diameter of the corresponding crossover valve chamber 685 in order to provide a sliding fit. The outside diameter of the first end 1105 of the crossover valve

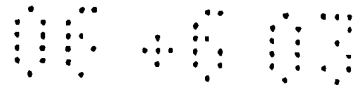

member 520 is preferably about 0.005 to 0.010 inches (0.0127 to 0.254 centimetres) less than the inside diameter of the corresponding crossover valve chamber 685 in order to provide an optimal sliding fit. The first sealing member 1120 is preferably adapted to fluidically seal the dynamic interface
5 between the first end 1105 of the crossover valve member 520 and the corresponding crossover valve chamber 685. The first sealing member 1120 may include any number of conventional commercially available sealing members. The first sealing member 1120 is an o-ring sealing member available from Parker Seals in order to optimally provide a dynamic fluidic
10 seal.

The intermediate end 1110 of the crossover valve member 520 preferably has an outside diameter that is less than the outside diameters of the first and second ends, 1105 and 1115, of the crossover valve member 520. In this manner, fluidic materials are optimally conveyed from the
15 corresponding inner crossover port 705 to the corresponding outer crossover ports 710 during operation of the apparatus 200.

The second end 1115 of the crossover valve member 520 preferably includes the second sealing member 1125 and the recesses 1130. The outside diameter of the second end 1115 of the crossover valve member 520 is
20 preferably less than the inside diameter of the corresponding crossover valve chamber 685 in order to provide a sliding fit. The outside diameter of the second end 1115 of the crossover valve member 520 is preferably about 0.005 to 0.010 inches (0.0127 to 0.254 centimetres) less than the inside diameter of the corresponding crossover valve chamber 685 in order to provide an optimal
25 sliding fit. The second sealing member 1125 is preferably adapted to fluidically seal the dynamic interface between the second end 1115 of the crossover valve member 520 and the corresponding crossover valve chamber 685. The second sealing member 1125 may include any number of conventional commercially available sealing members. The second sealing member 1125 is an o-ring
30 sealing member available from Parker Seals in order to optimally provide a dynamic fluidic seal. The recesses 1130 are preferably adapted to receive the

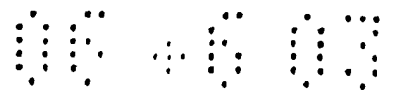

corresponding crossover valve shear pins 655. In this manner, the crossover valve member 520 is maintained in a substantially stationary position.

The force multiplier outer support member 525 is coupled to the second support member 515 and the liner hanger 595. The force multiplier outer support member 525 preferably has a substantially annular cross section. The force multiplier outer support member 525 may be fabricated from any number of conventional commercially available materials. The force multiplier outer support member 525 is fabricated from alloy steel having a minimum yield strength ranging from about 75,000 to 140,000 psi (5,171.07 to 9,652.66 bar) in order to optimally provide high strength and resistance to abrasion and fluid erosion. The force multiplier outer support member 525 preferably further includes a first end 1135, a second end 1140, a first threaded portion 1145, and a sealing member 1150.

The first end 1135 of the force multiplier outer support member 525 preferably includes the first threaded portion 1145 and the force multiplier piston chamber 715. The first threaded portion 1145 is preferably adapted to be removably coupled to the second threaded portion 1080 of the intermediate portion 1065 of the second support member 515. The first threaded portion 1145 may include any number of conventional commercially available threads. The first threaded portion 1145 is a stub acme thread in order to optimally provide high tensile strength.

The second end 1140 of the force multiplier outer support member 525 is preferably adapted to extend within at least a portion of the liner hanger 595. The second end 1140 of the force multiplier outer support member 525 preferably includes the sealing member 1150 and the force multiplier piston chamber 715. The sealing member 1150 is preferably adapted to fluidically seal the interface between the second end 1140 of the force multiplier outer support member 525 and the liner hanger 595. The sealing member 1150 may comprise any number of conventional commercially available sealing members. The sealing member 1150 is an o-ring with seal backups available from Parker Seals in order to optimally provide a fluidic seal.

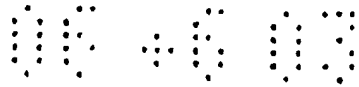

The force multiplier inner support member 530 is coupled to the second support member 515 and the first coupling 545. The force multiplier inner support member 530 is movably coupled to the force multiplier piston 535. The force multiplier inner support member 530 preferably has a substantially
5 annular cross-section. The force multiplier inner support member 530 may be fabricated from any number of conventional commercially available materials. The force multiplier inner support member 530 is fabricated from alloy steel having a minimum yield strength ranging from about 75,000 to 140,000 psi (5,171.07 to 9,652.66 bar) in order to optimally provide high strength and
10 resistance to abrasion and fluid erosion. The outer surface of the force multiplier inner support member 530 includes a nickel plating in order to provide an optimal dynamic seal with the force multiplier piston 535. The force multiplier inner support member 530 further includes a first end 1155, a second end 1160, a first threaded portion 1165, and a second threaded portion
15 1170.

The first end 1155 of the force multiplier inner support member 530 preferably includes the first threaded portion 1165 and the fourth passage 700. The first threaded portion 1165 of the first end 1155 of the force multiplier inner support member 530 is preferably adapted to be removably
20 coupled to the third threaded portion 1085 of the second end 1070 of the second support member 515. The first threaded portion 1165 may comprise any number of conventional commercially available threaded portions. The first threaded portion 1165 is a stub acme thread available from Halliburton Energy Services in order to optimally provide high tensile strength.

25 The second end 1160 of the force multiplier inner support member 530 preferably includes the second threaded portion 1170, the fourth passage 700, and the force multiplier exhaust passages 725. The second threaded portion 1170 of the second end 1160 of the force multiplier inner support member 530 is preferably adapted to be removably coupled to the first coupling 545. The
30 second threaded portion 1170 may comprise any number of conventional commercially available threaded portions. The second threaded portion 1170

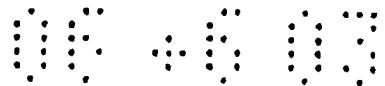

is a stub acme thread available from Halliburton Energy Services in order to optimally provide high tensile strength.

The force multiplier piston 535 is coupled to the force multiplier sleeve 540. The force multiplier piston 535 is movably coupled to the force multiplier inner support member 530. The force multiplier piston 535 preferably has a substantially annular cross-section. The force multiplier piston 535 may be fabricated from any number of conventional commercially available materials. The force multiplier piston 535 is fabricated from alloy steel having a minimum yield strength ranging from about 75,000 to 140,000 psi (5,171.07 to 9,652.66 bar) in order to optimally provide high strength and resistance to abrasion and fluid erosion. The force multiplier piston 535 further includes a first end 1175, a second end 1180, a first sealing member 1185, a first threaded portion 1190, and a second sealing member 1195.

The first end 1175 of the force multiplier piston 535 preferably includes the first sealing member 1185. The first sealing member 1185 is preferably adapted to fluidically seal the dynamic interface between the inside surface of the force multiplier piston 535 and the outside surface of the inner force multiplier support member 530. The first sealing member 1185 may include any number of conventional commercially available sealing members. The first sealing member 1185 is an o-ring with seal backups available from Parker Seals in order to optimally provide a dynamic seal.

The second end 1180 of the force multiplier piston 535 preferably includes the first threaded portion 1190 and the second sealing member 1195. The first threaded portion 1190 is preferably adapted to be removably coupled to the force multiplier sleeve 540. The first threaded portion 1190 may include any number of conventional commercially available threaded portions. The first threaded portion 1190 is a stub acme thread available from Halliburton Energy Services in order to optimally provide high tensile strength. The second sealing member 1195 is preferably adapted to fluidically seal the interface between the second end 1180 of the force multiplier piston 535 and the force multiplier sleeve 540. The second sealing member 1195

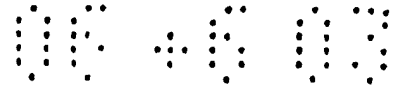

may include any number of conventional commercially available sealing members. The second sealing member 1195 is an o-ring sealing member available from Parker Seals in order to optimally provide a fluidic seal.

The force multiplier sleeve 540 is coupled to the force multiplier piston
5 535. The force multiplier sleeve 540 is movably coupled to the first coupling
545. The force multiplier sleeve 540 preferably has a substantially annular
cross-section. The force multiplier sleeve 540 may be fabricated from any
number of conventional commercially available materials. The force
multiplier sleeve 540 is fabricated from alloy steel having a minimum yield
10 strength ranging from about 75,000 to 140,000 psi (5,171.07 to 9,652.66 bar)
in order to optimally provide high strength and resistance to abrasion and
fluid erosion. The inner surface of the force multiplier sleeve 540 includes a
nickel plating in order to provide an optimal dynamic seal with the outside
surface of the first coupling 545. The force multiplier sleeve 540 further
15 includes a first end 1200, a second end 1205, and a first threaded portion
1210.

The first end 1200 of the force multiplier sleeve 540 preferably includes
the first threaded portion 1210. The first threaded portion 1210 of the first
end 1200 of the force multiplier sleeve 540 is preferably adapted to be
20 removably coupled to the first threaded portion 1190 of the second end 1180 of
the force multiplier piston 535. The first threaded portion 1210 may comprise
any number of conventional commercially available threaded portions.
The first threaded portion 1210 is a stub acme thread available from
Halliburton Energy Services in order to optimally provide high tensile
25 strength.

The first coupling 545 is coupled to the force multiplier inner support
member 530 and the third support member 550. The first coupling 545 is
movably coupled to the force multiplier sleeve 540. The first coupling 545
preferably has a substantially annular cross-section. The first coupling 545
30 may be fabricated from any number of conventional commercially available
materials. The first coupling 545 is fabricated from alloy steel having a

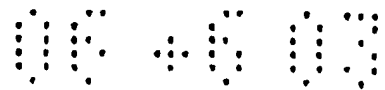

minimum yield strength ranging from about 75,000 to 140,000 psi (5,171.07 to 9,652.66 bar) in order to optimally provide high strength and resistance to abrasion and fluid erosion. The first coupling 545 further includes the fourth passage 700, a first end 1215, a second end 1220, a first inner sealing member
5 1225, a first outer sealing member 1230, a first threaded portion 1235, a second inner sealing member 1240, a second outer sealing member 1245, and a second threaded portion 1250.

The first end 1215 of the first coupling 545 preferably includes the first inner sealing member 1225, the first outer sealing member 1230, and the first
10 threaded portion 1235. The first inner sealing member 1225 is preferably adapted to fluidically seal the interface between the first end 1215 of the first coupling 545 and the second end 1160 of the force multiplier inner support member 530. The first inner sealing member 1225 may include any number of conventional commercially available sealing members. The first inner
15 sealing member 1225 is an o-ring seal available from Parker Seals in order to optimally provide a fluidic seal. The first outer sealing member 1230 is preferably adapted to prevent foreign materials from entering the interface between the first end 1215 of the first coupling 545 and the second end 1205 of the force multiplier sleeve 540. The first outer sealing member 1230 is
20 further preferably adapted to fluidically seal the interface between the first end 1215 of the first coupling 545 and the second end 1205 of the force multiplier sleeve 540. The first outer sealing member 1230 may include any number of conventional commercially available sealing members. The first outer sealing member 1230 is a seal backup available from Parker Seals in order to
25 optimally provide a barrier to foreign materials. The first threaded portion 1235 of the first end 1215 of the first coupling 545 is preferably adapted to be removably coupled to the second threaded portion 1170 of the second end 1160 of the force multiplier inner support member 530. The first threaded portion 1235 may comprise any number of conventional commercially available
30 threaded portions. The first threaded portion 1235 is a stub acme thread

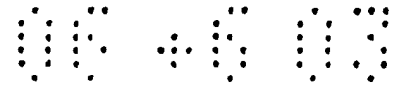

available from Halliburton Energy Services in order to optimally provide high tensile strength.

The second end 1220 of the first coupling 545 preferably includes the second inner sealing member 1240, the second outer sealing member 1245, 5 and the second threaded portion 1250. The second inner sealing member 1240 is preferably adapted to fluidically seal the interface between the second end 1220 of the first coupling 545 and the third support member 550. The second inner sealing member 1240 may include any number of conventional commercially available sealing members. The second inner sealing member 10 1240 is an o-ring available from Parker Seals in order to optimally provide a fluidic seal. The second outer sealing member 1245 is preferably adapted to fluidically seal the dynamic interface between the second end 1220 of the first coupling 545 and the second end 1205 of the force multiplier sleeve 540. The second outer sealing member 1245 may include any number of conventional 15 commercially available sealing members. The second outer sealing member 1245 is an o-ring with seal backups available from Parker Seals in order to optimally provide a fluidic seal. The second threaded portion 1250 of the second end 1220 of the first coupling 545 is preferably adapted to be removably coupled to the third support member 550. The second threaded 20 portion 1250 may comprise any number of conventional commercially available threaded portions. The second threaded portion 1250 is a stub acme thread available from Halliburton Energy Services in order to optimally provide high tensile strength.

The third support member 550 is coupled to the first coupling 545 and 25 the second coupling 605. The third support member 550 is movably coupled to the spring spacer 555, the preload spring 560, the mandrel 580, and the travel port sealing sleeve 600. The third support member 550 preferably has a substantially annular cross-section. The third support member 550 may be fabricated from any number of conventional commercially available materials. 30 The third support member 550 is fabricated from alloy steel having a minimum yield strength ranging from about 75,000 to 140,000 psi (5,171.07 to

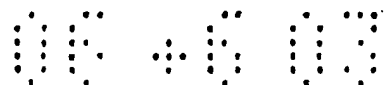

9,652.66 bar) in order to optimally provide high strength and resistance to abrasion and fluid erosion. The outer surface of the third support member 550 includes a nickel plating in order to provide an optimal dynamic seal with the inside surfaces of the mandrel 580 and the travel port sealing sleeve 600. The
5 third support member 550 further includes a first end 1255, a second end 1260, a first threaded portion 1265, and a second threaded portion 1270.

The first end 1255 of the third support member 550 preferably includes the first threaded portion 1265 and the fourth passage 700. The first threaded portion 1265 of the first end 1255 of the third support member 550 is
10 preferably adapted to be removably coupled to the second threaded portion 1250 of the second end 1220 of the first coupling 545. The first threaded portion 1265 may comprise any number of conventional commercially available threaded portions. The first threaded portion 1265 is a stub acme thread available from Halliburton Energy Services in order to optimally
15 provide high tensile strength.

The second end 1260 of the third support member 550 preferably includes the second threaded portion 1270 and the fourth passage 700, and the expansion cone travel indicator ports 740. The second threaded portion 1270 of the second end 1260 of the third support member 550 is preferably
20 adapted to be removably coupled to the second coupling 605. The second threaded portion 1270 may comprise any number of conventional commercially available threaded portions. The second threaded portion 1270 is a stub acme thread available from Halliburton Energy Services in order to optimally provide high tensile strength.

25 The spring spacer 555 is coupled to the preload spring 560. The spring spacer is movably coupled to the third support member 550. The spring spacer 555 preferably has a substantially annular cross-section. The spring spacer 555 may be fabricated from any number of conventional commercially available materials. The spring spacer 555 is fabricated from alloy steel
30 having a minimum yield strength ranging from about 75,000 to 140,000 psi

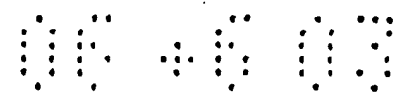

(5,171.07 to 9,652.66 bar) in order to optimally provide high strength and resistance to abrasion and fluid erosion.

The preload spring 560 is coupled to the spring spacer 555. The preload spring 560 is movably coupled to the third support member 550. The preload
5 spring 560 may be fabricated from any number of conventional commercially available materials. The preload spring 560 is fabricated from alloys of chromium-vanadium or chromium-silicon in order to optimally provide a high preload force for sealing the interface between the expansion cone 585 and the liner hanger 595. The preload spring 560 has a spring rate ranging from
10 about 500 to 2000 lbf/in (34.47 to 137.86 bar) in order to optimally provide a preload force.

The lubrication fitting 565 is coupled to the lubrication packer sleeve 570, the body of lubricant 575 and the mandrel 580. The lubrication fitting 565 preferably has a substantially annular cross-section. The lubrication
15 fitting 565 may be fabricated from any number of conventional commercially available materials. The lubrication fitting 565 is fabricated from alloy steel having a minimum yield strength ranging from about 75,000 to 140,000 psi (5,171.07 to 9,652.66 bar) in order to optimally provide high strength and resistance to abrasion and fluid erosion. The lubrication fitting 565 preferably
20 includes a first end 1275, a second end 1280, a lubrication injection fitting 1285, a first threaded portion 1290, and the first lubrication supply passage 795.

The first end 1275 of the lubrication fitting 565 preferably includes the lubrication injection fitting 1285, the first threaded portion 1290 and the first
25 lubrication supply passage 795. The lubrication injection fitting 1285 is preferably adapted to permit lubricants to be injected into the first lubrication supply passage 795. The lubrication injection fitting 1285 may comprise any number of conventional commercially available injection fittings. The lubrication injection fitting 1285 is a model 1641-B grease fitting available
30 from Alemite Corp. in order to optimally provide a connection for injecting lubricants. The first threaded portion 1290 of the first end 1275 of the

lubrication fitting 565 is preferably adapted to be removably coupled to the mandrel 580. The first threaded portion 1290 may comprise any number of conventional commercially available threaded portions. The first threaded portion 1290 is a stub acme thread available from Halliburton Energy Services. The second end 1280 of the lubrication fitting 565 is preferably spaced above the outside surface of the mandrel 580 in order to define a portion of the first lubrication supply passage 795.

The lubrication packer sleeve 570 is coupled to the lubrication fitting 565 and the body of lubricant 575. The lubrication packer sleeve 570 is movably coupled to the liner hanger 595. The lubrication packer sleeve 570 is preferably adapted to fluidically seal the radial gap between the outside surface of the second end 1280 of the lubrication fitting 565 and the inside surface of the liner hanger 595. The lubrication packer sleeve 570 is further preferably adapted to compress the body of lubricant 575. In this manner, the lubricants within the body of lubricant 575 are optimally pumped to outer surface of the expansion cone 585.

The lubrication packer sleeve 570 may comprise any number of conventional commercially available packer sleeves. The lubrication packer sleeve 570 is a 70 durometer packer available from Halliburton Energy Services in order to optimally provide a low pressure fluidic seal.

The body of lubricant 575 is fluidically coupled to the first lubrication supply passage 795 and the second lubrication supply passage 800. The body of lubricant 575 is movably coupled to the lubrication fitting 565, the lubrication packer sleeve 570, the mandrel 580, the expansion cone 585 and the liner hanger 595. The body of lubricant 575 preferably provides a supply of lubricant for lubricating the dynamic interface between the outside surface of the expansion cone 585 and the inside surface of the liner hanger 595. The body of lubricant 575 may include any number of conventional commercially available lubricants. The body of lubricant 575 includes anti-seize 1500 available from Climax Lubricants and Equipment Co. in order to optimally provide high pressure lubrication.

During operation of the apparatus 500, the body of lubricant 575 lubricates the interface between the interior surface of the expanded portion of the liner hanger 595 and the exterior surface of the expansion cone 585. In this manner, when the expansion cone 585 is removed from the interior of the
5 radially expanded liner hanger 595, the body of lubricant 575 lubricates the dynamic interfaces between the interior surface of the expanded portion of the liner hanger 595 and the exterior surface of the expansion cone 585. Thus, the body of lubricant 575 optimally reduces the force required to remove the expansion cone 585 from the radially expanded liner hanger 595.

10 The mandrel 580 is coupled to the lubrication fitting 565, the expansion cone 585, and the centralizer 590. The mandrel 580 is movably coupled to the third support member 550, the body of lubricant 575, and the liner hanger 595. The mandrel 580 preferably has a substantially annular cross-section. The mandrel 580 may be fabricated from any number of conventional
15 commercially available materials. The mandrel 580 is fabricated from alloy steel having a minimum yield strength ranging from about 75,000 to 140,000 psi (5,171.07 to 9,652.66 bar) in order to optimally provide high strength and resistance to abrasion and fluid erosion. The mandrel 580 further includes a first end 1295, an intermediate portion 1300, second end 1305, a first
20 threaded portion 1310, a first sealing member 1315, a second sealing member 1320, and a second threaded portion 1325, a first wear ring 1326, and a second wear ring 1327.

The first end 1295 of the mandrel 580 preferably includes the first threaded portion 1310, the first sealing member 1315, and the first wear ring
25 1326. The first threaded portion 1310 is preferably adapted to be removably coupled to the first threaded portion 1290 of the first end 1275 of the lubrication fitting 565. The first threaded portion 1310 may comprise any number of conventional commercially available threaded portions. The first threaded portion 1310 is a stub acme thread available from Halliburton
30 Energy Services in order to optimally provide high tensile strength. The first sealing member 1315 is preferably adapted to fluidically seal the dynamic

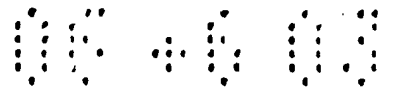

interface between the inside surface of the first end 1295 of the mandrel 580 and the outside surface of the third support member 550. The first sealing member 1315 may comprise any number of conventional commercially available sealing members. The first sealing member 1315 is an o-ring with seal backups available from Parker Seals in order to optimally provide a dynamic fluidic seal. The first wear ring 1326 is preferably positioned within an interior groove formed in the first end 1295 of the mandrel 580. The first wear ring 1326 is preferably adapted to maintain concentricity between and among the mandrel 580 and the third support member 550 during axial displacement of the mandrel 580, reduce frictional forces, and support side loads. The first wear ring 1326 is a model GR2C wear ring available from Busak & Shamban.

The outside diameter of the intermediate portion 1300 of the mandrel 580 is preferably about 0.05 to 0.25 inches (0.127 to 0.635 centimetres) less than the inside diameter of the line hanger 595. In this manner, the second lubrication supply passage 800 is defined by the radial gap between the intermediate portion 1300 of the mandrel 580 and the liner hanger 595.

The second end 1305 of the mandrel 580 preferably includes the second sealing member 1320, the second threaded portion 1325, and the second wear ring 1327. The second sealing member 1320 is preferably adapted to fluidically seal the interface between the inside surface of the expansion cone 585 and the outside surface of the mandrel 580. The second sealing member 1320 may comprise any number of conventional commercially available sealing members. The second sealing member 1320 is an o-ring sealing member available from Parker Seals in order to optimally provide a fluidic seal. The second threaded portion 1325 is preferably adapted to be removably coupled to the centralizer 590. The second threaded portion 1325 may comprise any number of conventional commercially available threaded portions. The second threaded portion 1325 is a stub acme thread available from Halliburton Energy Services in order to optimally provide high tensile strength. The second wear ring 1327 is preferably positioned within an interior groove

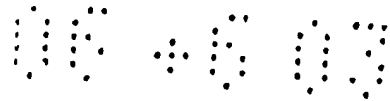

formed in the second end 1305 of the mandrel 580. The second wear ring 1327 is preferably adapted to maintain concentricity between and among the mandrel 580 and the third support member 550 during axial displacement of the mandrel 580, reduce frictional forces, and support side loads. The second
5 wear ring 1327 is a model GR2C wear ring available from Busak & Shamban.

The expansion cone 585 is coupled to the mandrel 580 and the centralizer 590. The expansion cone 585 is fluidically coupled to the second lubrication supply passage 800. The expansion cone 585 is movably coupled to the body of lubricant 575 and the liner hanger 595. The expansion cone 585
10 preferably includes a substantially annular cross-section. The expansion cone 585 may be fabricated from any number of conventional commercially available materials. The expansion cone 585 is fabricated from cold worked tool steel in order to optimally provide high strength and wear resistance.

The expansion cone 585 is further provided substantially as described
15 in one or more of the following: (1) U.S. Patent Application Serial No. 09/440,338, attorney docket number 25791.9.02, filed on 11/15/98, which claimed benefit of the filing date of U.S. Provisional Patent Application Serial Number 60/108,558, attorney docket number 25791.9, filed on 11/16/1998, (2)
20 U.S. Patent Application Serial No.09/454/139, attorney docket number 25791.3.02, filed on 12/3/99, which claimed benefit of the filing date of U.S. Provisional Patent Application Serial Number 60/111,293, filed on 12/7/1998, (3) U.S. Patent Application Serial Number 09/502,350, attorney docket number 25791.8.02, filed on 2/10/00, which claimed the benefit of the filing date of U.S. Provisional Patent Application Serial Number 60/119,611,
25 attorney docket number 25791.8, filed 2/11/1999, (4) U.S. Patent Application Serial Number 09/510,913, attorney docket number 25791.7.02, filed on 2/23/00, which claimed the benefit of the filing date of U.S. Provisional Patent Application Serial Number 60/121,702, attorney docket number 25791.7, filed on 2/25/1999, (5) U.S. Patent Application Serial Number 09/511,941, attorney
30 docket number 25791.16.02, filed on 2/24/00, which claimed the benefit of the filing date of U.S. Provisional Patent Application number 60/121,907, attorney

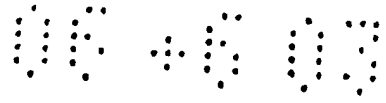

docket number 25791.16, filed 2/26/1999, (6) U.S. Provisional Patent Application Serial Number 60/124,042, attorney docket number 25791.11, filed on 3/11/1999, (7) U.S. Provisional Patent Application Serial Number 60/131,106, attorney docket number 25791.23, filed on 4/26/1999, (8) U.S. Provisional Patent Application Serial Number 60/137,998, attorney docket number 25791.17, filed on 6/7/1999, (9) U.S. Provisional Patent Application Serial Number 60/143,039, attorney docket number 25791.26, filed on 7/9/1999, and (10) U.S. Provisional Patent Application Serial Number 60/146,203, attorney docket number 25791.25, filed on 7/29/1999, the disclosures of which are incorporated by reference.

The centralizer 590 is coupled to the mandrel 580 and the expansion cone 585. The centralizer 590 is movably coupled to the liner hanger 595. The centralizer 590 preferably includes a substantially annular cross-section. The centralizer 590 may be fabricated from any number of conventional commercially available materials. The centralizer 590 is fabricated from alloy steel having a minimum yield strength ranging from about 75,000 to 140,000 in order to optimally provide high strength and resistance to abrasion and fluid erosion. The centralizer 590 preferably includes a first end 1330, a second end 1335, a plurality of centralizer fins 1340, and a threaded portion 1345.

The second end 1335 of the centralizer 590 preferably includes the centralizer fins 1340 and the threaded portion 1345. The centralizer fins 1340 preferably extend from the second end 1335 of the centralizer 590 in a substantially radial direction. The radial gap between the centralizer fins 1340 and the inside surface of the liner hanger 595 is less than about 0.05 to 0.25 inches (0.127 to 0.635 centimetres) in order to optimally provide centralization of the expansion cone 585. The threaded portion 1345 is preferably adapted to be removably coupled to the second threaded portion 1325 of the second end 1305 of the mandrel 580. The threaded portion 1345 may comprise any number of conventional commercially available threaded

portions. The threaded portion 1345 is a stub acme thread in order to optimally provide high tensile strength.

The liner hanger 595 is coupled to the outer collet support member 645 and the set screws 660. The liner hanger 595 is movably coupled to the
5 lubrication packer sleeve 570, the body of lubricant 575, the expansion cone 585, and the centralizer 590. The liner hanger 595 preferably has a substantially annular cross-section. The liner hanger 595 preferably includes a plurality of tubular members coupled end to end. The axial length of the
10 liner hanger 595 preferably ranges from about 5 to 12 feet (1.524 to 3.6576 metres). The liner hanger 595 may be fabricated from any number of conventional commercially available materials. The liner hanger 595 is fabricated from alloy steel having a minimum yield strength ranging from about 40,000 to 125,000 psi (2,757.90 to 8,618.45 bar) in order to optimally provide high strength and ductility. The liner hanger 595 preferably includes
15 a first end 1350, an intermediate portion 1355, a second end 1360, a sealing member 1365, a threaded portion 1370, one or more set screw mounting holes 1375, and one or more outside sealing portions 1380.

The outside diameter of the first end 1350 of the liner hanger 595 is preferably selected to permit the liner hanger 595 and apparatus 500 to be
20 inserted into another opening or tubular member. The outside diameter of the first end 1350 of the liner hanger 595 is selected to be about 0.12 to 2 inches (0.3048 to 5.08 centimetres) less than the inside diameter of the opening or tubular member that the liner hanger 595 will be inserted into. The axial length of the first end 1350 of the liner hanger 595 ranges from about 8 to 20
25 inches (20.32 to 50.8 centimetres).

The outside diameter of the intermediate portion 1355 of the liner hanger 595 preferably provides a transition from the first end 1350 to the second end 1360 of the liner hanger. The axial length of the intermediate portion 1355 of the liner hanger 595 ranges from about 0.25 to 2 inches in
30 order to optimally provide reduced radial expansion pressures.

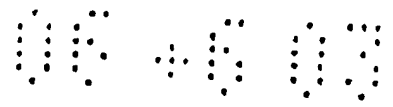

The second end 1360 of the liner hanger 595 includes the sealing member 1365, the threaded portion 1370, the set screw mounting holes 1375 and the outside sealing portions 1380. The outside diameter of the second end 1360 of the liner hanger 595 is preferably about 0.10 to 2 inches (0.254 to 5.08 centimetres) less than the outside diameter of the first end 1350 of the liner hanger 595 in order to optimally provide reduced radial expansion pressures. The sealing member 1365 is preferably adapted to fluidically seal the interface between the second end 1360 of the liner hanger and the outer collet support member 645. The sealing member 1365 may comprise any number of conventional commercially available sealing members. The sealing member 1365 is an o-ring seal available from Parker Seals in order to optimally provide a fluidic seal. The threaded portion 1370 is preferably adapted to be removably coupled to the outer collet support member 645. The threaded portion 1370 may comprise any number of conventional commercially available threaded portions. The threaded portion 1370 is a stub acme thread available from Halliburton Energy Services in order to optimally provide high tensile strength. The set screw mounting holes 1375 are preferably adapted to receive the set screws 660. Each outside sealing portion 1380 preferably includes a top ring 1385, an intermediate sealing member 1395, and a lower ring 1390. The top and bottom rings, 1385 and 1390, are preferably adapted to penetrate the inside surface of a wellbore casing. The top and bottom rings, 1385 and 1390, preferably extend from the outside surface of the second end 1360 of the liner hanger 595. The outside diameter of the top and bottom rings, 1385 and 1390, are less than or equal to the outside diameter of the first end 1350 of the liner hanger 595 in order to optimally provide protection from abrasion when placing the apparatus 500 within a wellbore casing or other tubular member. The top and bottom rings, 1385 and 1390 are fabricated from alloy steel having a minimum yield strength of about 40,000 to 125,000 psi (2,757.90 to 8,618.45 bar) in order to optimally provide high strength and ductility. The top and bottom rings, 1385 and 1390, are integrally formed with the liner hanger 595. The intermediate sealing

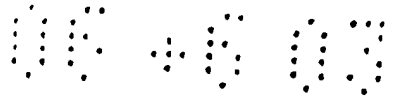

member 1395 is preferably adapted to seal the interface between the outside surface of the second end 1360 of the liner hanger 595 and the inside surface of a wellbore casing. The intermediate sealing member 1395 may comprise any number of conventional sealing members. The intermediate sealing
 5 member 1395 is a 50 to 90 durometer nitrile elastomeric sealing member available from Eutsler Technical Products in order to optimally provide a fluidic seal and shear strength.

The liner hanger 595 is further preferably provided substantially as described in one or more of the following: (1) U.S. Patent Application Serial
 10 No.09/440/338, attorney docket number 25791.9.02, filed on 11/15/98, which claimed benefit of the filing date of U.S. Provisional Patent Application Serial Number 60/108,558, attorney docket number 25791.9, filed on 11/16/1998, (2) U.S. Patent Application Serial No. 09/454,139, attorney docket number 25791.3.02, filed on 12/3/99, which claimed benefit of the filing date of U.S.
 15 Provisional Patent Application Serial Number 60/111,293, filed on 12/7/1998, (3) U.S. Patent Application Serial Number 09/502,350, attorney docket number 25791.8.02, filed on 2/10/00, which claimed the benefit of the filing date of U.S. Provisional Patent Application Serial Number 60/119,611, attorney docket number 25791.8, filed 2/11/1999, (4) U.S. Patent Application
 20 Serial Number 09/510,913, attorney docket number 25791.7.02, filed on 2/23/00, which claimed the benefit of the filing date of U.S. Provisional Patent Application Serial Number 60/121,702, attorney docket number 25791.7, filed on 2/25/1999, (5) U.S. Patent Application Serial Number 09/511,941, attorney docket number 25791.16.02, filed on 2/24/00, which claimed the benefit of the
 25 filing date of U.S. Provisional Patent Application number 60/121,907, attorney docket number 25791.16, filed 2/26/1999, (6) U.S. Provisional Patent Application Serial Number 60/124,042, attorney docket number 25791.11, filed on 3/11/1999, (7) U.S. Provisional Patent Application Serial Number 60/131,106, attorney docket number 25791.23, filed on 4/26/1999, (8) U.S.
 30 Provisional Patent Application Serial Number 60/137,998, attorney docket number 25791.17, filed on 6/7/1999, (9) U.S. Provisional Patent Application

Serial Number 60/143,039, attorney docket number 25791.26, filed on 7/9/1999, and (10) U.S. Provisional Patent Application Serial Number 60/146,203, attorney docket number 25791.25, filed on 7/29/1999, the disclosures of which are incorporated by reference.

5 The travel port sealing sleeve 600 is movably coupled to the third support member 550. The travel port sealing sleeve 600 is further initially positioned over the expansion cone travel indicator ports 740. The travel port sealing sleeve 600 preferably has a substantially annular cross-section. The travel port sealing sleeve 600 may be fabricated from any number of
10 conventional commercially available materials. The travel port sealing sleeve 600 is fabricated from alloy steel having a minimum yield strength of about 75,000 to 140,000 psi (5,171.07 to 9,652.66 bar) in order to optimally provide high strength and resistance to abrasion and fluid erosion. The travel port sealing sleeve preferably includes a plurality of inner sealing members 1400.
15 The inner sealing members 1400 are preferably adapted to seal the dynamic interface between the inside surface of the travel port sealing sleeve 600 and the outside surface of the third support member 550. The inner sealing members 1400 may comprise any number of conventional commercially available sealing members. The inner sealing members 1400 are o-rings
20 available from Parker Seals in order to optimally provide a fluidic seal. The inner sealing members 1400 further provide sufficient frictional force to prevent inadvertent movement of the travel port sealing sleeve 600. In an alternative embodiment, the travel port sealing sleeve 600 is removably coupled to the third support member 550 by one or more shear pins. In this
25 manner, accidental movement of the travel port sealing sleeve 600 is prevented.

The second coupling 605 is coupled to the third support member 550 and the collet mandrel 610. The second coupling 605 preferably has a substantially annular cross-section. The second coupling 605 may be
30 fabricated from any number of conventional commercially available materials. The second coupling 605 is fabricated from alloy steel having a minimum yield

strength of about 75,000 to 140,000 psi (5,171.07 to 9,652.66 bar) in order to optimally provide high strength and resistance to abrasion and fluid erosion. The second coupling 605 further includes the fourth passage 700, a first end 1405, a second end 1410, a first inner sealing member 1415, a first threaded portion 1420, a second inner sealing member 1425, and a second threaded portion 1430.

The first end 1405 of the second coupling 605 preferably includes the first inner sealing member 1415 and the first threaded portion 1420. The first inner sealing member 1415 is preferably adapted to fluidically seal the interface between the first end 1405 of the second coupling 605 and the second end 1260 of the third support member 550. The first inner sealing member 1415 may include any number of conventional commercially available sealing members. The first inner sealing member 1415 is an o-ring available from Parker Seals in order to optimally provide a fluidic seal. The first threaded portion 1420 of the first end 1415 of the second coupling 605 is preferably adapted to be removably coupled to the second threaded portion 1270 of the second end 1260 of the third support member 550. The first threaded portion 1420 may comprise any number of conventional commercially available threaded portions. The first threaded portion 1420 is a stub acme thread available from Halliburton Energy Services in order to optimally provide high tensile strength.

The second end 1410 of the second coupling 605 preferably includes the second inner sealing member 1425 and the second threaded portion 1430. The second inner sealing member 1425 is preferably adapted to fluidically seal the interface between the second end 1410 of the second coupling 605 and the collet mandrel 610. The second inner sealing member 1425 may include any number of conventional commercially available sealing members. The second inner sealing member 1425 is an o-ring available from Parker Seals in order to optimally provide a fluidic seal. The second threaded portion 1430 of the second end 1410 of the second coupling 605 is preferably adapted to be removably coupled to the collet mandrel 610. The second threaded portion

1430 may comprise any number of conventional commercially available threaded portions. The second threaded portion 1430 is a stub acme thread available from Halliburton Energy Services in order to optimally provide high tensile strength.

5 The collet mandrel 610 is coupled to the second coupling 605, the collet retaining adapter 640, and the collet retaining sleeve shear pins 665. The collet mandrel 610 is releasably coupled to the locking dogs 620, the collet assembly 625, and the collet retaining sleeve 635. The collet mandrel 610 preferably has a substantially annular cross-section. The collet mandrel 610
10 may be fabricated from any number of conventional commercially available materials. The collet mandrel 610 is fabricated from alloy steel having a minimum yield strength of about 75,000 to 140,000 psi (5,171.07 to 9,652.66 bar) in order to optimally provide high strength and resistance to abrasion and fluid erosion. The collet mandrel 610 further includes the fourth passage
15 700, the collet release ports 745, the collet release throat passage 755, the fifth passage 760, a first end 1435, a second end 1440, a first shoulder 1445, a second shoulder 1450, a recess 1455, a shear pin mounting hole 1460, a first threaded portion 1465, a second threaded portion 1470, and a sealing member 1475.

20 The first end 1435 of the collet mandrel 610 preferably includes the fourth passage 700, the first shoulder 1445, and the first threaded portion 1465. The first threaded portion 1465 is preferably adapted to be removably coupled to the second threaded portion 1430 of the second end 1410 of the second coupling 605. The first threaded portion 1465 may include any
25 number of conventional threaded portions. The first threaded portion 1465 is a stub acme thread available from Halliburton Energy Services in order to optimally provide high tensile strength.

 The second end 1440 of the collet mandrel 610 preferably includes the fourth passage 700, the collet release ports 745, the collet release throat
30 passage 755, the fifth passage 760, the second shoulder 1450, the recess 1455, the shear pin mounting hole 1460, the second threaded portion 1470, and the

sealing member 1475. The second shoulder 1450 is preferably adapted to mate with and provide a reference position for the collet retaining sleeve 635. The recess 1455 is preferably adapted to define a portion of the collet sleeve release chamber 805. The shear pin mounting hole 1460 is preferably adapted
5 to receive the collet retaining sleeve shear pins 665. The second threaded portion 1470 is preferably adapted to be removably coupled to the collet retaining adapter 640. The second threaded portion 1470 may include any number of conventional commercially available threaded portions. The second threaded portions 1470 is a stub acme thread available from Halliburton
10 Energy Services in order to optimally provide high tensile strength. The sealing member 1475 is preferably adapted to seal the dynamic interface between the outside surface of the collet mandrel 610 and the inside surface of the collet retaining sleeve 635. The sealing member 1475 may include any number of conventional commercially available sealing members. The sealing
15 member 1475 is an o-ring available from Parker Seals in order to optimally provide a fluidic seal.

The load transfer sleeve 615 is movably coupled to the collet mandrel 610, the collet assembly 625, and the outer collet support member 645. The load transfer sleeve 615 preferably has a substantially annular cross-section.
20 The load transfer sleeve 615 may be fabricated from any number of conventional commercially available materials. The load transfer sleeve 615 is fabricated from alloy steel having a minimum yield strength of about 75,000 to 140,000 psi (5,171.07 to 9,652.66 bar) in order to optimally provide high strength and resistance to abrasion and fluid erosion. The load transfer sleeve
25 615 further a first end 1480 and a second end 1485.

The inside diameter of the first end 1480 of the load transfer sleeve 615 is preferably greater than the outside diameter of the collet mandrel 610 and less than the outside diameters of the second coupling 605 and the locking dog retainer 622. In this manner, during operation of the apparatus 500, the load
30 transfer sleeve 615 optimally permits the flow of fluidic materials from the second annular chamber 735 to the third annular chamber 750. Furthermore,

in this manner, during operation of the apparatus 200, the load transfer sleeve 615 optimally limits downward movement of the second coupling 605 relative to the collet assembly 625.

The second end 1485 of the load transfer sleeve 615 is preferably
5 adapted to cooperatively interact with the collet 625. In this manner, during operation of the apparatus 200, the load transfer sleeve 615 optimally limits downward movement of the second coupling 605 relative to the collet assembly 625.

The locking dogs 620 are coupled to the locking dog retainer 622 and
10 the collet assembly 625. The locking dogs 620 are releasably coupled to the collet mandrel 610. The locking dogs 620 are preferably adapted to lock onto the outside surface of the collet mandrel 610 when the collet mandrel 610 is displaced in the downward direction relative to the locking dogs 620. The locking dogs 620 may comprise any number of conventional commercially
15 available locking dogs. The locking dogs 620 include a plurality of locking dog elements 1490 and a plurality of locking dog springs 1495.

Each of the locking dog elements 1490 include an arcuate segment including a pair of external grooves for receiving the locking dog springs.
1495. Each of the locking dog springs 1495 are garter springs. During
20 operation of the apparatus 500, the locking dog elements 1490 are preferably radially inwardly displaced by the locking dog springs 1495 when the locking dogs 620 are relatively axially displaced past the first shoulder 1445 of the collet mandrel 610. As a result, the locking dogs 620 are then engaged by the first shoulder 1445 of the collet mandrel 610.

25 The locking dog retainer 622 is coupled to the locking dogs 620 and the collet assembly 625. The locking dog retainer 622 preferably has a substantially annular cross-section. The locking dog retainer 622 may be fabricated from any number of conventional commercially available materials. The locking dog retainer 622 is fabricated from alloy steel having a minimum
30 yield strength of about 75,000 to 140,000 psi (5,171.07 to 9,652.66 bar) in order to optimally provide high strength and resistance to abrasion and fluid

erosion. The locking dog retainer 622 further includes a first end 1500, a second end 1505, and a threaded portion 1510.

The first end 1500 of the locking dog retainer 622 is preferably adapted to capture the locking dogs 620. In this manner, when the locking dogs 620 latch onto the first shoulder 1445 of the collet mandrel 610, the locking dog retainer 622 transmits the axial force to the collet assembly 625.

The second end 1505 of the locking dog retainer preferably includes the threaded portion 1510. The threaded portion 1510 is preferably adapted to be removably coupled to the collet assembly 625. The threaded portion 1510 may comprise any number of conventional commercially available threaded portions. The threaded portions 1510 is a stub acme thread available from Halliburton Energy Services in order to optimally provide high tensile strength.

The collet assembly 625 is coupled to the locking dogs 620 and the locking dog retainer 622. The collet assembly 625 is releasably coupled to the collet mandrel 610, the outer collet support member 645, the collet retaining sleeve 635, the load transfer sleeve 615, and the collet retaining adapter 640. The collet assembly 625 preferably has a substantially annular cross-section. The collet assembly 625 may be fabricated from any number of conventional commercially available materials. The collet assembly 625 is fabricated from alloy steel having a minimum yield strength of about 75,000 to 140,000 psi (5,171.07 to 9,652.66 bar) in order to optimally provide high strength and resistance to abrasion and fluid erosion. The collet assembly 625 includes a collet body 1515, a plurality of collet arms 1520, a plurality of collet upsets 1525, flow passages 1530, and a threaded portion 1535.

The collet body 1515 preferably includes the flow passages 1530 and the threaded portion 1535. The flow passages 1530 are preferably adapted to convey fluidic materials between the second annular chamber 735 and the third annular chamber 750. The threaded portion 1535 is preferably adapted to be removably coupled to the threaded portion 1510 of the second end 1505 of the locking dog retainer 622. The threaded portion 1535 may include any

number of conventional commercially available threaded portions. The threaded portion 1535 is a stub acme thread available from Halliburton Energy Services in order to optimally provide high tensile strength.

The collet arms 1520 extend from the collet body 1515 in a substantially axial direction. The collet upsets 1525 extend from the ends of corresponding collet arms 1520 in a substantially radial direction. The collet upsets 1525 are preferably adapted to mate with and cooperatively interact with corresponding slots provided in the collet retaining adapter 640 and the liner hanger setting sleeve 650. In this manner, the collet upsets 1525 preferably controllably couple the collet retaining adapter 640 to the outer collet support member 645 and the liner hanger setting sleeve 650. In this manner, axial and radial forces are optimally coupled between the collet retaining adapter 640, the outer collet support member 645 and the liner hanger setting sleeve 650. The collet upsets 1525 preferably include a flat outer surface 1540 and an angled outer surface 1545. In this manner, the collet upsets 1525 are optimally adapted to be removably coupled to the slots provided in the collet retaining adapter 640 and the liner hanger setting sleeve 650.

The collet retaining sleeve 635 is coupled to the collet retaining sleeve shear pins 665. The collet retaining sleeve 635 is movably coupled to the collet mandrel 610 and the collet assembly 625. The collet retaining sleeve 635 preferably has a substantially annular cross-section. The collet retaining sleeve 635 may be fabricated from any number of conventional commercially available materials. The collet retaining sleeve 635 is fabricated from alloy steel having a minimum yield strength of about 75,000 to 140,000 psi (5,171.07 to 9,652.66 bar) in order to optimally provide high strength and resistance to abrasion and fluid erosion. The collet retaining sleeve 635 includes the collet sleeve passages 775, a first end 1550, a second end 1555, one or more shear pin mounting holes 1560, a first shoulder 1570, a second shoulder 1575, and a sealing member 1580.

08 00 00

The first end 1550 of the collet retaining sleeve 635 preferably includes the collet sleeve passages 775, the shear pin mounting holes 1560, and the first shoulder 1570. The collet sleeve passages 775 are preferably adapted to convey fluidic materials between the second annular chamber 735 and the
5 third annular chamber 750. The shear pin mounting holes 1560 are preferable adapted to receive corresponding shear pins 665. The first shoulder 1570 is preferably adapted to mate with the second shoulder 1450 of the collet mandrel 610.

The second end 1555 of the collet retaining sleeve 635 preferably
10 includes the collet sleeve passages 775, the second shoulder 1575, and the sealing member 1580. The collet sleeve passages 775 are preferably adapted to convey fluidic materials between the second annular chamber 735 and the third annular chamber 750. The second shoulder 1575 of the second end 1555 of the collet retaining sleeve 635 and the recess 1455 of the second end 1440 of
15 the collet mandrel 610 are preferably adapted to define the collet sleeve release chamber 805. The sealing member 1580 is preferably adapted to seal the dynamic interface between the outer surface of the collet mandrel 610 and the inside surface of the collet retaining sleeve 635. The sealing member 1580 may include any number of conventional commercially available sealing
20 members. The sealing member 1580 is an o-ring available from Parker Seals in order to optimally provide a fluidic seal.

The collet retaining adapter 640 is coupled to the collet mandrel 610. The collet retaining adapter 640 is movably coupled to the liner hanger setting sleeve 650, the collet retaining sleeve 635, and the collet assembly 625.
25 The collet retaining adapter 640 preferably has a substantially annular cross-section. The collet retaining adapter 640 may be fabricated from any number of conventional commercially available materials. The collet retaining adapter 640 is fabricated from alloy steel having a minimum yield strength of about 75,000 to 140,000 psi (5,171.07 to 9,652.66 bar) in order to optimally
30 provide high strength and resistance to abrasion and fluid erosion. The collet retaining adapter 640 includes the fifth passage 760, the sixth passages 765, a

first end 1585, an intermediate portion 1590, a second end 1595, a plurality of collet slots 1600, a sealing member 1605, a first threaded portion 1610, and a second threaded portion 1615.

The first end 1585 of the collet retaining adapter 640 preferably
5 includes the collet slots 1600. The collet slots 1600 are preferably adapted to cooperatively interact with and mate with the collet upsets 1525. The collet slots 1600 are further preferably adapted to be substantially aligned with corresponding collet slots provided in the liner hanger setting sleeve 650. In this manner, the slots provided in the collet retaining adapter 640 and the
10 liner hanger setting sleeve 650 are removably coupled to the collet upsets 1525.

The intermediate portion 1590 of the collet retaining adapter 640 preferably includes the sixth passages 765, the sealing member 1605, and the first threaded portion 1610. The sealing member 1605 is preferably adapted
15 to fluidically seal the interface between the outside surface of the collet retaining adapter 640 and the inside surface of the liner hanger setting sleeve 650. The sealing member 1605 may include any number of conventional commercially available sealing members. The sealing member 1605 is an o-ring available from Parker Seals in order to optimally provide a fluidic seal.
20 The first threaded portion 1610 is preferably adapted to be removably coupled to the second threaded portion 1470 of the second end 1440 of the collet mandrel 610. The first threaded portion 1610 may include any number of conventional commercially available threaded portions. The first threaded portion 1610 is a stub acme thread available from Halliburton Energy
25 Services in order to optimally provide high tensile strength.

The second end 1595 of the collet retaining adapter 640 preferably includes the fifth passage 760 and the second threaded portion 1615. The second threaded portion 1615 is preferably adapted to be removably coupled to a conventional SSR plug set, or other similar device.

30 The outer collet support member 645 is coupled to the liner hanger 595, the set screws 660, and the liner hanger setting sleeve 650. The outer collet

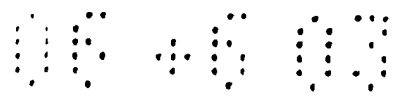

support member 645 is releasably coupled to the collet assembly 625. The outer collet support member 645 is movably coupled to the load transfer sleeve 615. The outer collet support member 645 preferably has a substantially annular cross-section. The outer collet support member 645 may be fabricated
5 from any number of conventional commercially available materials. The outer collet support member 645 is fabricated from alloy steel having a minimum yield strength of about 75,000 to 140,000 psi (5,171.07 to 9,652.66 bar) in order to optimally provide high strength and resistance to abrasion and fluid erosion. The outer collet support member 645 includes a first end 1620, a
10 second end 1625, a first threaded portion 1630, set screw mounting holes 1635, a recess 1640, and a second threaded portion 1645.

The first end 1620 of the outer collet support member 645 preferably includes the first threaded portion 1630 and the set screw mounting holes 1635. The first threaded portion 1630 is preferably adapted to be removably
15 coupled to the threaded portion 1370 of the second end 1360 of the liner hanger 595. The first threaded portion 1630 may include any number of conventional commercially available threaded portions. The first threaded portion 1630 is a stub acme thread available from Halliburton Energy Services in order to optimally provide high tensile strength. The set screw
20 mounting holes 1635 are preferably adapted to receive corresponding set screws 660.

The second end 1625 of the outer collet support member 645 preferably includes the recess 1640 and the second threaded portion 1645. The recess 1640 is preferably adapted to receive a portion of the end of the liner hanger
25 setting sleeve 650. In this manner, the second end 1625 of the outer collet support member 645 overlaps with a portion of the end of the liner hanger setting sleeve 650. The second threaded portion 1645 is preferably adapted to be removably coupled to the liner hanger setting sleeve 650. The second threaded portion 1645 may include any number of conventional commercially
30 available threaded portions. The second threaded portion 1645 is a stub acme

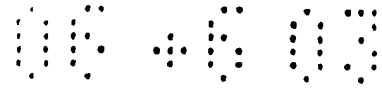

thread available from Halliburton Energy Services in order to optimally provide high tensile strength.

The liner hanger setting sleeve 650 is coupled to the outer collet support member 645. The liner hanger setting sleeve 650 is releasably
5 coupled to the collet assembly 625. The liner hanger setting sleeve 650 is movably coupled to the collet retaining adapter 640. The liner hanger setting sleeve 650 preferably has a substantially annular cross-section. The liner hanger setting sleeve 650 may be fabricated from any number of conventional commercially available materials. The liner hanger setting sleeve 650 is
10 fabricated from alloy steel having a minimum yield strength of about 75,000 to 140,000 psi (5,171.07 to 9,652.66 bar) in order to optimally provide high strength and resistance to abrasion and fluid erosion. The liner hanger setting sleeve 650 includes a first end 1650, a second end 1655, a recessed portion 1660, a plurality of collet slots 1665, a threaded portion 1670, an
15 interior shoulder 1672, and a threaded portion 1673.

The first end 1650 of the liner hanger setting sleeve 650 preferably includes the recessed portion 1660, the plurality of collet slots 1665 and the threaded portion 1670. The recessed portion 1660 of the first end 1650 of the liner hanger setting sleeve 650 is preferably adapted to mate with the
20 recessed portion 1640 of the second end 1625 of the outer collet support member 645. In this manner, the first end 1650 of the liner hanger setting sleeve 650 overlaps and mates with the second end 1625 of the outer collet support member 645. The recessed portion 1660 of the first end 1650 of the liner hanger setting sleeve 650 further includes the plurality of collet slots
25 1665. The collet slots 1665 are preferably adapted to mate with and cooperatively interact with the collet upsets 1525. The collet slots 1665 are further preferably adapted to be aligned with the collet slots 1600 of the collet retaining adapter 640. In this manner, the collet retaining adapter 640 and the liner hanger setting sleeve 650 preferably cooperatively interact with and
30 mate with the collet upsets 1525. The threaded portion 1670 is preferably adapted to be removably coupled to the second threaded portion 1645 of the

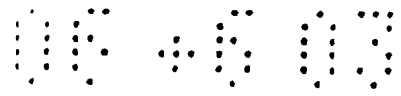

second end 1625 of the outer collet support member 645. The threaded portion 1670 may include any number of conventional threaded portions. The threaded portion 1670 is a stub acme thread available from Halliburton Energy Services in order to optimally provide high tensile strength.

5 The second end 1655 of the liner hanger setting sleeve 650 preferably includes the interior shoulder 1672 and the threaded portion 1673. The threaded portion 1673 is adapted to be coupled to conventional tubular members. In this manner tubular members are hung from the second end 1655 of the liner hanger setting sleeve 650. The threaded portion 1673 may
10 be any number of conventional commercially available threaded portions. The threaded portion 1673 is a stub acme thread available from Halliburton Energy Services in order to provide high tensile strength.

The crossover valve shear pins 655 are coupled to the second support member 515. The crossover valve shear pins 655 are releasably coupled to
15 corresponding ones of the crossover valve members 520. The crossover valve shear pins 655 may include any number of conventional commercially available shear pins. The crossover valve shear pins 655 are ASTM B16 Brass H02 condition shear pins available from Halliburton Energy Services in order to optimally provide consistency.

20 The set screws 660 coupled to the liner hanger 595 and the outer collet support member 645. The set screws 660 may include any number of conventional commercially available set screws.

The collet retaining sleeve shear pins 665 are coupled to the collet mandrel 610. The collet retaining shear pins 665 are releasably coupled to the
25 collet retaining sleeve 635. The collet retaining sleeve shear pins 665 may include any number of conventional commercially available shear pins. The collet retaining sleeve shear pins 665 are ASTM B16 Brass H02 condition shear pins available from Halliburton Energy Services in order to optimally provide consistent shear force values.

30 The first passage 670 is fluidically coupled to the second passages 675 and the secondary throat passage 695. The first passage 670 is preferably

defined by the interior of the first support member 505. The first passage 670 is preferably adapted to convey fluidic materials such as, for example, drilling mud, cement, and/or lubricants. The first passage 670 is adapted to convey fluidic materials at operating pressures and flow rates ranging from about 0 to 10,000 psi and 0 to 650 gallons/minute (0 to 689.48 bar and 0 to 2,460.52 litres/minute).

The second passages 675 are fluidically coupled to the first passage 670, the third passage 680, and the crossover valve chambers 685. The second passages 675 are preferably defined by a plurality of radial openings provided in the second end 1010 of the first support member 505. The second passages 675 are preferably adapted to convey fluidic materials such as, for example, drilling mud, cement and/or lubricants. The second passages 675 are adapted to convey fluidic materials at operating pressures and flow rates ranging from about 0 to 10,000 psi and 0 to 650 gallons/minute (0 to 689.48 bar and 0 to 2,460.52 litres/minute).

The third passage 680 is fluidically coupled to the second passages 675 and the force multiplier supply passages 790. The third passage 680 is preferably defined by the radial gap between the second end 1010 of the first support member 505 and the first end 1060 of the second support member 515. The third passage 680 is preferably adapted to convey fluidic materials such as, for example, drilling mud, cement, and/or lubricants. The third passage 680 is adapted to convey fluidic materials at operating pressures and flow rates ranging from about 0 to 10,000 psi and 0 to 200 gallons/minute (0 to 689.48 bar and 0 to 757.082368 litres/minute).

The crossover valve chambers 685 are fluidically coupled to the third passage 680, the corresponding inner crossover ports 705, the corresponding outer crossover ports 710, and the corresponding seventh passages 770. The crossover valve chambers 685 are preferably defined by axial passages provided in the second support member 515. The crossover valve chambers 685 are movably coupled to corresponding crossover valve members 520. The

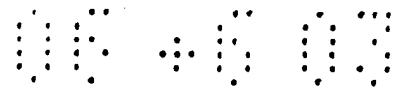

crossover valve chambers 685 preferably have a substantially constant circular cross-section.

During operation of the apparatus 500, one end of one or more of the crossover valve chambers 685 is pressurized by fluidic materials injected into the third passage 680. In this manner, the crossover valve shear pins 655 are sheared and the crossover valve members 520 are displaced. The displacement of the crossover valve members 520 causes the corresponding inner and outer crossover ports, 705 and 710, to be fluidically coupled. In a particularly preferred embodiment, the crossover valve chambers 685 are pressurized by closing the primary and/or the secondary throat passages, 690 and 695, using conventional plugs or balls, and then injecting fluidic materials into the first, second and third passages 670, 675 and 680.

The primary throat passage 690 is fluidically coupled to the secondary throat passage 695 and the fourth passage 700. The primary throat passage 690 is preferably defined by a transitional section of the interior of the second support member 515 in which the inside diameter transitions from a first inside diameter to a second, and smaller, inside diameter. The primary throat passage 690 is preferably adapted to receive and mate with a conventional ball or plug. In this manner, the first passage 670 optimally fluidically isolated from the fourth passage 700.

The secondary throat passage 695 is fluidically coupled to the first passage 670 and the primary throat passage 695. The secondary throat passage 695 is preferably defined by another transitional section of the interior of the second support member 515 in which the inside diameter transitions from a first inside diameter to a second, and smaller, inside diameter. The secondary throat passage 695 is preferably adapted to receive and mate with a conventional ball or plug. In this manner, the first passage 670 optimally fluidically isolated from the fourth passage 700.

The inside diameter of the primary throat passage 690 is less than or equal to the inside diameter of the secondary throat passage 695. In this manner, if required, a primary plug or ball can be placed in the primary

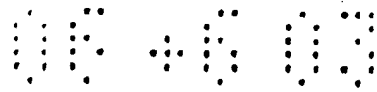

throat passage 690, and then a larger secondary plug or ball can be placed in the secondary throat passage 695. In this manner, the first passage 670 is optimally fluidically isolated from the fourth passage 700.

The fourth passage 700 is fluidically coupled to the primary throat passage 690, the seventh passage 770, the force multiplier exhaust passages 725, the collet release ports 745, and the collet release throat passage 755.

The fourth passage 700 is preferably defined by the interiors of the second support member 515, the force multiplier inner support member 530, the first coupling 545, the third support member 550, the second coupling 605, and the collet mandrel 610. The fourth passage 700 is preferably adapted to convey fluidic materials such as, for example, drilling mud, cement, and/or lubricants. The fourth passage 700 is adapted to convey fluidic materials at operating pressures and flow rates ranging from about 0 to 10,000 psi and 0 to 650 gallons/minute (0 to 689.48 bar and 0 to 2,460.52 litres/minute).

The inner crossover ports 705 are fluidically coupled to the fourth passage 700 and the corresponding crossover valve chambers 685. The inner crossover ports 705 are preferably defined by substantially radial openings provided in an interior wall of the second support member 515. The inner crossover ports 705 are preferably adapted to convey fluidic materials such as, for example, drilling mud, cement, and lubricants. The inner crossover ports 705 are adapted to convey fluidic materials at operating pressures and flow rates ranging from about 0 to 10,000 psi and 0 to 50 gallons/minute (0 to 689.48 bar and 0 to 189.27 litres/minute).

During operation of the apparatus 500, the inner crossover ports 705 are controllably fluidically coupled to the corresponding crossover valve chambers 685 and outer crossover ports 710 by displacement of the corresponding crossover valve members 520. In this manner, fluidic materials within the fourth passage 700 are exhausted to the exterior of the apparatus 500.

The outer crossover ports 710 are fluidically coupled to corresponding crossover valve chambers 685 and the exterior of the apparatus 500. The outer

crossover ports 710 are preferably defined by substantially radial openings provided in an exterior wall of the second support member 515. The outer crossover ports 710 are preferably adapted to convey fluidic materials such as, for example, drilling mud, cement, and lubricants. The outer crossover ports 5 710 are adapted to convey fluidic materials at operating pressures and flow rates ranging from about 0 to 10,000 psi and 0 to 50 gallons/minute (0 to 689.48 bar and 0 to 189.27 litres/minute).

During operation of the apparatus 500, the outer crossover ports 710 are controllably fluidically coupled to the corresponding crossover valve 10 chambers 685 and inner crossover ports 705 by displacement of the corresponding crossover valve members 520. In this manner, fluidic materials within the fourth passage 700 are exhausted to the exterior of the apparatus 500.

The force multiplier piston chamber 715 is fluidically coupled to the third 15 passage 680. The force multiplier piston chamber 715 is preferably defined by the annular region defined by the radial gap between the force multiplier inner support member 530 and the force multiplier outer support member 525 and the axial gap between the end of the second support member 515 and the end of the lubrication fitting 565.

20 During operation of the apparatus, the force multiplier piston chamber 715 is pressurized to operating pressures ranging from about 0 to 10,000 psi (0 to 689.48 bar). The pressurization of the force multiplier piston chamber 715 preferably displaces the force multiplier piston 535 and the force multiplier sleeve 540. The displacement of the force multiplier piston 535 and the force 25 multiplier sleeve 540 in turn preferably displaces the mandrel 580 and expansion cone 585. In this manner, the liner hanger 595 is radially expanded. The pressurization of the force multiplier piston chamber 715 directly displaces the mandrel 580 and the expansion cone 585. In this manner, the force multiplier piston 535 and the force multiplier sleeve 540 30 may be omitted. The lubrication fitting 565 further includes one or more slots

566 for facilitating the passage of pressurized fluids to act directly upon the mandrel 580 and expansion cone 585.

The force multiplier exhaust chamber 720 is fluidically coupled to the force multiplier exhaust passages 725. The force multiplier exhaust chamber 5 720 is preferably defined by the annular region defined by the radial gap between the force multiplier inner support member 530 and the force multiplier sleeve 540 and the axial gap between the force multiplier piston 535 and the first coupling 545. During operation of the apparatus 500, fluidic materials within the force multiplier exhaust chamber 720 are exhausted into 10 the fourth passage 700 using the force multiplier exhaust passages 725. In this manner, during operation of the apparatus 500, the pressure differential across the force multiplier piston 535 is substantially equal to the difference in operating pressures between the force multiplier piston chamber 715 and the fourth passage 700.

15 The force multiplier exhaust passages 725 are fluidically coupled to the force multiplier exhaust chamber 720 and the fourth passage 700. The force multiplier exhaust passages 725 are preferably defined by substantially radial openings provided in the second end 1160 of the force multiplier inner support member 530.

20 The second annular chamber 735 is fluidically coupled to the third annular chamber 750. The second annular chamber 735 is preferably defined by the annular region defined by the radial gap between the third support member 550 and the liner hanger 595 and the axial gap between the centralizer 590 and the collet assembly 625. During operation of the 25 apparatus 500, fluidic materials displaced by movement of the mandrel 580 and expansion cone 585 are conveyed from the second annular chamber 735 to the third annular chamber 750, the sixth passages 765, and the sixth passage 760. In this manner, the operation of the apparatus 500 is optimized.

The expansion cone travel indicator ports 740 are fluidically coupled to 30 the fourth passage 700. The expansion cone travel indicator ports 740 are controllably fluidically coupled to the second annular chamber 735. The

expansion cone travel indicator ports 740 are preferably defined by radial openings in the third support member 550. During operation of the apparatus 500, the expansion cone travel indicator ports 740 are further controllably fluidically coupled to the force multiplier piston chamber 715 by displacement of the travel port sealing sleeve 600 caused by axial displacement of the mandrel 580 and expansion cone 585. In this manner, the completion of the radial expansion process is indicated by a pressure drop caused by fluidically coupling the force multiplier piston chamber 715 with the fourth passage 700.

The collet release ports 745 are fluidically coupled to the fourth passage 700 and the collet sleeve release chamber 805. The collet release ports 745 are controllably fluidically coupled to the second and third annular chambers, 735 and 750. The collet release ports 745 are defined by radial openings in the collet mandrel 610. During operation of the apparatus 500, the collet release ports 745 are controllably pressurized by blocking the collet release throat passage 755 using a conventional ball or plug. The pressurization of the collet release throat passage 755 in turn pressurizes the collet sleeve release chamber 805. The pressure differential between the pressurized collet sleeve release chamber 805 and the third annular chamber 750 then preferably shears the collet shear pins 665 and displaces the collet retaining sleeve 635 in the axial direction.

The third annular chamber 750 is fluidically coupled to the second annular chamber 735 and the sixth passages 765. The third annular chamber 750 is controllably fluidically coupled to the collet release ports 745. The third annular chamber 750 is preferably defined by the annular region defined by the radial gap between the collet mandrel 610 and the collet assembly 625 and the first end 1585 of the collet retaining adapter and the axial gap between the collet assembly 625 and the intermediate portion 1590 of the collet retaining adapter 640.

The collet release throat passage 755 is fluidically coupled to the fourth passage 700 and the fifth passage 760. The collet release throat passage 755 is preferably defined by a transitional section of the interior of the collet

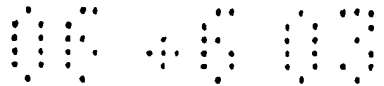

mandrel 610 including a first inside diameter that transitions into a second smaller inside diameter. The collet release throat passage 755 is preferably adapted to receive and mate with a conventional sealing plug or ball. In this manner, the fourth passage 700 is optimally fluidically isolated from the fifth
5 passage 760. The maximum inside diameter of the collet release throat passage 755 is less than or equal to the minimum inside diameters of the primary and secondary throat passages, 690 and 695.

During operation of the apparatus 500, a conventional sealing plug or ball is placed in the collet release throat passage 755. The fourth passage 700
10 and the collet release ports 745 are then pressurized. The pressurization of the collet release throat passage 755 in turn pressurizes the collet sleeve release chamber 805. The pressure differential between the pressurized collet sleeve release chamber 805 and the third annular chamber 750 then preferably shears the collet shear pins 665 and displaces the collet retaining
15 sleeve 635 in the axial direction.

The fifth passage 760 is fluidically coupled to the collet release throat passage 755 and the sixth passages 765. The fifth passage 760 is preferably defined by the interior of the second end 1595 of the collet retaining adapter 640.

20 The sixth passages 765 are fluidically coupled to the fifth passage 760 and the third annular chamber 750. The sixth passages 765 are preferably defined by approximately radial openings provided in the intermediate portion 1590 of the collet retaining adapter 640. During operation of the apparatus 500, the sixth passages 765 fluidically couple the third annular passage 750 to
25 the fifth passage 760. In this manner, fluidic materials displaced by axial movement of the mandrel 580 and expansion cone 585 are exhausted to the fifth passage 760.

The seventh passages 770 are fluidically coupled to corresponding crossover valve chambers 685 and the fourth passage 700. The seventh
30 passages 770 are preferably defined by radial openings in the intermediate portion 1065 of the second support member 515. During operation of the

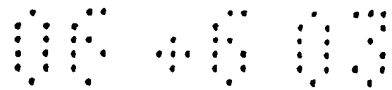

apparatus 700, the seventh passage 770 preferably maintain the rear portions of the corresponding crossover valve chamber 685 at the same operating pressure as the fourth passage 700. In this manner, the pressure differential across the crossover valve members 520 caused by blocking the primary
5 and/or the secondary throat passages, 690 and 695, is optimally maintained.

The collet sleeve passages 775 are fluidically coupled to the second annular chamber 735 and the third annular chamber 750. The collet sleeve passages 775 are preferably adapted to convey fluidic materials between the second annular chamber 735 and the third annular chamber 750. The collet
10 sleeve passages 735 are preferably defined by axial openings provided in the collet sleeve 635.

The force multiplier supply passages 790 are fluidically coupled to the third passage 680 and the force multiplier piston chamber 715. The force multiplier supply passages 790 are preferably defined by a plurality of
15 substantially axial openings in the second support member 515. During operation of the apparatus 500, the force multiplier supply passages 790 preferably convey pressurized fluidic materials from the third passage 680 to the force multiplier piston chamber 715.

The first lubrication supply passage 795 is fluidically coupled to the
20 lubrication fitting 1285 and the body of lubricant 575. The first lubrication supply passage 795 is preferably defined by openings provided in the lubrication fitting 565 and the annular region defined by the radial gap between the lubrication fitting 565 and the mandrel 580. During operation of the apparatus 500, the first lubrication passage 795 is preferably adapted to
25 convey lubricants from the lubrication fitting 1285 to the body of lubricant 575.

The second lubrication supply passage 800 is fluidically coupled to the body of lubricant 575 and the expansion cone 585. The second lubrication supply passage 800 is preferably defined by the annular region defined by the
30 radial gap between the expansion mandrel 580 and the liner hanger 595. During operation of the apparatus 500, the second lubrication passage 800 is

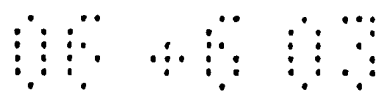

preferably adapted to convey lubricants from the body of lubricant 575 to the expansion cone 585. In this manner, the dynamic interface between the expansion cone 585 and the liner hanger 595 is optimally lubricated.

The collet sleeve release chamber 805 is fluidically coupled to the collet
5 release ports 745. The collet sleeve release chamber 805 is preferably defined by the annular region bounded by the recess 1455 and the second shoulder 1575. During operation of the apparatus 500, the collet sleeve release chamber 805 is preferably controllably pressurized. This manner, the collet release sleeve 635 is axially displaced.

10 Referring to FIGS. 4A to 4G, during operation of the apparatus 500, the apparatus 500 is coupled to an annular support member 2000 having an internal passage 2001, a first coupling 2005 having an internal passage 2010, a second coupling 2015, a third coupling 2020 having an internal passage 2025, a fourth coupling 2030 having an internal passage 2035, a tail wiper
15 2050 having an internal passage 2055, a lead wiper 2060 having an internal passage 2065, and one or more tubular members 2070. The annular support member 2000 may include any number of conventional commercially available annular support members. The annular support member 2000 further includes a conventional controllable vent passage for venting fluidic materials
20 from the internal passage 2001. In this manner, during placement of the apparatus 500 in the wellbore 2000, fluidic materials in the internal passage 2001 are vented thereby minimizing surge pressures.

The first coupling 2005 is preferably removably coupled to the second threaded portion 1615 of the collet retaining adapter 640 and the second
25 coupling 2015. The first coupling 2005 may comprise any number of conventional commercially available couplings. The first coupling 2005 is an equalizer case available from Halliburton Energy Services in order to optimally provide containment of the equalizer valve.

The second coupling 2015 is preferably removably coupled to the first
30 coupling 2005 and the third coupling 2020. The second coupling 2015 may comprise any number of conventional commercially available couplings. The

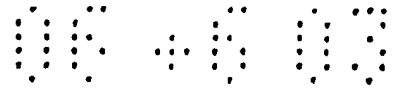

second coupling 2015 is a bearing housing available from Halliburton Energy Services in order to optimally provide containment of the bearings.

The third coupling 2020 is preferably removably coupled to the second coupling 2015 and the fourth coupling 2030. The third coupling 2020 may
5 comprise any number of conventional commercially available couplings. The third coupling 2020 is an SSR swivel mandrel available from Halliburton Energy Services in order to optimally provide for rotation of tubular members positioned above the SSR plug set.

The fourth coupling 2030 is preferably removably coupled to the third
10 coupling 2020 and the tail wiper 2050. The fourth coupling 2030 may comprise any number of conventional commercially available couplings. The fourth coupling 2030 is a lower connector available from Halliburton Energy Services in order to optimally provide a connection to a SSR plug set.

The tail wiper 2050 is preferably removably coupled to the fourth
15 coupling 2030 and the lead wiper 2060. The tail wiper 2050 may comprise any number of conventional commercially available tail wipers. The tail wiper 2050 is an SSR top plug available from Halliburton Energy Services in order to optimally provide separation of cement and drilling mud.

The lead wiper 2060 is preferably removably coupled to the tail wiper
20 2050. The lead wiper 2060 may comprise any number of conventional commercially available tail wipers. The lead wiper 2060 is an SSR bottom plug available from Halliburton Energy Services in order to optimally provide separation of mud and cement.

The first coupling 2005, the second coupling 2015, the third coupling
25 2020, the fourth coupling 2030, the tail wiper 2050, and the lead wiper 2060 are a conventional SSR wiper assembly available from Halliburton Energy Services in order to optimally provide separation of mud and cement.

The tubular member 2070 are coupled to the threaded portion 1673 of
30 the liner hanger setting sleeve 650. The tubular member 2070 may include one or more tubular members. The tubular member 2070 includes a plurality of conventional tubular members coupled end to end.

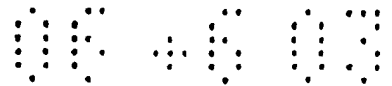

The apparatus 500 is then preferably positioned in a wellbore 2100 having a preexisting section of wellbore casing 2105 using the annular support member 2000. The wellbore 2100 and casing 2105 may be oriented in any direction from the vertical to the horizontal. The apparatus 500 is
5 positioned within the wellbore 2100 with the liner hanger 595 overlapping with at least a portion of the preexisting wellbore casing 2105. During placement of the apparatus 500 within the wellbore 2100, fluidic materials 2200 within the wellbore 2100 are conveyed through the internal passage 2065, the internal passage 2055, the internal passage 2035, the internal
10 passage 2025, the internal passage 2010, the fifth passage 760, the collet release throat passage 755, the fourth passage 700, the primary throat passage 690, the secondary throat passage 695, the first passage 670, and the internal passage 2001. In this manner, surge pressures during insertion and placement of the apparatus 500 within the wellbore 2000 are minimized. The
15 internal passage 2001 further includes a controllable venting passage for conveying fluidic materials out of the internal passage 2001.

Referring to FIGS. 5A to 5C, in the event of an emergency after placement of the apparatus 500 within the wellbore 2000, the liner hanger 595, the outer collet support member 645, and the liner hanger setting sleeve
20 650 are decoupled from the apparatus 500 by first placing a ball 2300 within the collet release throat passage 755. A quantity of a fluidic material 2305 is then injected into the fourth passage 700, the collet release ports 745, and the collet sleeve release chamber 805. The fluidic material 2305 is a non-hardenable fluidic material such as, for example, drilling mud. Continued
25 injection of the fluidic material 2305 preferably pressurizes the collet sleeve release chamber 805. The collet sleeve release chamber 805 is pressurized to operating pressures ranging from about 1,000 to 3,000 psi (68.95 to 206.84 bar) in order to optimally provide a positive indication of the shifting of the collet retaining sleeve 635 as indicated by a sudden pressure drop. The
30 pressurization of the collet sleeve release chamber 805 preferably applies an axial force to the collet retaining sleeve 635. The axial force applied to the

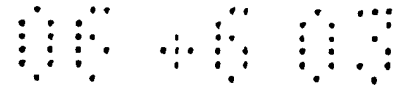

collet retaining sleeve 635 preferably shears the collet retaining sleeve shear pins 665. The collet retaining sleeve 635 then preferably is displaced in the axial direction 2310 away from the collet upsets 1525. The collet retaining sleeve 635 is axially displaced when the operating pressure within the collet sleeve release chamber 805 is greater than about 1650 psi. In this manner, the collet upsets 1525 are no longer held in place within the collet slots 1600 and 1665 by the collet retaining sleeve 635.

The collet mandrel 610 is then displaced in the axial direction 2315 causing the collet upsets 1525 to be moved in a radial direction 2320 out of the collet slots 1665. The liner hanger 595, the outer collet support member 645, and the liner hanger setting sleeve 650 are thereby decoupled from the remaining portions of the apparatus 500. The remaining portions of the apparatus 500 are then removed from the wellbore 2100. In this manner, in the event of an emergency during operation of the apparatus, the liner hanger 595, the outer collet support member 645, and the liner hanger setting sleeve 650 are decoupled from the apparatus 500. This provides an reliable and efficient method of recovering from an emergency situation such as, for example, where the liner hanger 595, and/or outer collet support member 645, and/or the liner hanger setting sleeve 650 become lodged within the wellbore 2100 and/or the wellbore casing 2105.

Referring to FIGS. 6A to 6C, after positioning the apparatus 500 within the wellbore 2100, the lead wiper 2060 is released from the apparatus 500 by injecting a conventional ball 2400 into an end portion of the lead wiper 2060 using a fluidic material 2405. The fluidic material 2405 is a non-hardenable fluidic material such as, for example, drilling mud.

Referring to FIGS. 7A to 7G, after releasing the lead wiper 2060 from the apparatus 500, a quantity of a hardenable fluidic sealing material 2500 is injected from the apparatus 500 into the wellbore 2100 using the internal passage 2001, the first passage 670, the secondary throat passage 695, the primary throat passage 690, the fourth passage 700, the collet release throat passage 755, the fifth passage 760, the internal passage 2010, the internal

passage 2025, the internal passage 2035, and the internal passage 2055. The hardenable fluidic sealing material 2500 substantially fills the annular space surrounding the liner hanger 595. The hardenable fluidic sealing material 2500 may include any number of conventional hardenable fluidic sealing materials such as, for example, cement or epoxy resin. The hardenable fluidic sealing material includes oil well cement available from Halliburton Energy Services in order to provide an optimal seal for the surrounding formations and structural support for the liner hanger 595 and tubular members 2070. In an alternative embodiment, the injection of the hardenable fluidic sealing material 2500 is omitted.

As illustrated in FIG. 7C, prior to the initiation of the radial expansion process, the preload spring 560 exerts a substantially constant axial force on the mandrel 580 and expansion cone 585. In this manner, the expansion cone 585 is maintained in a substantially stationary position prior to the initiation of the radial expansion process. The amount of axial force exerted by the preload spring 560 is varied by varying the length of the spring spacer 555. The axial force exerted by the preload spring 560 on the mandrel 580 and expansion cone 585 ranges from about 500 to 2,000 lbf (34.47 to 137.86 bar) in order to optimally provide an axial preload force on the expansion cone 585 to ensure metal to metal contact between the outside diameter of the expansion cone 585 and the interior surface of the liner hanger 595.

Referring to FIGS. 8A to 8C, after injecting the hardenable fluidic sealing material 2500 out of the apparatus 500 and into the wellbore 2100, the tail wiper 2050 is preferably released from the apparatus 500 by injecting a conventional wiper dart 2600 into the tail wiper 2050 using a fluidic material 2605. The fluidic material 2605 is a non-hardenable fluidic material such as, for example, drilling mud.

Referring to FIGS. 9A to 9H, after releasing the tail wiper 2050 from the apparatus 500, a conventional ball plug 2700 is placed in the primary throat passage 690 by injecting a fluidic material 2705 into the first passage 670. A conventional ball plug 2710 is also placed in the secondary throat

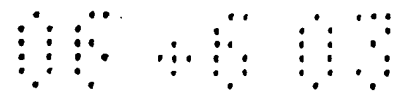

passage 695. In this manner, the first passage 670 is optimally fluidically isolated from the fourth passage 700. The differential pressure across the ball plugs 2700 and/or 2710 ranges from about 0 to 10,000 psi (0 to 689.48 bar) in order to optimally fluidically isolate the first passage 670 from the fourth
5 passage 700. The fluidic material 2705 is a non-hardenable fluidic material. The fluidic material 2705 includes one or more of the following: drilling mud, water, oil and lubricants.

The injected fluidic material 2705 preferably is conveyed to the crossover valve chamber 685 through the first passage 670, the second
10 passages 675, and the third passage 680. The injected fluidic material 2705 is also preferably conveyed to the force multiplier piston chamber 715 through the first passage 670, the second passages 675, the third passage 680, and the force multiplier supply passages 790. The fluidic material 2705 injected into the crossover valve chambers 685 preferably applies an axial force on one end
15 of the crossover valve members 520. The axial force applied to the crossover valve members 520 by the injected fluidic material 2705 shears the crossover valve shear pins 655. In this manner, one or more of the crossover valve members 520 are displaced in the axial direction thereby fluidically coupling the fourth passage 700, the inner crossover ports 705, the crossover valve
20 chambers 685, the outer crossover ports 710, and the region outside of the apparatus 500. In this manner, fluidic materials 2715 within the apparatus 500 are conveyed outside of the apparatus. The operating pressure of the fluidic material 2705 is gradually increased after the placement of the sealing ball 2700 and/or the sealing ball 2710 in the primary throat passage 690
25 and/or the secondary throat passage 695 in order to minimize stress on the apparatus 500. The operating pressure required to displace the crossover valve members 520 ranges from about 500 to 3,000 psi (34.47 to 206.84 bar) in order to optimally prevent inadvertent or premature shifting the crossover valve members 520. The one or more of the crossover valve members 520 are
30 displaced when the operating pressure of the fluidic material 2705 is greater than or equal to about 1860 psi (128.24 bar). The radial expansion of the liner

hanger 595 does not begin until one or more of the crossover valve members 520 are displaced in the axial direction. In this manner, the operation of the apparatus 500 is precisely controlled. Furthermore, the outer crossover ports 710 include controllable variable orifices in order to control the flow rate of the fluidic materials conveyed outside of the apparatus 500. In this manner, the rate of the radial expansion process is optimally controlled.

After displacing one or more of the crossover valve members 520, the operating pressure of the fluidic material 2705 is gradually increased until the radial expansion process begins. In an exemplary embodiment, the radial expansion process begins when the operating pressure of the fluidic material 2705 within the force multiplier piston chamber 715 is greater than about 3200 psi (220.64 bar). The operating pressure within the force multiplier piston chamber 715 preferably causes the force multiplier piston 535 to be displaced in the axial direction. The axial displacement of the force multiplier piston 535 preferably causes the force multiplier sleeve 540 to be displaced in the axial direction. Fluidic materials 2720 within the force multiplier exhaust chamber 720 are then preferably exhausted into the fourth passage 700 through the force multiplier exhaust passages 725. In this manner, the differential pressure across the force multiplier piston 535 is maximized. In an exemplary embodiment, the force multiplier piston 535 includes about 11.65 square inches of surface area in order to optimally increase the rate of radial expansion of the liner hanger 595 by the expansion cone 585. The operating pressure within the force multiplier piston chamber 715 ranges from about 1,000 to 10,000 psi (68.95 to 689.48 bar) during the radial expansion process in order to optimally provide radial expansion of the liner hanger 595.

The axial displacement of the force multiplier sleeve 540 causes the force multiplier sleeve 540 to drive the mandrel 580 and expansion cone 585 in the axial direction. The axial displacement of the expansion cone 585 radially expands the liner hanger 595 into contact with the preexisting wellbore casing 2105. The operating pressure within the force multiplier

000000

piston chamber 715 also drives the mandrel 580 and expansion cone 585 in the axial direction. In this manner, the axial force for axially displacing the mandrel 580 and expansion cone 585 preferably includes the axial force applied by the force multiplier sleeve 540 and the axial force applied by the
5 operating pressure within the force multiplier piston chamber 715. In an alternative preferred embodiment, the force multiplier piston 535 and the force multiplier sleeve 540 are omitted and the mandrel 580 and expansion cone 585 are driven solely by fluid pressure.

The radial expansion of the liner hanger 595 preferably causes the top
10 rings 1385 and the lower rings 1390 of the liner hanger 595 to penetrate the interior walls of the preexisting wellbore casing 2105. In this manner, the liner hanger 595 is optimally coupled to the wellbore casing 2105. During the radial expansion of the liner hanger 595, the intermediate sealing members 1395 of the liner hanger 595 fluidically seal the interface between the radially
15 expanded liner hanger 595 and the interior surface of the wellbore casing 2105.

During the radial expansion process, the dynamic interface between the exterior surface of the expansion cone 585 and the interior surface of the liner hanger 595 is preferably lubricated by lubricants supplied from the body of
20 lubricant 575 through the second lubrication supply passage 800. In this manner, the operational efficiency of the apparatus 500 during the radial expansion process is optimized. The lubricants supplied by the body of lubricant 575 through the second lubrication passage 800 are injected into the dynamic interface between the exterior surface of the expansion cone 585 and
25 the interior surface of the liner hanger 595 substantially as disclosed in one or more of the following: (1) U.S. Patent Application Serial No. 09/440,338, attorney docket number 25791.9.02, filed on 11/15/98, which claimed benefit of the filing date of U.S. Provisional Patent Application Serial Number 60/108,558, attorney docket number 25791.9, filed on 11/16/1998, (2) U.S.
30 Patent Application Serial No.09/454,139, attorney docket number 25791.3.02, filed on 12/3/99, which claimed benefit of the filing date of U.S. Provisional

00 40 00

Patent Application Serial Number 60/111,293, filed on 12/7/1998, (3) U.S. Patent Application Serial Number 09/502,350, attorney docket number 25791.8.02, filed on 2/10/00, which claimed the benefit of the filing date of U.S. Provisional Patent Application Serial Number 60/119,611, attorney
5 docket number 25791.8, filed 2/11/1999, (4) U.S. Patent Application Serial Number 09/510,913, attorney docket number 25791.7.02, filed on 2/23/00, which claimed the benefit of the filing date of U.S. Provisional Patent Application Serial Number 60/121,702, attorney docket number 25791.7, filed on 2/25/1999, (5) U.S. Patent Application Serial Number 09/511,941, attorney
10 docket number 25791.16.02, filed on 2/24/00, which claimed the benefit of the filing date of U.S. Provisional Patent Application number 60/121,907, attorney docket number 25791.16, filed 2/26/1999, (6) U.S. Provisional Patent Application Serial Number 60/124,042, attorney docket number 25791.11, filed on 3/11/1999, (7) U.S. Provisional Patent Application Serial Number
15 60/131,106, attorney docket number 25791.23, filed on 4/26/1999, (8) U.S. Provisional Patent Application Serial Number 60/137,998, attorney docket number 25791.17, filed on 6/7/1999, (9) U.S. Provisional Patent Application Serial Number 60/143,039, attorney docket number 25791.26, filed on 7/9/1999, and (10) U.S. Provisional Patent Application Serial Number
20 60/146,203, attorney docket number 25791.25, filed on 7/29/1999, the disclosures of which are incorporated by reference.

The expansion cone 585 is reversible. In this manner, if one end of the expansion cone 585 becomes excessively worn, the apparatus 500 can be disassembled and the expansion cone 585 reversed in order to use the un-worn
25 end of the expansion cone 585 to radially expand the liner hanger 595. The expansion cone 585 further includes one or more surface inserts fabricated from materials such as, for example, tungsten carbide, in order to provide an extremely durable material for contacting the interior surface of the liner hanger 595 during the radial expansion process.

30 During the radial expansion process, the centralizer 590 preferably centrally positions the mandrel 580 and the expansion cone 585 within the

0000000000

interior of the liner hanger 595. In this manner, the radial expansion process is optimally provided.

During the radial expansion process, fluidic materials 2725 within the second annular chamber 735 are preferably conveyed to the fifth passage 760 through the collet sleeve passages 775, the flow passages 1530, the third annular chamber 750, and the sixth passages 765. In this manner, the axial displacement of the mandrel 580 and the expansion cone 585 are optimized.

Referring to FIGS. 10A to 10E, the radial expansion of the liner hanger 595 is stopped by fluidically coupling the force multiplier piston chamber 715 with the fourth passage 700. In particular, during the radial expansion process, the continued axial displacement of the mandrel 580 and the expansion cone 585, caused by the injection of the fluidic material 2705, displaces the travel port sealing sleeve 600 and causes the force multiplier piston chamber 715 to be fluidically coupled to the fourth passage 700 through the expansion cone travel indicator ports 740. The travel port sealing sleeve 600 is removably coupled to the third support member 550 by one or more shear pins. In this manner, accidental movement of the travel port sealing sleeve 600 is prevented.

The fluidic coupling of the force multiplier piston chamber 715 with the fourth passage 700 reduces the operating pressure within the force multiplier piston chamber 715. The reduction in the operating pressure within the force multiplier piston chamber 715 stops the axial displacement of the mandrel 580 and the expansion cone 585. In this manner, the radial expansion of the liner hanger 595 is optimally stopped. In an alternative preferred embodiment, the drop in the operating pressure within the force multiplier piston chamber 715 is remotely detected and the injection of the fluidic material 2705 is reduced and/or stopped in order to gradually reduce and/or stop the radial expansion process. In this manner, the radial expansion process is optimally controlled by sensing the operating pressure within the force multiplier piston chamber 715.

After the completion of the radial expansion process, the hardenable fluidic sealing material 2500 is cured. In this manner, a hard annular outer layer of sealing material is formed in the annular region around the liner hanger 595. In an alternative embodiment, the hardenable fluidic sealing material 2500 is omitted.

Referring to FIGS. 11A to 11E, the liner hanger 595, the outer collet support member 645, and the liner hanger setting sleeve 650 are then decoupled from the apparatus 500. The liner hanger 595, the collet retaining adapter 640, the outer collet support member 645, and the liner hanger setting sleeve 650 are decoupled from the apparatus 500 by first displacing the annular support member 2000, the first support member 505, the second support member 515, the force multiplier outer support member 525, the force multiplier inner support member 530, the first coupling 545, the third support member 550, the second coupling 605, the collet mandrel 610, and the collet retaining adapter 640 in the axial direction 2800 relative to the liner hanger 595, the outer collet support member 645, and the liner hanger setting sleeve 650.

In particular, as illustrated in FIG. 11D, the axial displacement of the collet mandrel 610 in the axial direction 2800 preferably displaces the collet retaining sleeve 635 in the axial direction 2800 relative to the collet upsets 1525. In this manner, the collet upsets 1525 are no longer held in the collet slots 1665 by the collet retaining sleeve 635. Furthermore, the axial displacement of the collet mandrel 610 in the axial direction 2800 preferably displaces the first shoulder 1445 in the axial direction 2800 relative to the locking dogs 620. In this manner, the locking dogs 620 lock onto the first shoulder 1445 when the collet mandrel 610 is then displaced in the axial direction 2805. Axial displacement of the collet mandrel of about 1.50 inches displaces the collet retaining sleeve 635 out from under the collet upsets 1525 and also locks the locking dogs 620 onto the first shoulder 1445 of the collet mandrel 610. Furthermore, the axial displacement of the collet retaining

adapter 640 in the axial direction 2800 also preferably displaces the slots 1600 away from the collet upsets 1525.

The liner hanger 595, the collet retaining adapter 640, the outer collet support member 645, and the liner hanger setting sleeve 650 are then
5 decoupled from the apparatus 500 by displacing the annular support member 2000, the first support member 505, the second support member 515, the force multiplier outer support member 525, the force multiplier inner support member 530, the first coupling 545, the third support member 550, the second coupling 605, the collet mandrel 610, and the collet retaining adapter 640 in
10 the axial direction 2805 relative to the liner hanger 595, the outer collet support member 645, and the liner hanger setting sleeve 650. In particular, the subsequent axial displacement of the collet mandrel 610 in the axial direction 2805 preferably pulls and decouples the collet upsets 1525 from the collet slots 1665. The angled outer surfaces 1545 of the collet upsets 1525
15 facilitate the decoupling process.

In an alternative embodiment, if the locking dogs 620 do not lock onto the first shoulder 1445 of the collet mandrel 610, then the annular support member 2000, the first support member 505, the second support member 515, the force multiplier outer support member 525, the force multiplier inner
20 support member 530, the first coupling 545, the third support member 550, the second coupling 605, the collet mandrel 610, and the collet retaining adapter 640 are then displaced back in the axial direction 2800 and rotated. The rotation of the annular support member 2000, the first support member 505, the second support member 515, the force multiplier outer support
25 member 525, the force multiplier inner support member 530, the first coupling 545, the third support member 550, the second coupling 605, the collet mandrel 610, and the collet retaining adapter 640 preferably misaligns the collet slots 1600 and 1665. In this manner, a subsequent displacement of the
in the axial direction 2805 pushes the collet upsets 1525 out of the collet slots
30 1665 in the liner hanger setting sleeve 650. The amount of rotation ranges from about 5 to 40 degrees. In this manner, the liner hanger 595, the outer

collet support member 645, and the liner hanger setting sleeve 650 are then decoupled from the apparatus 500.

The removal of the apparatus 500 from the interior of the radially expanded liner hanger 595 is facilitated by the presence of the body of lubricant 575. In particular, the body of lubricant 575 preferably lubricates the interface between the interior surface of the radially expanded liner hanger 595 and the exterior surface of the expansion cone 585. In this manner, the axial force required to remove the apparatus 500 from the interior of the radially expanded liner hanger 595 is minimized.

10 Referring to FIGS. 12A to 12C, after the removal of the remaining portions of the apparatus 500, a new section of wellbore casing is provided that preferably includes the liner hanger 595, the outer collet support member 645, the liner hanger setting sleeve 650, the tubular members 2070 and an outer annular layer of cured material 2900.

15 The interior of the radially expanded liner hanger 595 may be used as a polished bore receptacle ("PBR"). Alternatively, interior of the radially expanded liner hanger 595 may be machined and then used as a PBR. Alternatively, the first end 1350 of the liner hanger 595 may be threaded and coupled to a PBR.

20 All surfaces of the apparatus 500 that provide a dynamic seal are nickel plated in order to provide optimal wear resistance.

Referring to FIGS. 13A to 13G, an alternative embodiment of an apparatus 3000 for forming or repairing a wellbore casing, pipeline or structural support will be described. The apparatus 3000 preferably includes
25 the first support member 505, the debris shield 510, the second support member 515, the one or more crossover valve members 520, the force multiplier outer support member 525, the force multiplier inner support member 530, the force multiplier piston 535, the force multiplier sleeve 540, the first coupling 545, the third support member 550, the spring spacer 555,
30 the preload spring 560, the lubrication fitting 565, the lubrication packer sleeve 570, the body of lubricant 575, the mandrel 580, the expansion cone

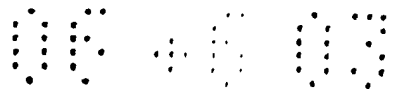

585, the centralizer 590, the liner hanger 595, the travel port sealing sleeve 600, the second coupling 605, the collet mandrel 610, the load transfer sleeve 615, the one or more locking dogs 620, the locking dog retainer 622, the collet assembly 625, the collet retaining sleeve 635, the collet retaining adapter 640, 5 the outer collet support member 645, the liner hanger setting sleeve 650, the one or more crossover valve shear pins 655, the one or more collet retaining sleeve shear pins 665, the first passage 670, the one or more second passages 675, the third passage 680, the one or more crossover valve chambers 685, the primary throat passage 690, the secondary throat passage 695, the fourth 10 passage 700, the one or more inner crossover ports 705, the one or more outer crossover ports 710, the force multiplier piston chamber 715, the force multiplier exhaust chamber 720, the one or more force multiplier exhaust passages 725, the second annular chamber 735, the one or more expansion cone travel indicator ports 740, the one or more collet release ports 745, the 15 third annular chamber 750, the collet release throat passage 755, the fifth passage 760, the one or more sixth passages 765, the one or more seventh passages 770, the one or more collet sleeve passages 775, the one or more force multiplier supply passages 790, the first lubrication supply passage 795, the second lubrication supply passage 800, the collet sleeve release chamber 805, 20 and a standoff adaptor 3005.

Except as described below, the design and operation of the first support member 505, the debris shield 510, the second support member 515, the one or more crossover valve members 520, the force multiplier outer support member 525, the force multiplier inner support member 530, the force multiplier 25 piston 535, the force multiplier sleeve 540, the first coupling 545, the third support member 550, the spring spacer 555, the preload spring 560, the lubrication fitting 565, the lubrication packer sleeve 570, the body of lubricant 575, the mandrel 580, the expansion cone 585, the centralizer 590, the liner hanger 595, the travel port sealing sleeve 600, the second coupling 605, the 30 collet mandrel 610, the load transfer sleeve 615, the one or more locking dogs 620, the locking dog retainer 622, the collet assembly 625, the collet retaining

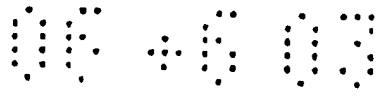

sleeve 635, the collet retaining adapter 640, the outer collet support member 645, the liner hanger setting sleeve 650, the one or more crossover valve shear pins 655, the one or more collet retaining sleeve shear pins 665, the first passage 670, the one or more second passages 675, the third passage 680, the
5 one or more crossover valve chambers 685, the primary throat passage 690, the secondary throat passage 695, the fourth passage 700, the one or more inner crossover ports 705, the one or more outer crossover ports 710, the force multiplier piston chamber 715, the force multiplier exhaust chamber 720, the one or more force multiplier exhaust passages 725, the second annular
10 chamber 735, the one or more expansion cone travel indicator ports 740, the one or more collet release ports 745, the third annular chamber 750, the collet release throat passage 755, the fifth passage 760, the one or more sixth passages 765, the one or more seventh passages 770, the one or more collet sleeve passages 775, the one or more force multiplier supply passages 790, the
15 first lubrication supply passage 795, the second lubrication supply passage 800, and the collet sleeve release chamber 805 of the apparatus 3000 are preferably provided as described above with reference to the apparatus 500 in FIGS. 2A to 12C.

Referring to FIGS. 13A to 13C, the standoff adaptor 3005 is coupled to
20 the first end 1005 of the first support member 505. The standoff adaptor 3005 preferably has a substantially annular cross-section. The standoff adaptor 3005 may be fabricated from any number of conventional commercially available materials. Preferably, the standoff adaptor 3005 is fabricated from alloy steel having a minimum yield strength of about 75,000 to 140,000 psi
25 (5,171.07 to 9,652.66 bar) in order to optimally provide high tensile strength and resistance to abrasion and fluid erosion. Preferably, the standoff adaptor 3005 includes a first end 3010, a second end 3015, an intermediate portion 3020, a first threaded portion 3025, one or more slots 3030, and a second threaded portion 3035.

30 The first end 3010 of the standoff adaptor 3005 preferably includes the first threaded portion 3025. The first threaded portion 3025 is preferably

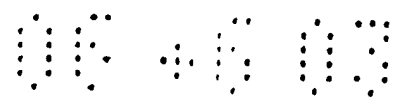

adapted to be removably coupled to a conventional tubular support member. The first threaded portion 3025 may be any number of conventional threaded portions. Preferably, the first threaded portion 3025 is a 4½" (11.43 centimetres)" API IF JT BOX thread in order to optimally provide tensile strength.

The intermediate portion 3020 of the standoff adaptor 3005 preferably includes the slots 3030. The outside diameter of the intermediate portion 3020 of the standoff adaptor 3005 is preferably greater than the outside diameter of the liner hanger 595 in order to optimally protect the sealing members 1395, and the top and bottom rings, 1380 and 1390, from abrasion when positioning and/or rotating the apparatus 3000 within a wellbore, or other tubular member. The intermediate portion 3020 of the standoff adaptor 3005 preferably includes a plurality of axial slots 3030 equally positioned about the circumference of the intermediate portion 3020 in order to optimally permit wellbore fluids and other materials to be conveyed along the outside surface of the apparatus 3000.

The second end of the standoff adaptor 3005 preferably includes the second threaded portion 3035. The second threaded portion 3035 is preferably adapted to be removably coupled to the first threaded portion 1015 of the first end 1005 of the first support member 505. The second threaded portion 3035 may be any number of conventional threaded portions. Preferably, the second threaded portion 3035 is a 4½" (11.43 centimetres)" API IF JT PIN thread in order to optimally provide tensile strength.

Referring to FIGS. 13D and 13E, in the apparatus 3000, the second end 1360 of the liner hanger 595 is preferably coupled to the first end 1620 of the outer collet support member 645 using a threaded connection 3040. The threaded connection 3040 is preferably adapted to provide a threaded connection having a primary metal-to-metal seal 3045a and a secondary metal-to-metal seal 3045b in order to optimally provide a fluidic seal. Preferably, the threaded connection 3040 is a DS HST threaded connection

available from Halliburton Energy Services in order to optimally provide high tensile strength and a fluidic seal for high operating temperatures.

Referring to FIGS. 13D and 13F, in the apparatus 3000, the second end 1625 of the outer collet support member 645 is preferably coupled to the first 5 end 1650 of the liner hanger setting sleeve 650 using a substantially permanent connection 3050. In this manner, the tensile strength of the connection between the second end 1625 of the outer collet support member 645 and the first end 1650 of the liner hanger setting sleeve 650 is optimized. Preferably, the permanent connection 3050 includes a threaded connection 10 3055 and a welded connection 3060. In this manner, the tensile strength of the connection between the second end 1625 of the outer collet support member 645 and the first end 1650 of the liner hanger setting sleeve 650 is optimized.

Referring to FIGS. 13D, 13E and 13F, in the apparatus 3000, the liner 15 hanger setting sleeve 650 further preferably includes an intermediate portion 3065 having one or more axial slots 3070. Preferably, the outside diameter of the intermediate portion 3065 of the liner hanger setting sleeve 650 is greater than the outside diameter of the liner hanger 595 in order to protect the sealing elements 1395 and the top and bottom rings, 1385 and 1390, from 20 abrasion when positioning and/or rotating the apparatus 3000 within a wellbore casing or other tubular member. The intermediate portion 3065 of the liner hanger setting sleeve 650 preferably includes a plurality of axial slots 3070 equally positioned about the circumference of the intermediate portion 3065 in order to optimally permit wellbore fluids and other materials 25 to be conveyed along the outside surface of the apparatus 3000.

In several alternative preferred embodiments, the apparatus 500 and 3000 are used to fabricate and/or repair a wellbore casing, a pipeline, or a structural support. In several other alternative embodiments, the apparatus 500 and 3000 are used to fabricate a wellbore casing, pipeline, or structural 30 support including a plurality of concentric tubular members coupled to a preexisting tubular member.

Claims

1. An apparatus for coupling a tubular member to a preexisting structure, comprising:
 - 5 a first support member defining a first fluid passage;
 - a manifold coupled to the first support member defining:
 - a second fluid passage coupled to the first fluid passage including a throat passage adapted to receive a plug;
 - a third fluid passage coupled to the second fluid passage; and
 - 10 a fourth fluid passage coupled to the second fluid passage;
 - a second support member coupled to the manifold defining a fifth fluid passage coupled to the second fluid passage;
 - an expansion cone coupled to the second support member;
 - a tubular member coupled to the first support member;
 - 15 a first interior chamber defined by the portion of the tubular member above the manifold, the first interior chamber coupled to the fourth fluid passage;
 - a second interior chamber defined by the portion of the tubular member between the manifold and the expansion cone, the second interior chamber
 - 20 coupled to the third fluid passage;
 - a third interior chamber defined by the portion of the tubular member below the expansion cone, the third interior chamber coupled to the fifth fluid passage; and
 - a shoe coupled to the tubular member defining:
 - 25 a throat passage coupled to the third interior chamber adapted to receive a wiper dart; and a sixth fluid passage coupled to the throat passage.

2. The apparatus of claim 1, wherein the manifold is positioned above the expansion cone.

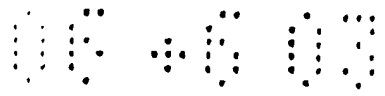

3. The apparatus of claim 1, wherein the manifold is spaced apart from the expansion cone.
4. The apparatus of claim 1, wherein the first interior chamber comprises an annular chamber.
- 5 5. The apparatus of claim 1, wherein the second interior chamber comprises an annular chamber.
6. The apparatus of claim 1, wherein the third interior chamber comprises an annular chamber.
7. The apparatus of claim 1, wherein the expansion cone is movably
10 coupled to the second support member.
8. The apparatus of claim 1, wherein the first support member further defines a pressure relief passage.
9. The apparatus of claim 1, wherein the third fluid passage is coupled to the second fluid passage upstream from the throat passage defined by the
15 manifold.
10. The apparatus of claim 1, wherein the fourth fluid passage is coupled to the second fluid passage downstream from the throat passage defined by the manifold.
11. The apparatus of claim 1, wherein the third fluid passage is coupled to
20 the second fluid passage upstream from the throat passage defined by the manifold; and wherein the fourth fluid passage is coupled to the second fluid passage downstream from the throat passage defined by the manifold.

12. The apparatus of claim 1, wherein the tubular member comprises:
an upper tubular portion having a first inside diameter; and
a lower tubular portion having a second inside diameter;
wherein the first inside diameter is greater than the second inside diameter.
- 5 13. The apparatus of claim 12, wherein the manifold is positioned within
the upper tubular portion of the tubular member.
14. The apparatus of claim 13, further comprising one or more sealing
members coupled to the manifold for fluidicly sealing the interface between
the manifold and the upper tubular portion of the tubular member.
- 10 15. The apparatus of claim 12, wherein a portion of the expansion cone is
positioned within the upper tubular portion of the tubular member; and
wherein another portion of the expansion cone is positioned within the lower
tubular portion of the tubular member.
- 15 16. The apparatus of claim 15, further comprising one or more sealing
members coupled to the other portion of the expansion cone for fluidicly
sealing the interface between the expansion cone and the lower tubular
portion of the tubular member.
17. The apparatus of claim 1, wherein the first interior chamber is fluidicly
isolated from the second interior chamber.
- 20 18. The apparatus of claim 1, wherein the second interior chamber is
fluidicly isolated from the third interior chamber.
19. The apparatus of claim 1, wherein the third interior chamber is
fluidicly isolated from the first interior chamber.

20. The apparatus of claim 1, further comprising one or more sealing members coupled to the expansion cone for fluidically sealing the interface between the expansion cone and the tubular member.

21. The apparatus of claim 1, further comprising one or more sealing
5 members coupled to the manifold for fluidically sealing the interface between the manifold and the tubular member.

22. An apparatus for coupling a tubular member to a preexisting structure, comprising:

- 10 a first support member defining a first fluid passage and a pressure relief passage controllably coupled to the first fluid passage;
- a manifold coupled to the first support member defining:
 - a second fluid passage coupled to the first fluid passage including a throat passage adapted to receive a plug;
 - a third fluid passage coupled to the second fluid passage; and
 - 15 a fourth fluid passage coupled to the second fluid passage;
 wherein the third fluid passage is coupled to the second fluid passage upstream from the throat passage; and wherein the fourth fluid passage is coupled to the second fluid passage downstream from the throat passage;
- 20 a second support member coupled to the manifold defining a fifth fluid passage coupled to the second fluid passage;
- an expansion cone movably coupled to the second support member below and spaced apart from the manifold;
- a tubular member coupled to the first support member, comprising:
 - an upper tubular portion having a first inside diameter; and
 - 25 a lower tubular portion having a second inside diameter;
 wherein the first inside diameter is greater than the second inside diameter;

one or more first sealing members coupled to the manifold for fluidically sealing the interface between the manifold and the upper tubular portion of the tubular member;

one or more second sealing members coupled to the expansion cone for
5 fluidically sealing the interface between the expansion cone and the lower tubular portion of the tubular member;

a first interior annular chamber defined by the portion of the tubular member above the manifold, the first interior chamber coupled to the fourth fluid passage;

10 a second interior annular chamber defined by the portion of the tubular member between the manifold and the expansion cone, the second interior chamber coupled to the third fluid passage;

a third interior annular chamber defined by the portion of the tubular member below the expansion cone, the third interior chamber coupled to the

15 fifth fluid passage; and

a shoe coupled to the tubular member defining:

a throat passage coupled to the third interior chamber adapted to receive a wiper dart; and

a sixth fluid passage coupled to the throat passage;

20 wherein the first interior chamber is fluidically isolated from the second interior chamber;

wherein the second interior chamber is fluidically isolated from the third interior chamber; and

25 wherein the third interior chamber is fluidically isolated from the first interior chamber.

23. An apparatus for coupling a tubular member to a preexisting structure substantially as described herein, with reference to and as shown in the accompanying drawings.